



13SEER&14SEER Rooftop Package Units



13/14SEER R410A
Horizontal / Downflow Discharged



13SEER R410A
Horizontal Discharged

Features

- Wide-capacity range in both cooling only and heat pump models.
- High-efficiency 13 and 14 SEER ratings.
- Architecturally compatible, anti-rust steel cabinets. 1,000-hour salt spray tested.
- Removable bottom for side- or bottom return applications.
- High-efficiency compressors operate smoothly, quietly, consistently.
- Internal safeguards protect compressor against high pressure, low pressure, coil temperature and power surge.(heat pump only).
- Reliable thermostatic operation, with either Midea or many other brand-name controller..
- Auxiliary electric heaters (5kW,7.5kW, 10kW, 15kW, 20kW, 25kW) .

AHRI Certified and ETL Listed.



Single Phase 14SEER Horizontal/Downflow Discharged

Sale Model			MRB-48CWN1-M14	MRB-48HWN1-M14	MRB-60CWN1-M14	MRB-60HWN1-M14
Power supply		V-Ph-Hz	208/230V-1Ph-60HZ	208/230V-1Ph-60HZ	208/230-1Ph-60Hz	208/230-1Ph-60Hz
Cooling	Capacity	Btu/h	48000	48000	59500	60000
	SEER		14	14	14	14
Heating	Capacity	Btu/h	/	48000	/	60000
	HSPF		/	8	/	8
MCA		A	32.6	32.6	38.7	38.7
MOP		A	50	50	60	60
Compressor	Type		Scroll	Scroll	Scroll	Scroll
	Rated current(RLA)	A	21.8	21.8	26.4	26.4
	Locked rotor Amp(LRA)	A	117	117	134	134
Indoor fan motor	Model		YDK400-6E	YDK400-6E	YDK600-6E	YDK600-6E
	Type		PSC	PSC	PSC	PSC
	Output	HP	3/4	3/4	1	1
	Capacitor	uF	20	20	20	20
	RPM		1075	1075	1075	1075
Side supply /Side return duct dimensions(W*D)		inch	14-1/2x14-1/2	14-1/2x14-1/2	14-1/2x14-1/2	14-1/2x14-1/2
Bottom supply /Bottom return duct dimensions(W*D)		inch	15x15	15x15	15x15	15x15
Outdoor fan motor	Model		YDK230-6G-1	YDK230-6G-1	YDK230-6G-1	YDK230-6G-1
	Type		PSC	PSC	PSC	PSC
	Output	HP	1/3	1/3	1/3	1/3
	Capacitor	uF	15	15	15	15
	RPM		1075	1075	1075	1075
Outdoor sound level(sound pressure level)		dB(A)	65	62	64	63
Outdoor unit	Dimension(WXHXD)	mm	1920×840×1068	1920×840×1068	1920×840×1068	1920×840×1068
	Packing(WXHXD)	inch	75-5/8×33×42	75-5/8×33×42	75-5/8×33×42	75-5/8×33×42
	Net/Gross weight	Lbs.	496/505	505/514	507/516	516/525
Shipping (40HQ)			36	36	36	36

Three Phase 13SEER Horizontal/Downflow Discharged

Sale Model			MRB-36CWN1-X13	MRB-36HWN1-X13	MRB-48CWN1-X13	MRB-48HWN1-X13	MRB-60CWN1-X13	MRB-60HWN1-X13
Power supply		V-Ph-Hz	208/230V-3Ph-60Hz	208/230V-3Ph-60Hz	208/230V-3Ph-60Hz	208/230V-3Ph-60Hz	208/230V-3Ph-60Hz	208/230V-3Ph-60Hz
Cooling	Capacity	Btu/h	36000	34400	47000	45500	57500	57500
	SEER		13	13	13	13	13	13
Heating	Capacity	Btu/h	/	36000	/	48000	/	59500
	HSPF		/	7.7	/	7.7	/	7.7
MCA		A	16.6	16.6	22.5	22.5	25.7	25.7
MOP		A	25	25	35	35	40	40
Compressoer	Type		Scroll	Scroll	Scroll	Scroll	Scroll	Scroll
	Rated current(RLA)	A	10.4	10.4	13.7	13.7	16	16
	Locked rotor Amp(LRA)	A	73	73	83.1	83.1	110	110
Indoor fan motor	Model		YDK270-6E	YDK270-6E	YDK400-6E	YDK400-6E	YDK600-6E	YDK600-6E
	Type		PSC	PSC	PSC	PSC	PSC	PSC
	Output	HP	1/2	1/2	3/4	3/4	1	1
	Capacitor	uF	10	10	20	20	20	20
	RPM		1075	1075	1075	1075	1075	1075
Side supply /Side return duct dimensions(W*D)		inch	14-1/2x14-1/2	14-1/2x14-1/2	14-1/2x14-1/2	14-1/2x14-1/2	14-1/2x14-1/2	14-1/2x14-1/2
Bottom supply /Bottom return duct dimensions(W*D)		inch	15x15	15x15	15x15	15x15	15x15	15x15
Outdoor fan motor	Model		YDK110-8G-1	YDK110-8G-1	YDK230-6G-1	YDK230-6G-1	YDK230-6G-1	YDK230-6G-1
	Type		PSC	PSC	PSC	PSC	PSC	PSC
	Output	HP	1/6	1/6	1/3	1/3	1/3	1/3
	Capacitor	uF	6	6	15	15	15	15
	RPM		825	825	1075	1075	1075	1075
Outdoor sound level(sound pressure level)		dB(A)	60.8	60.8	63	63.1	64.3	64
Outdoor unit	Dimension(WXHXD)	mm	1920×714×1068	1920×714×1068	1920×840×1068	1920×840×1068	1920×840×1068	1920×840×1068
	Packing(WXHXD)	inch	75-5/8×28-1/8×42	75-5/8×28-1/8×42	75-5/8×33×42	75-5/8×33×42	75-5/8×33×42	75-5/8×33×42
	Net/Gross weight	Lbs.	432/441	441/450	496/505	505/514	507/516	516/525
Shipping (40HQ)			36	36	36	36	36	36

6/10/11
M.R.B. 36/13



INSTALLATION INSTRUCTIONS

PACKAGE HEAT PUMP & AIR CONDITIONING

FEATURING R-410A

13 SEER SERIES - (2-5Tons)

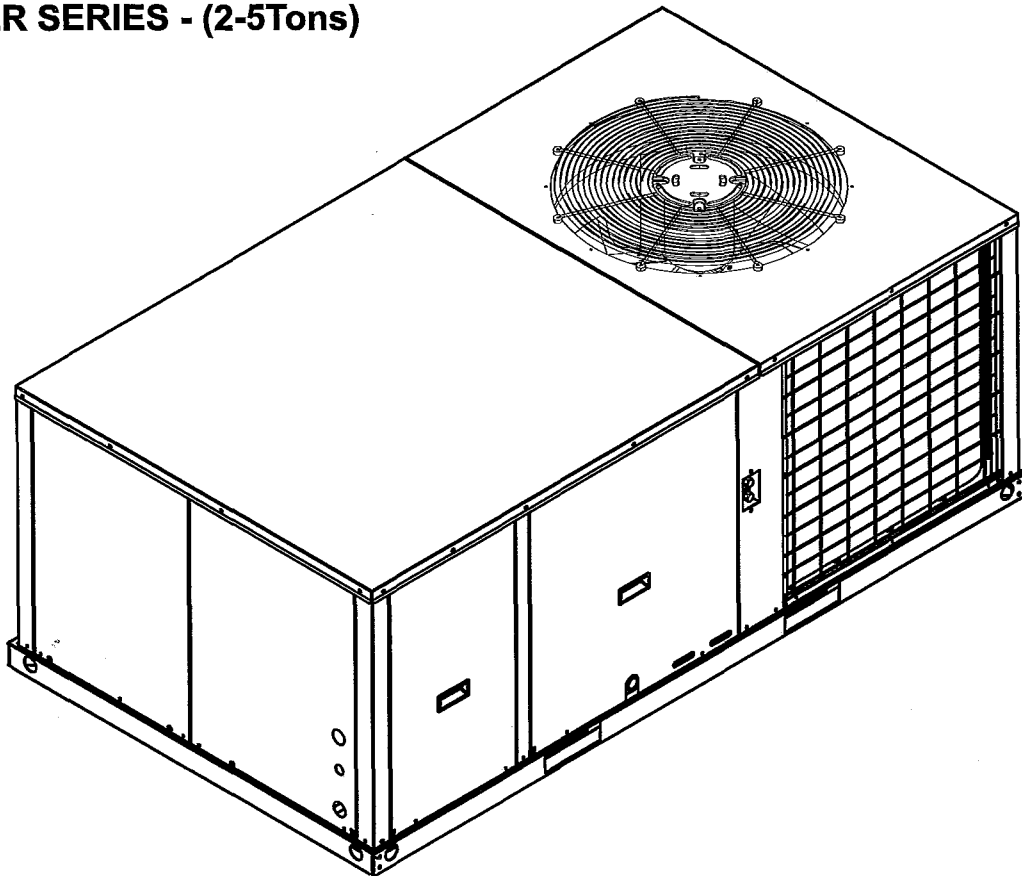

 **RECOGNIZE THIS SYMBOL AS AN INDICATION OF IMPORTANT SAFETY INFORMATION**

 **WARNING**

These instructions are intended as an aid to qualified licensed service personnel for proper installation, adjustment and operation of this unit. Read these instructions thoroughly before attempting installation or operation. Failure to follow these instructions may result in improper installation, adjustment, service or maintenance possibly resulting in fire, electrical shock, property damage, personal injury or death.



DO NOT DESTROY THIS MANUAL
Please read carefully and keep in a safe place for future reference by a serviceman.

TABLE OF CONTENTS

1.0 SAFETY.....	3
1.1 INSPECTION.....	4
1.2 LIMITATIONS.....	4
2.0 INSTALLATION.....	4
2.1 PRE-INSTALLATION.....	4
2.2 CLEARANCE.....	5
2.3 RIGGING AND HANDING.....	5
2.4 ROOF CURB.....	8
3.0 DUCTWORK.....	10
4.0 CONDENSATE DRAIN CONNECTION.....	10
4.1 INSTALL DRAIN PIPE.....	10
4.2 REMOVAL AND CLEANING THE DRAIN PAN.....	11
5.0 FILTERS.....	11
6.0 ELECTRICAL WIRING.....	11
6.1 POWER WIRING.....	12
6.2 GROUNDING.....	12
6.3 CONTROL WIRING.....	12
7.0 AIRFLOW PERFORMANCE.....	19
7.1 AIRFLOW PERFORMANCE DATA.....	19
8.0 SYSTEM OPERATION.....	31
8.1 COMPRESSOR CRANKCASE HEATER.....	31
8.2 OPERATION.....	31
8.3 DEFROST MODE.....	32
8.4 MANUAL DEFROST MODE.....	32
8.5 THERMOSTAT SIGNALS.....	32
9.0 OPERATION CHECK-UP.....	34
10.0 TROUBLE SHOOTING.....	34

LIST OF TABLES

TABLE 2-1 UNIT CLEARANCE.....	6
TABLE 6-1 13 SEER HEAT PUMP W/WITHOUT ELECTRIC HEAT.....	14
TABLE 6-2 13 SEER COOLING ONLY W/WITHOUT ELECTRIC HEAT.....	15
TABLE 6-3 13 SEER PHYSICAL DATA.....	16
TABLE 7-1 SIDE DUCT APPLICATION.....	19
TABLE 7-2 BOTTOM DUCT APPLICATION.....	20
TABLE 7-3 REFRIGERANT CHARGE FOR A/C SYSTEM.....	22
TABLE 7-4 & 7-5 REFRIGERANT CHARGE FOR H/P SYSTEM.....	22
TABLE 7-6 REFRIGERANT CHARGE FOR A/C SYSTEM.....	23
TABLE 7-7 & 7-8 REFRIGERANT CHARGE FOR A/C SYSTEM.....	23
TABLE 7-9 REFRIGERANT CHARGE FOR A/C SYSTEM.....	24
TABLE 7-10 & 7-11 REFRIGERANT CHARGE FOR H/P SYSTEM.....	24
TABLE 7-12 REFRIGERANT CHARGE FOR A/C SYSTEM.....	25
TABLE 7-13 & 7-14 REFRIGERANT CHARGE FOR H/P SYSTEM.....	25
TABLE 7-15 REFRIGERANT CHARGE FOR A/C SYSTEM.....	26
TABLE 7-16 & 7-17 REFRIGERANT CHARGE FOR H/P SYSTEM.....	26
TABLE 7-18 REFRIGERANT CHARGE FOR A/C SYSTEM.....	27
TABLE 7-19 & 7-20 REFRIGERANT CHARGE FOR H/P SYSTEM.....	27
TABLE 7-21 REFRIGERANT CHARGE FOR A/C SYSTEM.....	28
TABLE 7-22 & 7-23 REFRIGERANT CHARGE FOR H/P SYSTEM.....	28
TABLE 7-24 REFRIGERANT CHARGE FOR A/C SYSTEM.....	29
TABLE 7-25 & 7-26 REFRIGERANT CHARGE FOR H/P SYSTEM.....	29
TABLE 7-27 REFRIGERANT CHARGE FOR A/C SYSTEM.....	30
TABLE 7-28 & 7-29 REFRIGERANT CHARGE FOR H/P SYSTEM.....	30
TABLE 8-1 THERMOSTAT SIGNALS.....	33

LIST OF FIGURES

FIG. 2-1 COMPONENT LOCATION.....	5
FIG. 2-2 UNIT DIMENSIONS.....	6
FIG. 2-3 DIMENSIONS BACK AND BOTTOM.....	7
FIG. 2-4 ROOF CURB DIMENSION.....	8
FIG. 2-5 ROOF CURB DETAILS.....	9
FIG. 4-1 REMOVABLE OF CONDENSATE DRAIN PAN AND REMOVAL PROCEDURE.....	11
FIG. 6-1 TYPICAL FIELD CONTROL WIRING DIAGRAM.....	13
FIG. 6-2 TYPICAL FIELD POWER WIRING DIAGRAM.....	14
AC SYSTEM WIRING DIAGRAM (SINGLE PHASE).....	35
HP SYSTEM WIRING DIAGRAM (SINGLE PHASE).....	36
AC SYSTEM WIRING DIAGRAM (THREE PHASE).....	37
HP SYSTEM WIRING DIAGRAM (THREE PHASE).....	38

This document is customer property and is to remain with this unit. These instructions do not cover all the different variations of systems nor does it provide for every possible contingency to be met in connection with installation.

All phases of this installation must comply with NATION, STATE AND LOCAL CODES. If additional information is required please contact your local distributor.

1.0 SAFETY

When you see the symbols below on labels or in the manual, be alert to the potential or immediate hazards of personal injury, property and/or product damage. It is the owner's or installer's responsibility to comply with all safety instructions and information accompanying these symbols.



WARNING: This is a safety alert symbol indicating a potential hazardous situation, which could result in personal injury, property and/or product damage or death.



CAUTION: This is a safety alert symbol indicating a potential hazardous situation, which could result in moderate personal injury, and/or property and product damage.



WARNING

These instructions are intended as an aid to qualified, licensed service personnel for proper installation, adjustment and operation of this unit. Read these instructions thoroughly before attempting installation or operation. Failure to follow these instructions may result in improper installation, adjustment, service or maintenance possibly resulting in fire, electrical shock, property damage, personal injury or death.



WARNING

The manufacturer's warranty does not cover any damage or defect to the heat pump caused by the attachment or use of any components, accessories or devices (other than those authorized by the manufacturer) into, onto or in conjunction with the heat pump. You should be aware that the use of unauthorized components, accessories or devices may adversely affect the operation of the heat pump and may also endanger life and property. The manufacturer disclaims any responsibility for such loss or injury resulting from the use of such unauthorized components, accessories or devices.



WARNING

Disconnect all power to the unit before starting maintenance. Failure to do so can result in severe electrical shock or death.



WARNING

Do not, under any circumstances, connect return ductwork to any other heat producing device such as a fireplace insert, stove, etc. Unauthorized use of such devices may result in fire, carbon monoxide poisoning, explosion, property damage, severe personal injury or death.



WARNING

The unit must be permanently grounded. A grounding lug is provided. Failure to ground this unit can result in fire or electrical shock causing property damage, severe personal injury or death.



WARNING

Only electric heater kits supplied by this manufacturer as described in this publication have been designed, tested, and evaluated by a nationally recognized safety testing agency for use with this unit. Use of any other manufactured electric heaters installed within this unit may cause hazardous conditions resulting in property damage, fire, bodily injury or death.



WARNING

Proposition 65: This appliance contains fiberglass insulation. Respirable particles of fiberglass are known to the state of California to cause cancer.

1.1 INSPECTION

As soon as unit is received, it should be inspected and noted for possible shipping damage during transportation. It is carrier's responsibility to cover the cost of shipping damage. Manufacturer or distributor will not accept the claims from dealer for any transportation damage.

1.2 LIMITATIONS

Refer to *Fig. 2-2, 2-3* for unit physical data and to *Table 7-1* for electrical data. If components are to be added to a unit they must meet local codes, they are to be installed at the dealer's and /or the customer's expense. Size of unit for proposed installation should be based on heat loss / heat gain calculations made in accordance with industry recognized procedures identified by the Air conditioning contractors of America.

2.0 INSTALLATION

2.1 PRE-INSTALLATION

Before installation, carefully check the following:

1. Unit should be installed in accordance with national and local safety codes, including but not limit to ANSI/NFPA No. 70 or Canadian Electrical Code Part 1, C22.1, local plumbing and wastewater codes and any other applicable codes.
2. For rooftop installation, be sure the structure has enough strength to support the weight of unit. Unit should be installed on roof curb and leveled.
3. For ground level installation, a level slab should be used.
4. Condenser airflow should not be restricted.
5. On applications when a roof curb is used, the unit must be positioned on the curb so the front of the unit is tight against the curb.

2.2 CLEARANCE

All units require certain clearance for proper operation and service. Refer to *Table 2-1* for the clearances required for construction, servicing and proper unit operation.

2.3 RIGGING AND HANDING

Exercise care when moving the unit. Do not remove any packaging until the unit is near the place of installation. Rig the unit by attaching chain or cable slings to the lifting holes provided in the base rails. Spreader bars, whose length exceeds the largest dimension across the unit, **MUST** be used across the top of the unit.



CAUTION

Before lifting, make sure the unit weight is distributed equally on the rigging cables so it will lift evenly.

Units may be moved or lifted with a forklift. Slotted openings in the base rails are provided for this purpose.



CAUTION

All panels must be secured in place when the unit is lifted. The condenser coils should be protected from rigging cable damage with plywood or other suitable material.

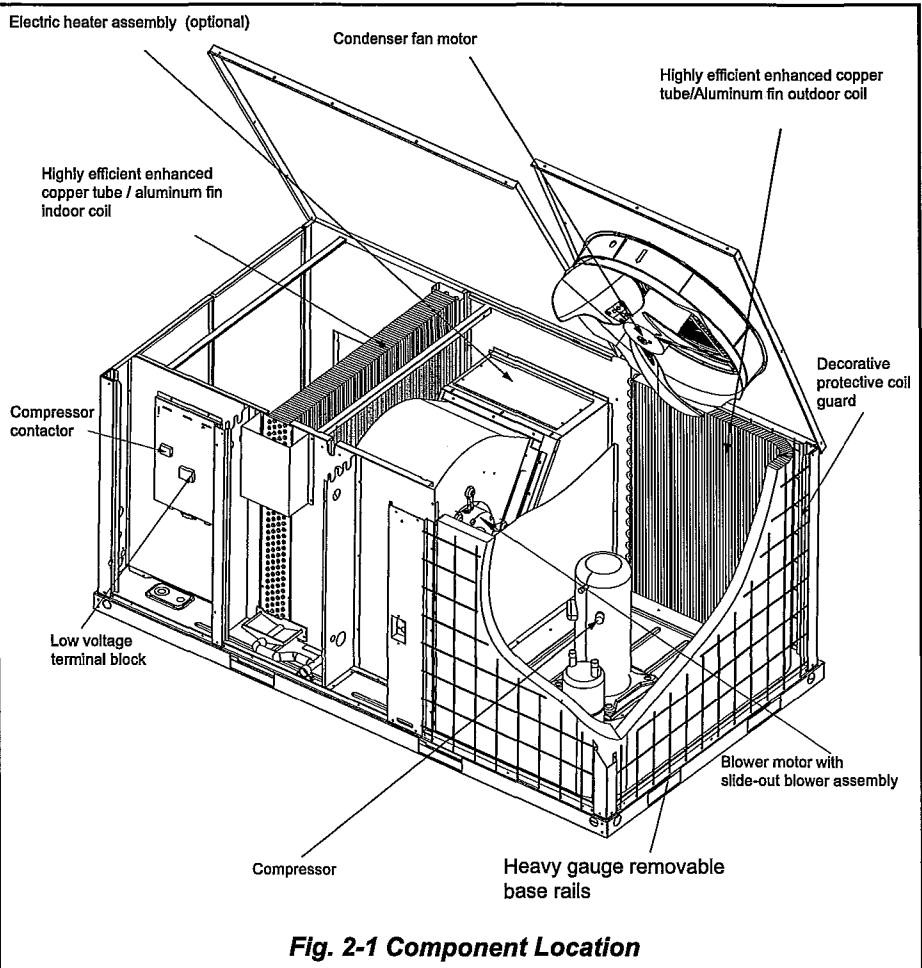

Fig. 2-1 Component Location

* The above figure for reference purpose only.

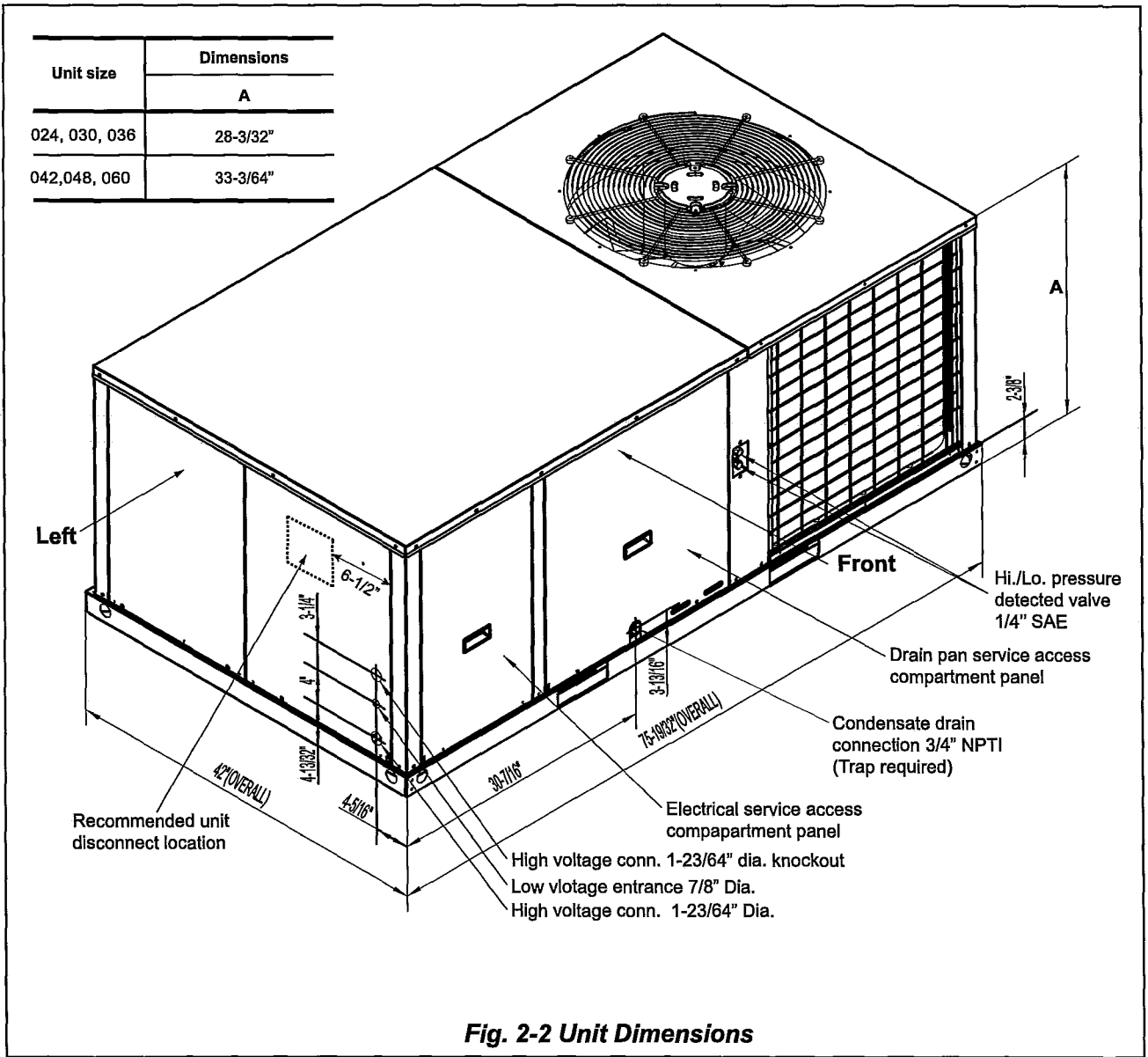

Fig. 2-2 Unit Dimensions

* The above figure for reference purpose only.

Table 2-1: Unit Clearance

Direction	Distance (in.)	Direction	Distance (in.)
Top ¹	60	Right	12
Front	30	Left	24
Rear	18 ²	Bottom ³	0

Duct clearance: 1 inch clearance for all sides of air supply duct.

- Units must be installed outdoors. Over hanging structure or shrubs should not obscure condenser air discharge outlet.
- The minimum clearance without economizer/fresh air damper. For distance with Economizer/fresh air damper, please refer to the relevant install requirement.
- Units may be installed on combustible floors made from wood or class A, B or C roof covering materials.

NOTE

For units applied with a roof curb, the minimum clearance may be reduced from 1 inch to 1/2 inch between combustible roof curb material and this supply air duct.

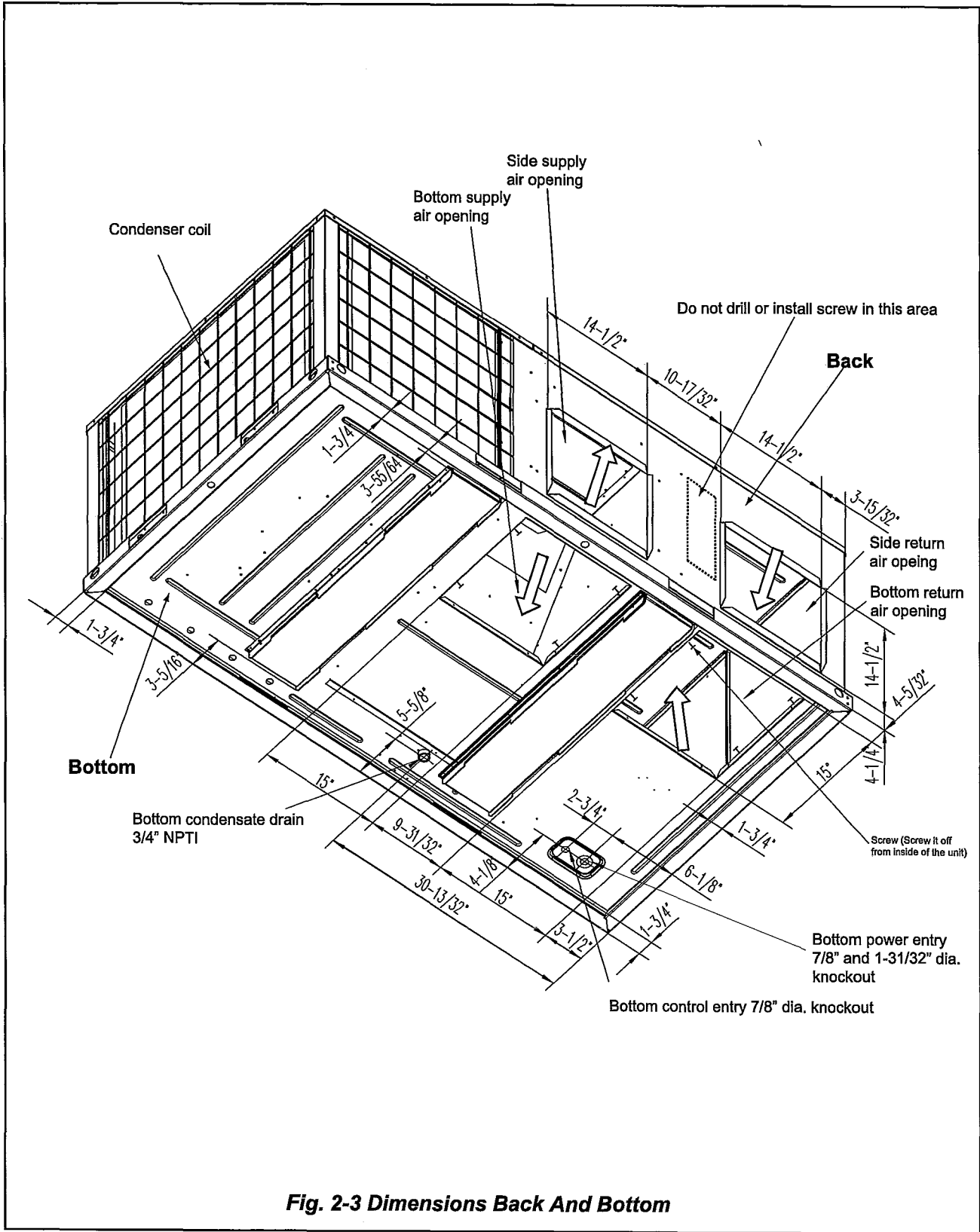
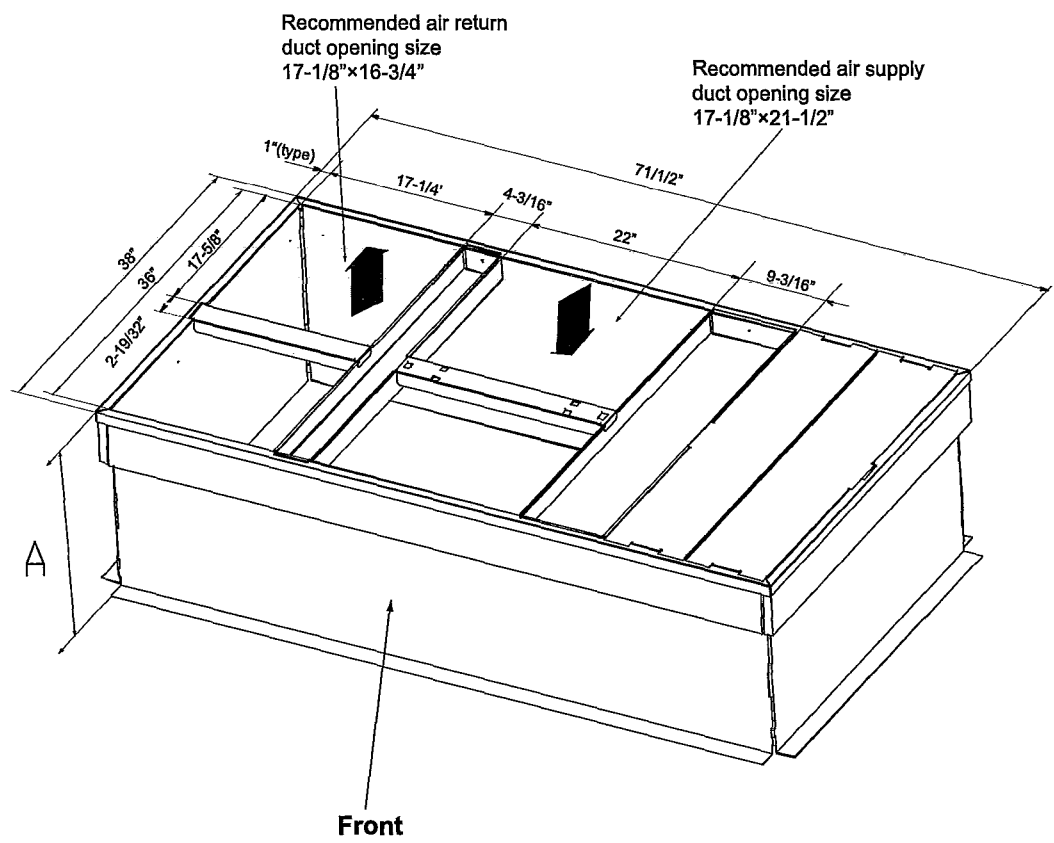

Fig. 2-3 Dimensions Back And Bottom

* The above figures for reference purpose only.

A Dimensions	8"
	14"



Supply and return air (including duct support rails) shown are typical for bottom duct applications. For location of horizontal duct applications (on back of unit), refer to unit dimension details.

Fig. 2-4 Roof Curb Dimension

* The above figures for reference purpose only.

NOTE
 Be sure to note supply and return openings.
 Refer to Fig. 2-3, 2-4 for information concerning rear and bottom supply and return air duct openings.

2.4 ROOF CURB

On applications when a roof curb is used, the unit must be positioned on the curb so the front of the unit is tight against the curb. (See Fig. 2-4 ROOF CURB DIMENSION)

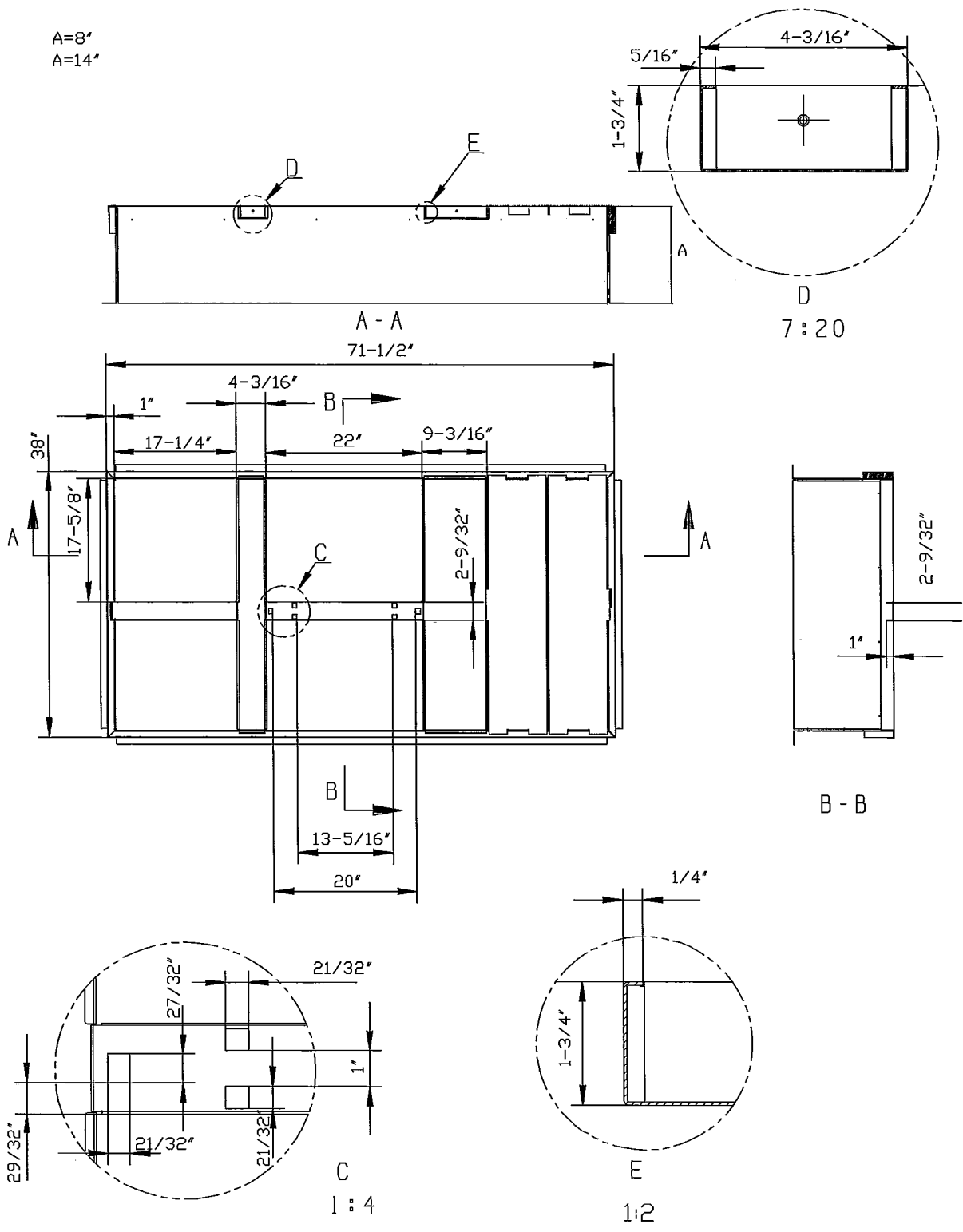

Fig.2-5 Roof Curb Details

3.0 DUCTWORK

Ductwork should be made and sized by installer and in accordance with Air Manual from Conditioning Contractors of America and local codes.



NOTE

On ductwork exposed to outside air conditioning space, use at least 2" of insulation and a vapor barrier. Flexible joint may be used to reduce noise.

These units are adaptable to downflow use as well as rear supply and return air duct openings. To convert to downflow, use the following steps:

1. Remove the duct covers found in the bottom return and supply air duct openings. There are four (4) screws securing each duct cover (save these to use in step 2).
2. Install the duct cover (removed in step one) to the rear supply and return air openings. Secure with the four (4) screws used in steps one.
3. Seal duct covers with silicone caulk.

A closed return duct system shall be used. This shall not preclude use of economizers or ventilation air intake. Flexible joints may be used in the supply and return duct work to minimize the transmission of noise.



CAUTION

When fastening duct work to the side duct flanges on the unit, insert the screws through the duct flanges only. DO NOT insert the screws through the casing. Outdoor duct work must be insulation and waterproofed.



NOTE

Be sure to note supply and return openings. Refer to Fig. 3 and 4 for information concerning rear and bottom supply and return air duct openings.

4.0 CONDENSATE DRAIN CONNECTION

Consult local codes for special requirements.

To provide extra protection from water damage, install an additional drain pan, provided by installer, under the entire unit with a separate drain line. Manufacturer will not be responsible for any damages due to the failure to follow these requirements.

4.1 INSTALL DRAIN PIPE

1. Use female NPT threaded fitting for outside connection and make sure that drain holes are not blocked.
2. Insulation may be needed for drain line to prevent sweating.
3. Drain pan has two drain connections on each side to provide flexibility of connection and drainage. Make sure proper pitch and plugging if second connection is not used.
4. Use a sealing compound on male pipe threads. Install the condensate drain line (NPT) to spill into an open drain.

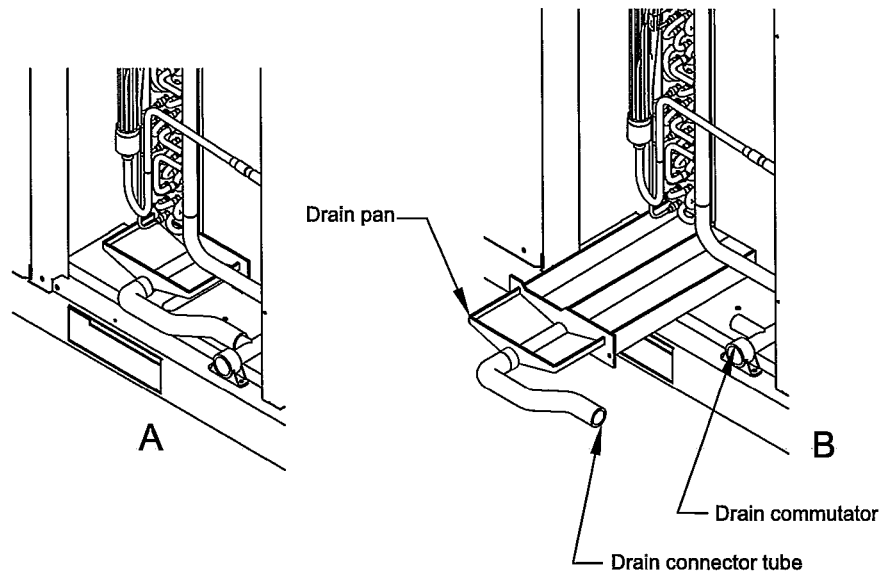

**Fig. 4-1 Removable Condensate Drain Pan
And Removal Procedure**

4.2 REMOVAL AND CLEAN THE DRAIN PAN

See above Figure.4-1 B, disconnect the Connective Tube and Drain Commutator, screw off the two fixed screws of Drain Pan, and then along with the rail pull out the Drain Pan and Connective Tube from the bottom of evaporator. Using a wet cloth or water to wash out the drain pan carefully.

5.0 FILTERS

Units are shipped without a filter or filter racks. It is the responsibility of the installer to secure a filter in the return air ductwork or install a filter/frame Kit.

Filter must always be used and must be kept clean. When filter become dirt laden, insufficient air will be delivered by the blower, decreasing your units efficiency and increasing operation costs and wear-and tear on the unit and controls.

Filters should be checked monthly; this is especially important since this unit is used for both heating and cooling.

6.0 ELECTRICAL WIRING

Field wiring must comply with the National Electric Code (NEC) or Canadian Electrical Code (CEC) and any applicable local ordinance.



WARNING

Disconnect all power to unit before installing or servicing. More than one disconnect switch may be required to de-energize the equipment. Hazardous voltage can cause severe personal injury or death.

6.1 POWER WIRING

1. Proper electrical power should be available at unit. Voltage tolerance should not be over 10% from rating voltage.
2. If any of the wire must be replaced, replacement wire must be the same type as shown in nameplate, wiring diagram and electrical data sheet.
3. Install a branch circuit disconnect of adequate size to handle starting current, located within sight of, and readily accessible to the unit.
4. **ELECTRIC HEATER** - If the Electric Heater is installed, unit may be equipped with 30~60A. circuit breakers or fuse. These breaker(s) protect the internal wiring in the event of a short circuit and serve as a disconnect. Circuit breakers installed within the unit do not provide over-current protection of the supply wiring and therefore may be sized larger than the branch circuit protection.
 - Supply circuit power wiring must be 221 °F minimum copper conductors only. See Electrical Data in this section for ampacity, wire size and circuit protector requirements. Supply circuit protective devices may be either fuses or "HACR" type circuit breakers.
 - An 1-3/8" knockouts inside cabinet is provided for connection of power wiring to electric heater.
 - Power wiring is connected to the power terminal block in unit electric cabinet.

See Electrical Heater Installation Instruction for details.

6.2 GROUNDING



WARNING

The unit must be permanently grounded. Failure to do so can result in electrical shock causing personal injury or death.

- Grounding may be accomplished by grounding metal conduit when installed in accordance with electrical codes to the unit cabinet.
- Grounding may also be accomplished by attaching ground wire(s) to ground lug(s) provided in the unit wiring compartment.

6.3 CONTROL WIRING

IMPORTANT: Class 2 low voltage control wiring **SHOULD NOT** be run in conduit with main power wiring and must be separated from power wiring, unless class 1 wire of proper voltage rating is used.

- Low voltage control wiring should be 18 AWG color-coded. For lengths longer than 50 ft, 16 AWG wire should be used.
- Two 7/8" holes can be used for control wires going into the unit, one on left side and one at the bottom.
- Make sure, after installation, separation of control wiring and power wiring has been maintained.

Thermostat should be mounted on an inside wall about 58" from floor and will not be affected by unconditioned air, sun and/or heat exposure. Follow the instruction carefully because there are many wiring requirements.

See Fig. 6-1 ~ 2, Table 7-1 ~ 4

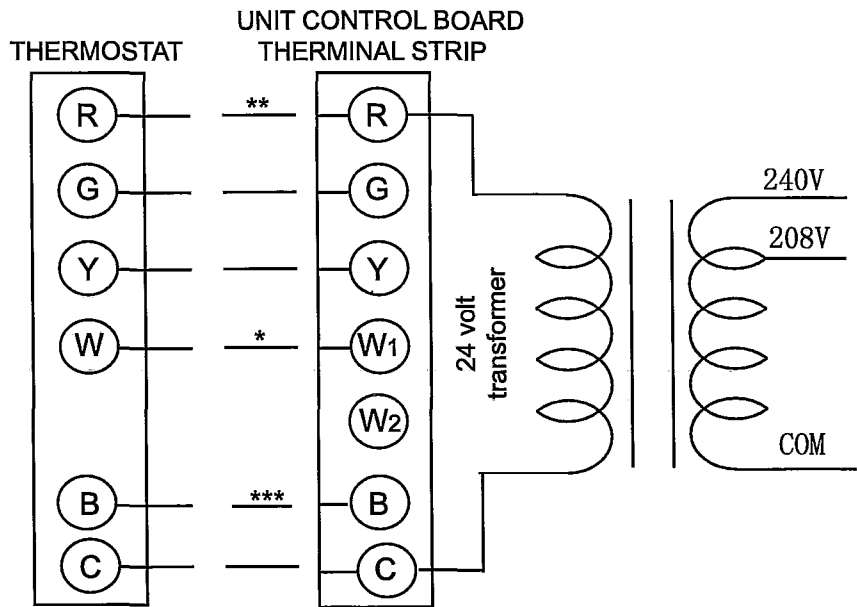
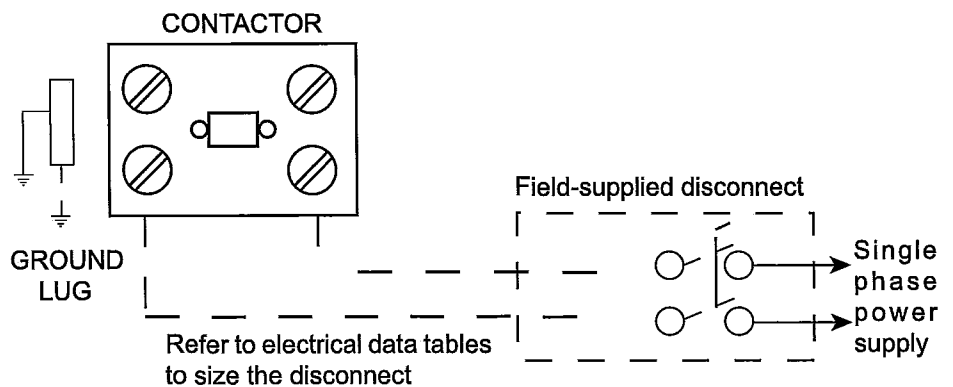

Fig. 6-1 Typical Field Control Wiring Diagram

- *** B wire be used with heat pump system only.
- ** Minimum wire size of 18 AWG wire should be used for all field installed 24 volt wire.
- * Only required on units with supplemental electric heat.

CAUTION

Label all wire prior to disconnection when servicing controls. Wiring errors can cause improper and dangerous operation. Verify proper operation after servicing.



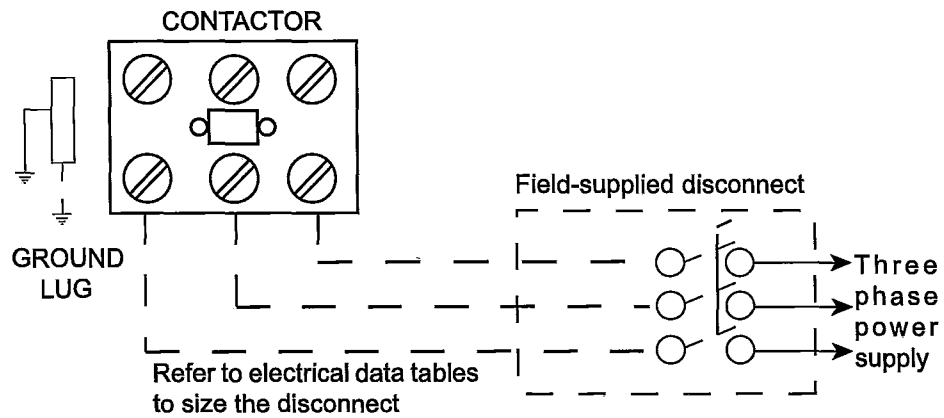

Fig. 6-2 Typical Field Power Wiring Diagram

Table 6-1: 13 SEER Heat Pump W/Without Electric Heat

Size (Tons)	Volt	Compressors (each)			OD Fan Motors (each)	Supply Blower Motor	Electric Heat Option				MCA1 (Amps)	Max Fuse2/ Breaker3 Size (Amps)
		RLA	LRA	MCC			FLA	FLA	Model	kW		
024 (2.0)	208/230-1-60	13.5A	58A	21.0A	0.57A	1.73A	None	-	-	None	19.3	30
							EHK-05C	3.8/5	1	18.1/20.8	41.9/45.3	50/50
							EHK-08C	5.6/7.5	1	27.1/31.3	53.2/58.4	60/60
							EHK-10C	7.5/10	1	36.1/41.7	64.4/71.4	70/80
036 (3.0)	208/230-1-60	16.7A	79A	26.0A	1.08A	2.45A	None	-	-	None	24.5	40
							EHK-05C	3.8/5	1	18.1/20.8	47.1/50.5	50/60
							EHK-08C	5.6/7.5	1	27.1/31.3	58.3/63.6	60/70
							EHK-10C	7.5/10	1	36.1/41.7	69.6/76.6	70/80
036 (3.0)	208/230-3-60	10.4A	73A	16.3A	1.08A	2.45A	None	-	-	None	16.6	25
							EHK-10D	7.5/10	1	20.9/24.1	42.7/46.7	45/50
							EHK-15D	11.3/15	2	31.4/36.1	55.8/61.7	60/70
							EHK-20C	15/20	2	41.7/48.2	74.6/82.7	80/90
042 (3.5)	208/230-1-60	17.9A	112A	28.0A	1.08A	3.53A	None	-	-	None	27	40
							EHK-05C	3.8/5	1	18.1/20.8	49.6/53	60/60
							EHK-08C	5.6/7.5	1	27.1/31.3	60.8/66.1	70/70
							EHK-10C	7.5/10	1	36.1/41.7	72.1/79.1	80/80
							EHK-15C	11.3/15	2	54.2/62.5	94.7/105.1	100/110
							EHK-20C	15/20	2	72.2/83.3	117.2/131.1	125/150
048 (4.0)	208/230-1-60	21.8A	117A	34.0A	1.74A	3.54A	None	-	-	None	32.6	50
							EHK-05C	3.8/5	1	18.1/20.8	55.2/58.6	70/70
							EHK-08C	5.6/7.5	1	27.1/31.3	66.5/71.7	80/80
							EHK-10C	7.5/10	1	36.1/41.7	77.7/84.7	90/90
							EHK-15C	11.3/15	2	54.2/62.5	100.3/110.7	110/125
							EHK-20C	15/20	2	72.2/83.3	122.8/136.7	150/150
048 (4.0)	208/230-3-60	13.7A	83.1A	21.4A	1.74A	3.54A	None	-	-	None	22.5	35
							EHK-10D	7.5/10	1	20.9/24.1	48.6/52.6	50/60
							EHK-15D	11.3/15	2	31.4/36.1	61.7/67.6	70/70
							EHK-20D	15/20	2	41.7/48.2	74.6/82.7	80/90
060 (5.0)	208/230-1-60	26.4A	134A	41.2A	1.74A	3.92A	None	-	-	None	38.7	60
							EHK-05C	3.8/5	1	18.1/20.8	61.3/64.7	80/80
							EHK-08C	5.6/7.5	1	27.1/31.3	72.6/77.8	90/90
							EHK-10C	7.5/10	1	36.1/41.7	83.8/90.8	100/100
							EHK-15C	11.3/15	2	54.2/62.5	108.5/116.8	110/125
060 (5.0)	208/230-3-60	16A	110.0A	24.9A	1.74A	3.92A	None	-	-	None	25.7	40
							EHK-10D	7.5/10	1	20.9/24.1	51.8/55.8	60/60
							EHK-15D	11.3/15	2	31.4/36.1	65/70.8	70/80
							EHK-20D	15/20	2	41.7/48.2	77.8/86	80/90

Table 6-2: 13 SEER Cooling only W/Without Electric Heat

Size (Tons)	Volt	Compressors (each)			OD Fan Motors (each)	Supply Blower Motor	Electric Heat Option				MCA1 (Amps)	Max Fuse2/ Breaker3 Size (Amps)
		RLA	LRA	MCC	FLA	FLA	Model	kW	Stages	Amps		
024 (2.0)	208/230-1-60	13.5A	58A	21.0A	0.57A	1.73A	None	-	-	None	19.3	30
							EHK-05C	3.8/5	1	18.1/20.8	24.8/28.2	30/30
							EHK-08C	5.6/7.5	1	27.1/31.3	36.1/41.3	40/45
							EHK-10C	7.5/10	1	36.1/41.7	47.3/54.3	50/60
036 (3.0)	208/230-1-60	16.7A	79A	26.0A	1.08A	2.45A	None	-	-	None	24.5	40
							EHK-05C	3.8/5	1	18.1/20.8	25.4/29.1	40/40
							EHK-08C	5.6/7.5	1	27.1/31.3	37.0/42.2	40/45
							EHK-10C	7.5/10	1	36.1/41.7	48.2/55.2	50/60
036 (3.0)	208/230-3-60	10.4A	73A	16.3A	1.08A	2.45A	EHK-15C	11.3/15	2	54.2/62.5	70.9/81.2	80/90
							None	-	-	None	16.6	25
							EHK-10D	7.5/10	1	20.9/24.1	29.2/33.2	30/35
036 (3.0)	208/230-3-60	10.4A	73A	16.3A	1.08A	2.45A	EHK-15D	11.3/15	2	31.4/36.1	42.4/48.2	45/50
							None	-	-	None	27	40
042 (3.5)	208/230-1-60	17.9A	112A	28.0A	1.08A	3.53A	EHK-05C	3.8/5	1	18.1/20.8	27.1/30.5	40/40
							EHK-08C	5.6/7.5	1	27.1/31.3	38.3/43.6	40/45
							EHK-10C	7.5/10	1	36.1/41.7	49.6/56.6	50/60
							EHK-15C	11.3/15	2	54.2/62.5	72.2/82.6	80/90
							EHK-20C	15/20	2	72.2/83.3	94.7/108.6	100/110
							None	-	-	None	32.6	50
048 (4.0)	208/230-1-60	21.8A	117A	34.0A	1.74A	3.54A	EHK-05C	3.8/5	1	18.1/20.8	32.6/32.6	50/50
							EHK-08C	5.6/7.5	1	27.1/31.3	38.3/43.6	50/50
							EHK-10C	7.5/10	1	36.1/41.7	49.6/56.6	50/60
							EHK-15C	11.3/15	2	54.2/62.5	72.2/82.6	80/90
							EHK-20C	15/20	2	72.2/83.3	94.7/108.6	100/110
							None	-	-	None	22.5	35
048 (4.0)	208/230-3-60	13.7A	83.1A	21.4A	1.74A	3.54A	EHK-10D	7.5/10	1	20.9/24.1	30.6/34.6	35/35
							EHK-15D	11.3/15	2	31.4/36.1	43.7/49.6	45/50
							EHK-20D	15/20	2	41.7/48.2	56.6/64.7	60/70
							None	-	-	None	38.7	60
060 (5.0)	208/230-1-60	26.4A	134A	41.2A	1.74A	3.92A	EHK-05C	3.8/5	1	18.1/20.8	38.7/38.7	60/60
							EHK-08C	5.6/7.5	1	27.1/31.3	38.8/44.1	60/60
							EHK-10C	7.5/10	1	36.1/41.7	50.1/57.1	60/60
							EHK-15C	11.3/15	2	54.2/62.5	72.7/83.1	80/90
							EHK-20C	15/20	2	72.2/83.3	95.2/109.1	100/110
							EHK-25C	18.8/25	2	90.3/104.2	117.8/135.2	125/150
060 (5.0)	208/230-3-60	16A	110.0A	24.9A	1.74A	3.92A	None	-	-	None	25.7	40
							EHK-10D	7.5/10	1	20.9/24.1	31.1/35.1	40/40
							EHK-15D	11.3/15	2	31.4/36.1	44.2/50.1	45/60
							EHK-20D	15/20	2	41.7/48.2	57.1/65.2	60/70
							EHK-25D	18.8/25	2	52.2/60.2	70.2/80.2	80/90

1. Minimum Circuit Ampacity.
2. Maximum Over Current Protection per Standard UL 1995.
3. Fuse or HACR circuit breaker size installed at factory or field installed.

Table 6-3: 13 SEER Physical Data

Component	Models					
	MRB-24CWN1-M13	MRB-24HWN1-M13	MRB-30CWN1-M13	MRB-30HWN1-M13	MRB-36CWN1-M13	MRB-36HWN1-M13
Nominal Tonnage	2.0	2.0	2.5	2.5	3.0	3.0
ARI COOLING PERFORMANCE						
Gross Capacity @ ARI A point (Btu)	24,644	24,444	30,313	29,913	37,363	37,563
ARI net capacity (Btu)	23,600	23,400	29,000	28,600	35,800	36,000
EER	11	11	12	12	11.5	11.5
SEER	13	13	13	13	13	13
Nominal CFM	835	835	1050	1050	1250	1250
System power (kW)	2.14	2.12	2.35	2.42	3.11	3.13
Refrigerant type	R410a	R410a	R410a	R410a	R410a	R410a
Refrigerant charge (lb-oz)	4-7	4-10	6-6	6-10	6-10	7-15
ARI HEATING PERFORMANCE						
47°F Capacity rating (Btu)	—	21,600	—	28,800	—	36,000
System power (kW)	—	1.75	—	2.24	—	2.95
17°F Capacity rating (Btu)	—	11,300	—	16,200	—	19,600
System power (kW)	—	1.6	—	2.04	—	2.76
HSPF (BTU/Watts-hr.)	—	7.7	—	8.0	—	7.7
DIMENSIONS (Inches)						
Length	75-19/32	75-19/32	75-19/32	75-19/32	75-19/32	75-19/32
Width	42	42	42	42	42	42
Height	28-3/32	28-3/32	28-3/32	28-3/32	28-3/32	28-3/32
OPERATING WT. (lbs)	410	419	432	441	432	441
COMPRESSORS						
Type	Scroll 1-spd	Scroll 1-spd	Scroll 1-spd	Scroll 1-spd	Scroll 1-spd	Scroll 1-spd
Quantity	1	1	1	1	1	1
CONDENSER COIL DATA						
Face area (Sq. Ft)	14.49	14.49	14.49	14.49	14.49	14.49
Rows	1	1	2	2	2	2
Fins per inch	20	20	20	20	20	20
Tube diameter	9/32	9/32	9/32	9/32	9/32	9/32
Circuitry type	interlaced	interlaced	interlaced	interlaced	interlaced	interlaced
EVAPORATOR COIL DATA						
Face area (Sq. Ft)	5.15	5.15	5.15	5.15	5.15	5.15
Rows	2	2	3	3	3	3
Fins per inch	16	16	16	16	16	16
Tube diameter	5/16	5/16	5/16	5/16	5/16	5/16
Circuitry type	interlaced	interlaced	interlaced	interlaced	interlaced	interlaced
Refrigerant control	Orifice	Orifice	Orifice	Orifice	Orifice	Orifice
CONDENSER FAN DATA						
Fan diameter (inch)	23-5/8	23-5/8	23-5/8	23-5/8	23-5/8	23-5/8
Type	Prop	Prop	Prop	Prop	Prop	Prop
Drive type	Direct	Direct	Direct	Direct	Direct	Direct
No. speeds	1	1	1	1	1	1
Number of motors	1	1	1	1	1	1
Motor HP each	1/12	1/12	1/6	1/6	1/6	1/6
RPM	1075	1075	825	825	825	825
Nominal total CFM	2440	2440	3145	3145	3145	3145
DIRECT DRIVE EVAP FAN DATA						
Quantity	1	1	1	1	1	1
Fan Size (Inch)	10×10	10×10	10×10	10×10	10×10	10×10
Type	Centrifugal	Centrifugal	Centrifugal	Centrifugal	Centrifugal	Centrifugal
No. speeds	3	3	3	3	3	3
Motor HP each	1/4	1/4	1/3	1/3	1/2	1/2
RPM	1075	1075	1075	1075	1075	1075
Motor frame size	48	48	48	48	48	48
FILTERS						
(No.) Size Recommended in.	(1) 22×14×1	(1) 22×14×1	(1) 22×14×1	(1) 22×14×1	(1) 22×14×1	(1) 22×14×1

Component	Models					
	MRB-36CWN1-X13	MRB-36HWN1-X13	MRB-42CWN1-M13	MRB-42HWN1-M13	MRB-48CWN1-M13C	MRB-48HWN1-M13C
Nominal Tonnage	3.0	3.0	3.5	3.5	4.0	4.0
ARI COOLING PERFORMANCE						
Gross Capacity @ ARI A point (Btu)	37,563	35,963	41,813	41,813	49,500	50,000
ARI net capacity (Btu)	36,000	34,400	40,000	40,000	47,500	48,000
EER	11.5	11	11	11	11	11
SEER	13	13	13	13	13	13
Nominal CFM	1250	1250	1450	1450	1600	1600
System power (kW)	3.07	3.12	3.60	3.60	4.31	4.36
Refrigerant type	R410a	R410a	R410a	R410a	R410a	R410a
Refrigerant charge (lb-oz)	7-4	7-15	8-2	8-13	7-12	9-1
ARI HEATING PERFORMANCE						
47°F Capacity rating (Btu)	—	36,000	—	41,500	—	48,000
System power (kW)	—	3.03	—	3.16	—	3.9
17°F Capacity rating (Btu)	—	19,300	—	23,800	—	28,800
System power (kW)	—	2.48	—	2.86	—	3.56
HSPF (BTU/Watts-hr.)	—	7.7	—	7.7	—	7.7
DIMENSIONS (Inches)						
Length	75-19/32	75-19/32	75-19/32	75-19/32	75-19/32	75-19/32
Width	42	42	42	42	42	42
Height	28-3/32	28-3/32	33-3/64	33-3/64	33-3/64	33-3/64
OPERATING WT. (lbs)	432	441	496	505	496	505
COMPRESSORS						
Type	Scroll 1-spd	Scroll 1-spd	Scroll 1-spd	Scroll 1-spd	Scroll 1-spd	Scroll 1-spd
Quantity	1	1	1	1	1	1
CONDENSER COIL DATA						
Face area (Sq. Ft)	14.49	14.49	17.39	17.39	17.39	17.39
Rows	2	2	2	2	2	2
Fins per inch	20	20	20	20	20	20
Tube diameter	9/32	9/32	9/32	9/32	9/32	9/32
Circuitry type	interlaced	interlaced	interlaced	interlaced	interlaced	interlaced
EVAPORATOR COIL DATA						
Face area (Sq. Ft)	5.15	5.15	6.34	6.34	6.34	6.34
Rows	2	2	3	3	3	3
Fins per inch	16	16	16	16	16	16
Tube diameter	5/16	5/16	5/16	5/16	5/16	5/16
Circuitry type	interlaced	interlaced	interlaced	interlaced	interlaced	interlaced
Refrigerant control	Orifice	Orifice	Orifice	Orifice	Orifice	Orifice
CONDENSER FAN DATA						
Fan diameter (inch)	23-5/8	23-5/8	23-5/8	23-5/8	23-5/8	23-5/8
Type	Prop	Prop	Prop	Prop	Prop	Prop
Drive type	Direct	Direct	Direct	Direct	Direct	Direct
No. speeds	1	1	1	1	1	1
Number of motors	1	1	1	1	1	1
Motor HP each	1/6	1/6	1/6	1/6	1/3	1/3
RPM	825	825	825	825	1075	1075
Nominal total CFM	3145	3145	3145	3145	4245	4245
DIRECT DRIVE EVAP FAN DATA						
Quantity	1	1	1	1	1	1
Fan Size (Inch)	10×10	10×10	10×10	10×10	10×10	10×10
Type	Centrifugal	Centrifugal	Centrifugal	Centrifugal	Centrifugal	Centrifugal
No. speeds	3	3	3	3	3	3
Motor HP each	1/2	1/2	3/4	3/4	3/4	3/4
RPM	1075	1075	904	904	1075	1075
Motor frame size	48	48	48	48	48	48
FILTERS						
(No.) Size Recommended in.	(1) 22×14×1	(1) 22×14×1	(1) 22×14×1	(1) 22×14×1	(1) 22×14×1	(1) 22×14×1

Component	Models					
	MRB-48CWN1-X13	MRB-48HWN1-X13	MRB-60CWN1-M13	MRB-60HWN1-M13	MRB-60CWN1-X13	MRB-60HWN1-X13
Nominal Tonnage	4.0	4.0	5.0	5.0	5.0	5.0
ARI COOLING PERFORMANCE						
Gross Capacity @ ARI A point (Btu)	49,000	47,500	61,906	62,350	59,850	59,850
ARI net capacity (Btu)	47,000	45,500	59,500	60,000	57,500	57,500
EER	11.5	11	11	11	10.5	10.5
SEER	13	13	13	13	13	13
Nominal CFM	1600	1600	1880	1880	1880	1880
System power (kW)	4.08	4.15	5.40	5.45	5.28	5.30
Refrigerant type	R410a	R410a	R410a	R410a	R410a	R410a
Refrigerant charge (lb-oz)	7-11	8-13	9-11	10-9	8-6	9-4
ARI HEATING PERFORMANCE						
47°F Capacity rating (Btu)	—	48,000	—	60,000	—	59,500
System power (kW)	—	3.74	—	4.8	—	4.54
17°F Capacity rating (Btu)	—	27,600	—	35,200	—	32,800
System power (kW)	—	3.30	—	4.32	—	4.08
HSPF (BTU/Watts-hr.)	—	7.7	—	7.7	—	7.7
DIMENSIONS (Inches)						
Length	75-19/32	75-19/32	75-19/32	75-19/32	75-19/32	75-19/32
Width	42	42	42	42	42	42
Height	33-3/64	33-3/64	33-3/64	33-3/64	33-3/64	33-3/64
OPERATING WT. (lbs)	496	505	507	516	507	516
COMPRESSORS						
Type	Scroll 1-spd	Scroll 1-spd	Scroll 1-spd	Scroll 1-spd	Scroll 1-spd	Scroll 1-spd
Quantity	1	1	1	1	1	1
CONDENSER COIL DATA						
Face area (Sq. Ft)	17.39	17.39	17.39	17.39	17.39	17.39
Rows	2	2	3	3	2	2
Fins per inch	20	20	20	20	20	20
Tube diameter	9/32	9/32	9/32	9/32	9/32	9/32
Circuitry type	interlaced	interlaced	interlaced	interlaced	interlaced	interlaced
EVAPORATOR COIL DATA						
Face area (Sq. Ft)	6.34	6.34	6.34	6.34	6.34	6.34
Rows	3	3	4	4	4	4
Fins per inch	16	16	16	16	16	16
Tube diameter	5/16	5/16	5/16	5/16	5/16	5/16
Circuitry type	interlaced	interlaced	interlaced	interlaced	interlaced	interlaced
Refrigerant control	Orifice	Orifice	Orifice	Orifice	Orifice	Orifice
CONDENSER FAN DATA						
Fan diameter (inch)	23-5/8	23-5/8	23-5/8	23-5/8	23-5/8	23-5/8
Type	Prop	Prop	Prop	Prop	Prop	Prop
Drive type	Direct	Direct	Direct	Direct	Direct	Direct
No. speeds	1	1	1	1	1	1
Number of motors	1	1	1	1	1	1
Motor HP each	1/3	1/3	1/3	1/3	1/3	1/3
RPM	1075	1075	1075	1075	1075	1075
Nominal total CFM	4245	4245	4245	4245	4245	4245
DIRECT DRIVE EVAP FAN DATA						
Quantity	1	1	1	1	1	1
Fan Size (Inch)	10×10	10×10	10×10	10×10	10×10	10×10
Type	Centrifugal	Centrifugal	Centrifugal	Centrifugal	Centrifugal	Centrifugal
No. speeds	3	3	3	3	3	3
Motor HP each	3/4	3/4	1	1	1	1
RPM	1075	1075	1075	1075	1075	1075
Motor frame size	48	48	48	48	48	48
FILTERS						
(No.) Size Recommended in.	(1) 22×14×1	(1) 22×14×1	(1) 22×14×1	(1) 22×14×1	(1) 22×14×1	(1) 22×14×1

* The above Table data for reference only.

7.0 AIRFLOW PERFORMANCE

Airflow performance data is based on cooling performance with a coil and no filter in place. Use this performance table for appropriate unit size, external static applied to unit and allow operation within the minimum and maximum limits shown in table below for both cooling and electric heat operation.

7.1 AIRFLOW PERFORMANCE DATA

Table 7-1 Side Duct Application

Model Number	Motor Speed	CFM(L/S) (Watts)									
		External Static Pressure (Inches W.C. / kPa)									
		0[0]	0.1[.02]	0.2[.05]	0.3[.07]	0.4[.10]	0.5[.12]	0.6[.15]	0.7[.17]		
24	Low	CFM(L/S)	952(449)	885 (417)	818 (386)	738(348)	653 (308)	554 (261)	463(218)	342(161)	
		RPM	442	506	574	644	712	782	845	911	
		Watts	196	194	191	187	182	175	169	160	
	Middle	Amps	0.86	0.85	0.83	0.81	0.79	0.77	0.74	0.7	
		CFM(L/S)	1229(580)	1169(551)	1111(524)	1045(493)	972(458)	890(420)	786(371)	657(310)	
		RPM	558	612	662	712	765	812	861	921	
	High	Watts	296	292	289	284	278	269	259	245	
		Amps	1.29	1.27	1.26	1.24	1.21	1.18	1.14	1.08	
		CFM(L/S)	1470(693)	1408(664)	1345(634)	1277(602)	1201(566)	1111(524)	1011(477)	901(425)	
	30	Low	RPM	659	703	743	783	821	861	898	935
			Watts	397	390	384	377	368	356	344	329
			Amps	1.73	1.71	1.68	1.65	1.62	1.58	1.53	1.47
Middle		CFM(L/S)	1164(550)	1103(521)	1051(496)	990(468)	918(433)	778(368)	671(317)	572(270)	
		RPM	572	630	684	734	788	860	904	941	
		Watts	278	272	266	258	250	236	226	216	
High		Amps	1.24	1.22	1.21	1.18	1.16	1.12	1.1	1.07	
		CFM(L/S)	1292(611)	1228(580)	1180(557)	1123(530)	1064(503)	982(464)	808(381)	697(329)	
		RPM	624	675	725	769	814	861	925	961	
36		Low	Watts	337	326	317	308	299	288	270	257
			Amps	1.5	1.47	1.45	1.42	1.4	1.37	1.32	1.29
			CFM(L/S)	1499(708)	1441(681)	1384(654)	1331(629)	1270(600)	1190(562)	1092(516)	891(421)
	Middle	RPM	709	753	793	831	866	902	939	988	
		Watts	441	432	423	414	404	390	375	347	
		Amps	2.01	1.98	1.96	1.93	1.9	1.87	1.83	1.76	
	High	CFM(L/S)	1341(633)	1286(607)	1242(586)	1193(563)	1134(535)	1063(502)	895(425)	775(366)	
		RPM	630	676	720	764	809	854	927	960	
		Watts	361	355	348	340	331	319	298	284	
	42	Low	Amps	1.57	1.55	1.52	1.51	1.46	1.41	1.34	1.29
			CFM(L/S)	1510(713)	1468(693)	1420(671)	1369(647)	1292(610)	1218(575)	1128(533)	934(441)
			RPM	701	741	779	814	854	892	928	987
Middle		Watts	447	438	428	419	408	394	377	347	
		Amps	1.95	1.92	1.88	1.84	1.8	1.75	1.69	1.59	
		CFM(L/S)	1705(805)	1658(783)	1604(758)	1549(731)	1489(703)	1416(669)	1321(624)	1179(557)	
High		RPM	781	815	849	880	908	938	969	1006	
		Watts	558	547	536	524	511	493	474	445	
		Amps	2.45	2.41	2.36	2.32	2.26	2.21	2.14	2.04	
48		Low	CFM(L/S)	1556(740)	1519(717)	1488(703)	1409(665)	1336(631)	1263(596)	1060(501)	856(404)
			RPM	714	761	798	824	850	876	891	906
			Watts	473	459	452	434	420	405	370	335
	Middle	Amps	2.08	2.03	2.01	1.96	1.93	1.86	1.77	1.67	
		CFM(L/S)	1771(836)	1716(811)	1653(781)	1598(755)	1529(722)	1444(682)	1329(628)	1214(573)	
		RPM	794	833	870	886	905	926	939	952	
	High	Watts	589	574	560	543	524	509	486	462	
		Amps	2.63	2.58	2.53	2.48	2.43	2.38	2.32	2.25	
		CFM(L/S)	2010(949)	1937(915)	1865(881)	1793(847)	1688(797)	1599(755)	1491(704)	1382(653)	
	High	RPM	917	940	960	972	985	1000	1010	1017	
		Watts	759	740	720	700	680	657	633	608	
		Amps	3.44	3.4	3.32	3.27	3.21	3.15	3.08	3.00	

* The above airflow data for reference only.

Model Number	Motor Speed	CFM(L/S)(Watts)								
		External Static Pressure (Inches W.C.)(kPa)								
		0[0]	0.1[02]	0.2[05]	0.3[07]	0.4[10]	0.5[12]	0.6[15]	0.7[17]	
48	Low	CFM(L/S)	1658 (783)	1603 (757)	1546 (730)	1491 (704)	1427 (674)	1354 (639)	1265 (598)	1125 (531)
		RPM	747	779	811	843	871	903	932	972
		Watts	510	500	489	478	464	449	431	405
		Amps	2.33	2.3	2.26	2.23	2.19	2.14	2.09	2.02
	Middle	CFM(L/S)	1837 (868)	1776 (839)	1724 (814)	1647 (778)	1576 (744)	1502 (709)	1413 (667)	1295 (611)
		RPM	816	845	869	894	918	942	964	992
		Watts	615	602	587	575	558	542	522	498
		Amps	2.84	2.8	2.76	2.72	2.67	2.63	2.58	2.51
	High	CFM(L/S)	2019 (954)	1954 (923)	1892 (893)	1819 (859)	1745 (825)	1656 (782)	1565 (739)	1459 (689)
		RPM	891	910	931	949	968	986	1002	1020
		Watts	756	741	723	706	689	672	649	627
		Amps	3.54	3.5	3.45	3.41	3.35	3.3	3.23	3.16
60	Low	CFM(L/S)	2064 (975)	2004 (946)	1942 (917)	1875 (886)	1806 (853)	1726 (815)	1643 (776)	1538 (726)
		RPM	905	929	953	974	993	1011	1028	1045
		Watts	731	712	687	666	643	618	595	570
		Amps	3.19	3.11	3.03	2.94	2.86	2.77	2.69	2.61
	Middle	CFM(L/S)	2177 (1028)	2111 (997)	2041 (964)	1971 (931)	1886 (891)	1806 (853)	1704 (804)	1604 (758)
		RPM	955	973	992	1007	1021	1036	1052	1065
		Watts	807	779	751	730	703	679	651	624
		Amps	3.54	3.43	3.34	3.26	3.16	3.08	2.98	2.89
	High	CFM(L/S)	2277 (1075)	2209 (1043)	2135 (1008)	2056 (971)	1974 (932)	1881 (888)	1781 (841)	1668 (788)
		RPM	998	1012	1023	1036	1049	1060	1071	1082
		Watts	878	852	828	801	777	747	719	687
		Amps	3.92	3.81	3.72	3.64	3.53	3.43	3.33	3.22

Table 7-2 Bottom Duct Application

Model Number	Motor Speed	CFM(L/S)(Watts)								
		External Static Pressure (Inches W.C.)(kPa)								
		0[0]	0.1[02]	0.2[05]	0.3[07]	0.4[10]	0.5[12]	0.6[15]	0.7[17]	
24	Low	CFM(L/S)	952(449)	885 (417)	818 (386)	738(348)	653 (308)	554 (261)	463(218)	342(161)
		RPM	442	506	574	644	712	782	845	911
		Watts	196	194	191	187	182	175	169	160
		Amps	0.86	0.85	0.83	0.81	0.79	0.77	0.74	0.7
	Middle	CFM(L/S)	1229(580)	1169(551)	1111(524)	1045(493)	972(458)	890(420)	786(371)	657(310)
		RPM	558	612	662	712	765	812	861	921
		Watts	296	292	289	284	278	269	259	245
		Amps	1.29	1.27	1.26	1.24	1.21	1.18	1.14	1.08
	High	CFM(L/S)	1470(693)	1408(664)	1345(634)	1277(602)	1201(566)		1011(477)	901(425)
		RPM	659	703	743	783	821	861	898	935
		Watts	397	390	384	377	368	356	344	329
		Amps	1.73	1.71	1.68	1.65	1.62	1.58	1.53	1.47
30	Low	CFM(L/S)	1164(550)	1103(521)	1051(496)	990(468)	918(433)	778(368)	671(317)	572(270)
		RPM	572	630	684	734	788	860	904	941
		Watts	278	272	266	258	250	236	226	216
		Amps	1.24	1.22	1.21	1.18	1.16	1.12	1.1	1.07
	Middle	CFM(L/S)	1292(611)	1228(580)	1180(557)	1123(530)	1064(503)	982(464)	808(381)	697(329)
		RPM	624	675	725	769	814	861	925	961
		Watts	337	326	317	308	299	288	270	257
		Amps	1.5	1.47	1.45	1.42	1.4	1.37	1.32	1.29
	High	CFM(L/S)	1499(708)	1441(681)	1384(654)	1331(629)	1270(600)	1190(562)	1092(516)	891(421)
		RPM	709	753	793	831	866	902	939	988
		Watts	441	432	423	414	404	390	375	347
		Amps	2.01	1.98	1.96	1.93	1.9	1.87	1.83	1.76
36	Low	CFM(L/S)	1341(633)	1286(607)	1242(586)	1193(563)	1134(535)	1063(502)	895(425)	775(366)
		RPM	630	676	720	764	809	854	927	960
		Watts	361	355	348	340	331	319	298	284
		Amps	1.57	1.55	1.52	1.51	1.46	1.41	1.34	1.29
	Middle	CFM(L/S)	1510(713)	1468(693)	1420(671)	1369(647)	1292(610)	1218(575)	1128(533)	934(441)
		RPM	701	741	779	814	854	892	928	987
		Watts	447	438	428	419	408	394	377	347
		Amps	1.95	1.92	1.88	1.84	1.8	1.75	1.69	1.59
	High	CFM(L/S)	1705(805)	1658(783)	1604(758)	1549(731)	1489(703)	1416(669)	1321(624)	1179(557)
		RPM	781	815	849	880	908	938	969	1006
		Watts	558	547	536	524	511	493	474	445
		Amps	2.45	2.41	2.36	2.32	2.26	2.21	2.14	2.04

Model Number	Motor Speed	CFM(L/S)(Watts)								
		External Static Pressure (Inches W.C.)(KPa)								
			0[0]	0.1[.02]	0.2[.05]	0.3[.07]	0.4[.10]	0.5[.12]	0.6[.15]	0.7[.17]
42	Low	CFM(L/S)	1556(740)	1519(717)	1488(703)	1409(665)	1336(631)	1263(596)	1060(501)	856(404)
		RPM	714	761	798	824	850	876	891	906
		Watts	473	459	452	434	420	405	370	335
		Amps	2.08	2.03	2.01	1.96	1.93	1.86	1.77	1.67
	Middle	CFM(L/S)	1771(836)	1716(811)	1653(781)	1598(755)	1529(722)	1444(682)	1329(628)	1214(573)
		RPM	794	833	870	886	905	926	939	952
		Watts	589	574	560	543	524	509	486	462
		Amps	2.63	2.58	2.53	2.48	2.43	2.38	2.32	2.25
	High	CFM(L/S)	2010(949)	1937(915)	1865(881)	1793(847)	1688(797)	1599(755)	1491(704)	1382(653)
		RPM	917	940	960	972	985	1000	1010	1017
		Watts	759	740	720	700	680	657	633	608
		Amps	3.44	3.4	3.32	3.27	3.21	3.15	3.08	3.00
48	Low	CFM(L/S)	1658 (783)	1603 (757)	1546 (730)	1491 (704)	1427 (674)	1354 (639)	1265 (598)	1125 (531)
		RPM	747	779	811	843	871	903	932	972
		Watts	510	500	489	478	464	449	431	405
		Amps	2.33	2.3	2.26	2.23	2.19	2.14	2.09	2.02
	Middle	CFM(L/S)	1837 (868)	1776 (839)	1724 (814)	1647 (778)	1576 (744)	1502 (709)	1413 (667)	1295 (611)
		RPM	816	845	869	894	918	942	964	992
		Watts	615	602	587	575	558	542	522	498
		Amps	2.84	2.8	2.76	2.72	2.67	2.63	2.58	2.51
	High	CFM(L/S)	2019 (954)	1954 (923)	1892 (893)	1819 (859)	1745 (825)	1656 (782)	1565 (739)	1459 (689)
		RPM	891	910	931	949	968	986	1002	1020
		Watts	756	741	723	706	689	672	649	627
		Amps	3.54	3.5	3.45	3.41	3.35	3.3	3.23	3.16
60	Low	CFM(L/S)	2064 (975)	2004 (946)	1942 (917)	1875 (886)	1806 (853)	1726 (815)	1643 (776)	1538 (726)
		RPM	905	929	953	974	993	1011	1028	1045
		Watts	731	712	687	666	643	618	595	570
		Amps	3.19	3.11	3.03	2.94	2.86	2.77	2.69	2.61
	Middle	CFM(L/S)	2177 (1028)	2111 (997)	2041 (964)	1971 (931)	1886 (891)	1806 (853)	1704 (804)	1604 (758)
		RPM	955	973	992	1007	1021	1036	1052	1065
		Watts	807	779	751	730	703	679	651	624
		Amps	3.54	3.43	3.34	3.26	3.16	3.08	2.98	2.89
	High	CFM(L/S)	2277 (1075)	2209 (1043)	2135 (1008)	2056 (971)	1974 (932)	1881 (888)	1781 (841)	1668 (788)
		RPM	998	1012	1023	1036	1049	1060	1071	1082
		Watts	878	852	828	801	777	747	719	687
		Amps	3.92	3.81	3.72	3.64	3.53	3.43	3.33	3.22

* The above airflow data for reference only.

- The air distribution system has the greatest effect on airflow. The duct system is totally controlled by the contractor. For this reason, the contractor should use only industry-recognized procedures.
- Heat pump systems require a specified airflow. Each ton of cooling requires between 350 and 450 cubic feet of air per minute (CFM), or 400 CFM nominally.
- Duct design and construction should be carefully done. System performance can be lowered dramatically through bad planning or workmanship.
- Air supply diffusers must be selected and located carefully. They must be sized and positioned to deliver treated air along the perimeter of the space. If they are too small for their intended airflow, they become noisy. If they are not located properly, they cause drafts. Return air grilles must be properly sized to carry air back to the blower. If they are too small, they also cause noise.
- The installers should balance the air distribution system to ensure proper quiet airflow to all rooms in the home. This ensures a comfortable living space.
- An air velocity meter or airflow hood can give a reading of system CFM.
- When installation, installer should select the air speed according to the actual setting static pressure. Please refer to the *Table 7-1, 7-2 AIRFLOW PERFORMANCE DATA*.

Table 7-3 Refrigerant charge for A/C system

MRB-24CWN1-M13 Cooling Mode Mode De Refroidissement		Cooling Charge Chart/Tableau De Charge de Refroidissement													
		Outdoor Ambient Temperature(F)/Temperature Amdiante Exterieur(en F)													
		55	60	65	70	75	80	85	90	95	100	105	110	115	
Low Pressure Detected Valve(psig)	Vanne Détectée de Pression Basse(en psig)	High Pressure Detected Valve(psig)/Vanne Détecté de Pression Haute(en psig)													
		165			303	316	328	350	370	400	426	446	465	487	508
		161			300	313	325	346	366	394	421	440	459	481	503
		157			297	310	322	342	362	389	415	434	453	476	499
		153		282	294	307	319	339	358	384	410	428	446	471	496
		149		279	291	304	316	335	353	374	399	419	443	468	493
		145		275	287	300	312	331	349	370	393	416	440	465	490
		141	256	272	284	297	309	328	346	368	389	413	437	462	486
		137	251	268	280	293	305	324	343	365	386	410	434	459	483
		133	246	264	276	289	301	321	340	361	382	406	430	455	479
		129	241	260	272	285	297	317	336	357	378	403	427	451	475
		125	236	256	268	281	293	313	332	353	374	399	423	447	471
		121	231	252	264	277	289	309	328	349	370	395	420	444	467
		117	226	248	260	273	285	305	324	345	366	392	417	440	463
		113	221	244	256	269	281	301	320	341	362	388	414	437	459
109	216	240	252	265	277	297	316	337	358	385	411	433	455		
105	211	236	248	261	273	293	312	333	354	381	408	429	450		

Table 7-4 Refrigerant charge for H/P system

MRB-24HWN1-M13 Cooling Mode Mode De Refroidissement		Cooling Charge Chart/Tableau De Charge de Refroidissement													
		Outdoor Ambient Temperature(F)/Temperature Amdiante Exterieur(en F)													
		55	60	65	70	75	80	85	90	95	100	105	110	115	
Low Pressure Detected Valve(psig)	Vanne Détectée de Pression Basse(en psig)	High Pressure Detected Valve(psig)/Vanne Détecté de Pression Haute(en psig)													
		165			303	316	328	350	370	400	426	446	465	487	508
		161			300	313	325	346	366	394	421	440	459	481	503
		157			297	310	322	342	362	389	415	434	453	476	499
		153		282	294	307	319	339	358	384	410	428	446	471	496
		149		279	291	304	316	335	353	374	399	419	443	468	493
		145		275	287	300	312	331	349	370	393	416	440	465	490
		141	256	272	284	297	309	328	346	368	389	413	437	462	486
		137	251	268	280	293	305	324	343	365	386	410	434	459	483
		133	246	264	276	289	301	321	340	361	382	406	430	455	479
		129	241	260	272	285	297	317	336	357	378	403	427	451	475
		125	236	256	268	281	293	313	332	353	374	399	423	447	471
		121	231	252	264	277	289	309	328	349	370	395	420	444	467
		117	226	248	260	273	285	305	324	345	366	392	417	440	463
		113	221	244	256	269	281	301	320	341	362	388	414	437	459
109	216	240	252	265	277	297	316	337	358	385	411	433	455		
105	211	236	248	261	273	293	312	333	354	381	408	429	450		

Table 7-5 Refrigerant charge for H/P system

MRB-24HWN1-M13 Heating Mode Mode De Chauffage		Heating Charge Chart/Tableau De Charge de Chauffage													
		Indoor Dry Bulb Temperature(F)/Temperature Interieur au Themometre sec(en F)													
		60	62	64	66	68	70	72	74	76	78	80	82		
Low Pressure Detected Valve(psig)	Vanne Détectée de Pression Basse(en psig)	High Pressure Detected Valve(psig)/Vanne Détecté de Pression Haute(en psig)													
		135	322	328	334	340	346	352	362	371	380	389	398	416	
		128	315	320	326	332	337	342	351	360	369	378	387	405	
		121	308	313	319	324	330	336	340	347	354	362	377	395	
		114	301	306	310	315	319	324	330	337	344	351	368	386	
		107	294	297	300	304	308	312	320	327	334	341	360	378	
		100	287	291	294	297	300	303	310	317	324	332	345	363	
		93	280	282	285	288	291	294	299	307	315	324	330	348	
		86	271	274	277	280	283	286	295	302	309	316	323	341	
		79	259	262	265	268	271	274	285	294	301	308	316	334	
		72	250	254	257	260	263	266	279	286	293	300	307	325	
		65	242	245	248	252	255	258	265	272	279	287	295	313	
		58			245	248	252	257	272	277	282	287	305		
		51				237	241	248	255	263	270	278	296		
		44					230	238	246	254	258	270	288		
37						226	236	242	248	262	280				
30															

Table 7-6 Refrigerant charge for A/C system

MRB-30CWN1-M13 Cooling Mode Mode De Refroidissement		Cooling Charge Chart/Tableau De Charge de Refroidissement												
		Outdoor Ambient Temperature(F)/Temperature Amiante Exterieur(en F)												
		55	60	65	70	75	80	85	90	95	100	105	110	115
Low Pressure Detected Valve(psig) Vanne Détectée de Pression Basse(en psig)		Lipuid Pressure at Small Service Valve(psig)/Pression lipuide a la petite vanne di service(en psig)												
		165			236	256	278	299	321	346	370	392	414	439
161			232	254	276	298	319	342	366	388	410	434	458	
157			231	253	275	296	317	340	364	386	408	431	453	
153		208	230	252	273	294	314	337	360	383	405	428	450	
149		207	228	250	272	292	312	335	357	380	402	426	449	
145		205	227	249	270	291	311	333	355	377	399	423	446	
141	180	202	224	246	268	288	308	330	352	373	395	418	442	
137	177	198	220	242	264	284	304	323	342	367	391	415	439	
133	175	196	218	240	262	282	302	324	346	367	388	412	437	
129	172	194	215	237	259	279	299	320	341	363	385	410	434	
125	169	191	213	235	256	276	296	316	337	358	380	405	430	
121	167	189	210	232	254	274	294	314	334	356	378	403	429	
117	164	186	208	230	251	271	292	311	331	353	374	400	426	
113	161	182	204	226	248	268	288	307	327	348	370	396	422	
109	159	181	202	224	246	266	286	305	324	346	367	394	420	
105	156	178	200	221	243	263	284	302	321	343	364	391	418	

Table 7-7 Refrigerant charge for H/P system

MRB-30HWN1-M13 Cooling Mode Mode De Refroidissement		Cooling Charge Chart/Tableau De Charge de Refroidissement												
		Outdoor Ambient Temperature(F)/Temperature Amiante Exterieur(en F)												
		55	60	65	70	75	80	85	90	95	100	105	110	115
Low Pressure Detected Valve(psig) Vanne Détectée de Pression Basse(en psig)		Lipuid Pressure at Small Service Valve(psig)/Pression lipuide a la petite vanne di service(en psig)												
		165			236	256	278	299	321	346	370	392	414	439
161			232	254	276	298	319	342	366	388	410	434	458	
157			231	253	275	296	317	340	364	386	408	431	453	
153		208	230	252	273	294	314	337	360	383	405	428	450	
149		207	228	250	272	292	312	335	357	380	402	426	449	
145		205	227	249	270	291	311	333	355	377	399	423	446	
141	180	202	224	246	268	288	308	330	352	373	395	418	442	
137	177	198	220	242	264	284	304	323	342	367	391	415	439	
133	175	196	218	240	262	282	302	324	346	367	388	412	437	
129	172	194	215	237	259	279	299	320	341	363	385	410	434	
125	169	191	213	235	256	276	296	316	337	358	380	405	430	
121	167	189	210	232	254	274	294	314	334	356	378	403	429	
117	164	186	208	230	251	271	292	311	331	353	374	400	426	
113	161	182	204	226	248	268	288	307	327	348	370	396	422	
109	159	181	202	224	246	266	286	305	324	346	367	394	420	
105	156	178	200	221	243	263	284	302	321	343	364	391	418	

Table 7-8 Refrigerant charge for H/P system

MRB-30HWN1-M13 Cooling Mode Mode De Refroidissement		Cooling Charge Chart/Tableau De Charge de Refroidissement												
		Outdoor Ambient Temperature(F)/Temperature Amiante Exterieur(en F)												
		55	60	65	70	75	80	85	90	95	100	105	110	115
Low Pressure Detected Valve(psig) Vanne Détectée de Pression Basse(en psig)		Lipuid Pressure at Small Service Valve(psig)/Pression lipuide a la petite vanne di service(en psig)												
		165			236	256	278	299	321	346	370	392	414	439
161			232	254	276	298	319	342	366	388	410	434	458	
157			231	253	275	296	317	340	364	386	408	431	453	
153		208	230	252	273	294	314	337	360	383	405	428	450	
149		207	228	250	272	292	312	335	357	380	402	426	449	
145		205	227	249	270	291	311	333	355	377	399	423	446	
141	180	202	224	246	268	288	308	330	352	373	395	418	442	
137	177	198	220	242	264	284	304	323	342	367	391	415	439	
133	175	196	218	240	262	282	302	324	346	367	388	412	437	
129	172	194	215	237	259	279	299	320	341	363	385	410	434	
125	169	191	213	235	256	276	296	316	337	358	380	405	430	
121	167	189	210	232	254	274	294	314	334	356	378	403	429	
117	164	186	208	230	251	271	292	311	331	353	374	400	426	
113	161	182	204	226	248	268	288	307	327	348	370	396	422	
109	159	181	202	224	246	266	286	305	324	346	367	394	420	
105	156	178	200	221	243	263	284	302	321	343	364	391	418	

Table 7-9 Refrigerant charge for A/C system

MRB-36CWN1-M13 Cooling Mode Mode De Refroidissement		Cooling Charge Chart/Tableau De Charge de Refroidissement													
		Outdoor Ambient Temperature(F)/Temperature Amdiante Exterieur(en F)													
		55	60	65	70	75	80	85	90	95	100	105	110	115	
Low Pressure Detected Valve(psig)	Vanne Détectée de Pression Basse(en psig)	High Pressure Detected Valve(psig)/Vanne Détecté de Pression Haute(en psig)													
		165			308	323	338	352	365	386	407	432	456	482	508
		161			304	319	334	348	361	382	403	428	452	478	503
		157			300	315	330	344	357	378	399	423	447	473	499
		153		281	296	311	326	340	353	374	395	419	443	469	495
		149		277	292	307	322	336	349	370	391	415	439	465	490
		145		273	288	303	318	332	345	367	388	412	435	461	487
		141	248	269	284	299	314	328	341	363	385	408	431	457	482
		137	243	265	280	295	310	325	339	360	381	405	428	458	488
		133	238	261	276	291	306	321	336	357	378	402	425	450	474
		129	233	257	272	287	302	318	334	355	375	399	422	448	473
		125	228	253	268	283	298	314	330	352	373	396	419	444	469
		121	223	249	264	279	294	310	326	348	370	393	416	441	465
		117	218	245	260	275	290	306	322	345	367	390	413	437	461
		113	213	241	256	271	286	302	318	341	364	387	410	434	457
		109	208	237	252	267	282	298	314	338	361	384	407	430	453
105	203	233	248	263	278	294	310	334	358	381	404	427	449		

Table 7-10 Refrigerant charge for H/P system

MRB-36HWN1-M13 Cooling Mode Mode De Refroidissement		Cooling Charge Chart/Tableau De Charge de Refroidissement													
		Outdoor Ambient Temperature(F)/Temperature Amdiante Exterieur(en F)													
		55	60	65	70	75	80	85	90	95	100	105	110	115	
Low Pressure Detected Valve(psig)	Vanne Détectée de Pression Basse(en psig)	High Pressure Detected Valve(psig)/Vanne Détecté de Pression Haute(en psig)													
		165			308	323	338	352	365	386	407	432	456	482	508
		161			304	319	334	348	361	382	403	428	452	478	503
		157			300	315	330	344	357	378	399	423	447	473	499
		153		281	296	311	326	340	353	374	395	419	443	469	495
		149		277	292	307	322	336	349	370	391	415	439	465	490
		145		273	288	303	318	332	345	367	388	412	435	461	487
		141	248	269	284	299	314	328	341	363	385	408	431	457	482
		137	243	265	280	295	310	325	339	360	381	405	428	458	488
		133	238	261	276	291	306	321	336	357	378	402	425	450	474
		129	233	257	272	287	302	318	334	355	375	399	422	448	473
		125	228	253	268	283	298	314	330	352	373	396	419	444	469
		121	223	249	264	279	294	310	326	348	370	393	416	441	465
		117	218	245	260	275	290	306	322	345	367	390	413	437	461
		113	213	241	256	271	286	302	318	341	364	387	410	434	457
		109	208	237	252	267	282	298	314	338	361	384	407	430	453
105	203	233	248	263	278	294	310	334	358	381	404	427	449		

Table 7-11 Refrigerant charge for H/P system

MRB-36HWN1-M13 Heating Mode Mode De Chauffage		Heating Charge Chart/Tableau De Charge de Chauffage													
		Indoor Dry Bulb Temperature(F)/Temperature Interieur au Themometre sec(en F)													
		60	62	64	66	68	70	72	74	76	78	80	82		
Low Pressure Detected Valve(psig)	Vanne Détectée de Pression Basse(en psig)	High Pressure Detected Valve(psig)/Vanne Détecté de Pression Haute(en psig)													
		135	336	347	358	369	380	392	399	406	413	420	424	432	
		128	328	339	350	361	372	384	390	396	402	408	413	421	
		121	320	331	342	353	364	376	381	386	391	396	402	410	
		114	313	324	335	346	351	358	363	370	377	384	391	399	
		107	305	313	321	329	337	345	352	359	366	373	380	388	
		100	295	303	311	319	327	335	342	349	356	363	369	377	
		93	286	294	301	309	316	323	330	337	344	351	358	366	
		86	277	284	291	298	305	312	319	326	333	340	347	355	
		79	267	274	280	287	294	300	307	314	321	328	336	344	
		72	258	265	271	277	283	289	296	303	311	318	326	334	
		65	248	254	260	266	272	278	285	293	300	307	315	323	
		58					260	268	275	283	290	297	305	313	
		51						259	266	273	280	287	294	302	
		44							256	263	270	277	284	292	
		37								258	265	272	279	287	
		30													

Table 7-12 Refrigerant charge for A/C system

MRB-36CWN1-X13 Cooling Mode Mode De Refroidissement		Cooling Charge Chart/Tableau De Charge de Refroidissement													
		Outdoor Ambient Temperature(F)/Temperature Amiante Exterieur(en F)													
		55	60	65	70	75	80	85	90	95	100	105	110	115	
Low Pressure Detected Valve (psig)	Vanne Détectée de Pression Basse(en psig)	165			280	300	322	341	359	382	402	427	455	479	503
		161			277	296	319	338	356	380	401	424	451	475	500
		157			274	294	316	334	352	376	398	422	448	472	496
		153		249	271	291	313	331	349	374	395	418	444	469	494
		149		246	268	288	310	328	346	371	392	415	441	467	493
		145		244	265	285	308	325	342	367	389	413	439	464	488
		141	225	237	259	280	303	322	340	366	388	411	437	460	484
		137	220	233	256	277	300	320	339	364	386	408	432	457	481
		133	210	232	254	274	297	317	337	360	380	403	429	454	480
		129	208	230	252	273	296	314	333	357	378	401	426	452	478
		125	206	228	250	270	293	311	329	354	376	398	424	450	477
		121	203	225	247	267	290	308	326	351	373	395	421	448	475
		117	200	222	244	264	287	305	323	348	370	393	418	445	472
		113	198	219	241	261	284	302	320	345	367	390	415	443	470
		109	197	215	238	258	281	299	317	343	366	387	412	440	469
105	194	211	234	255	279	296	314	341	365	385	409	438	468		

Table 7-13 Refrigerant charge for H/P system

MRB-36HWN1-X13 Cooling Mode Mode De Refroidissement		Cooling Charge Chart/Tableau De Charge de Refroidissement													
		Outdoor Ambient Temperature(F)/Temperature Amiante Exterieur(en F)													
		55	60	65	70	75	80	85	90	95	100	105	110	115	
Low Pressure Detected Valve (psig)	Vanne Détectée de Pression Basse(en psig)	165			280	300	322	341	359	382	402	427	455	479	503
		161			277	296	319	338	356	380	401	424	451	475	500
		157			274	294	316	334	352	376	398	422	448	472	496
		153		249	271	291	313	331	349	374	395	418	444	469	494
		149		246	268	288	310	328	346	371	392	415	441	467	493
		145		244	265	285	308	325	342	367	389	413	439	464	488
		141	225	237	259	280	303	322	340	366	388	411	437	460	484
		137	220	233	256	277	300	320	339	364	386	408	432	457	481
		133	210	232	254	274	297	317	337	360	380	403	429	454	480
		129	208	230	252	273	296	314	333	357	378	401	426	452	478
		125	206	228	250	270	293	311	329	354	376	398	424	450	477
		121	203	225	247	267	290	308	326	351	373	395	421	448	475
		117	200	222	244	264	287	305	323	348	370	393	418	445	472
		113	198	219	241	261	284	302	320	345	367	390	415	443	470
		109	197	215	238	258	281	299	317	343	366	387	412	440	469
105	194	211	234	255	279	296	314	341	365	385	409	438	468		

Table 7-14 Refrigerant charge for H/P system

MRB-36HWN1-X13 Heating Mode Mode De Chauffage		Heating Charge Chart/Tableau De Charge de Chauffage													
		Indoor Dry Bulb Temperature(F)/Temperature Interieur au Themometre sec(en F)													
		60	62	64	66	68	70	72	74	76	78	80	82		
Low Pressure Detected Valve (psig)	Vanne Détectée de Pression Basse(en psig)	135	362	370	377	383	391	397	406	418	426	435	447	455	
		128	354	361	369	374	383	388	397	409	417	426	438	446	
		121	344	352	359	365	373	379	388	401	410	420	432	435	
		114	335	343	350	356	364	370	379	390	399	407	419	423	
		107	326	333	340	344	352	357	366	377	386	394	406	414	
		100	309	318	326	333	342	349	357	368	376	384	395	403	
		93	300	309	318	324	334	341	348	358	366	373	383	392	
		86	291	300	308	315	324	331	338	348	355	362	372	381	
		79	285	292	300	306	314	320	327	337	344	351	361	370	
		72	278	285	292	297	305	310	317	326	333	339	349	359	
		65	262	270	278	285	294	300	306	315	322	328	337	348	
		58				274	283	290	296	305	311	317	327	337	
		51					274	279	285	294	301	307	316	326	
		44						270	276	285	292	298	307	315	
		37							267	276	281	287	296	304	
		30													

Table 7-15 Refrigerant charge for A/C system

MRB-42CWN1-M13 Cooling Mode Mode De Refroidissement		Cooling Charge Chart/Tableau De Charge de Refroidissement													
		Outdoor Ambient Temperature(F)/Temperature Amiante Exterieur(en F)													
		55	60	65	70	75	80	85	90	95	100	105	110	115	
Low Pressure Detected Valve(psig)		High Pressure Detected Valve(psig)/Vanne Déteçté de Pression Haute(en psig)													
		Vanne Déteçté de Pression Basse(en psig)													
Low Pressure Detected Valve(psig)	Vanne Déteçté de Pression Basse(en psig)	165			302	322	341	363	381	408	429	450	467	493	518
		161			297	318	338	358	379	401	423	444	464	488	512
		157			293	313	336	356	376	397	419	439	460	483	506
		153		270	289	309	333	353	373	394	416	436	455	479	503
		149		265	285	305	330	350	370	391	412	432	451	476	500
		145		261	281	300	326	347	367	388	408	427	447	472	496
		141	238	258	277	296	325	344	364	384	404	423	442	467	492
		137	234	254	273	292	321	341	361	381	400	419	437	463	488
		133	230	250	268	287	316	337	358	377	396	414	433	458	484
		129	226	246	264	283	313	334	355	373	391	409	428	454	480
		125	222	242	260	278	309	330	351	369	386	405	423	450	476
		121	218	238	256	274	305	326	348	365	381	400	419	445	471
		117	215	234	252	270	302	323	344	361	379	397	415	441	467
		113	211	230	248	265	297	319	340	357	374	392	410	437	463
109	207	226	244	261	294	315	337	353	370	388	406	432	458		
105	203	222	240	257	290	312	333	349	365	384	402	428	454		

Table 7-16 Refrigerant charge for H/P system

MRB-42HWN1-M13 Cooling Mode Mode De Refroidissement		Cooling Charge Chart/Tableau De Charge de Refroidissement													
		Outdoor Ambient Temperature(F)/Temperature Amiante Exterieur(en F)													
		55	60	65	70	75	80	85	90	95	100	105	110	115	
Low Pressure Detected Valve(psig)		High Pressure Detected Valve(psig)/Vanne Déteçté de Pression Haute(en psig)													
		Vanne Déteçté de Pression Basse(en psig)													
Low Pressure Detected Valve(psig)	Vanne Déteçté de Pression Basse(en psig)	165			302	322	341	363	381	408	429	450	467	493	518
		161			297	318	338	358	379	401	423	444	464	488	512
		157			293	313	336	356	376	397	419	439	460	483	506
		153		270	289	309	333	353	373	394	416	436	455	479	503
		149		265	285	305	330	350	370	391	412	432	451	476	500
		145		261	281	300	326	347	367	388	408	427	447	472	496
		141	238	258	277	296	325	344	364	384	404	423	442	467	492
		137	234	254	273	292	321	341	361	381	400	419	437	463	488
		133	230	250	268	287	316	337	358	377	396	414	433	458	484
		129	226	246	264	283	313	334	355	373	391	409	428	454	480
		125	222	242	260	278	309	330	351	369	386	405	423	450	476
		121	218	238	256	274	305	326	348	365	381	400	419	445	471
		117	215	234	252	270	302	323	344	361	379	397	415	441	467
		113	211	230	248	265	297	319	340	357	374	392	410	437	463
109	207	226	244	261	294	315	337	353	370	388	406	432	458		
105	203	222	240	257	290	312	333	349	365	384	402	428	454		

Table 7-17 Refrigerant charge for H/P system

MRB-42HWN1-M13 Heating Mode Mode De Chauffage		Heating Charge Chart/Tableau De Charge de Chauffage													
		Indoor Dry Bulb Temperature(F)/Temperature Interieur au Themometre sec(en F)													
		60	62	64	66	68	70	72	74	76	78	80	82		
Low Pressure Detected Valve(psig)		High Pressure Detected Valve(psig)/Vanne Déteçté de Pression Haute(en psig)													
		Vanne Déteçté de Pression Basse(en psig)													
Low Pressure Detected Valve(psig)	Vanne Déteçté de Pression Basse(en psig)	135	358	376	389	403	416	429	441	450	459	468	477	486	
		128	348	365	379	392	405	418	429	437	446	454	463	471	
		121	336	354	366	379	392	405	416	424	433	441	450	458	
		114	326	342	354	366	378	390	401	409	417	425	434	442	
		107	315	330	342	354	365	377	387	395	403	411	419	427	
		100	304	319	330	341	352	363	373	381	389	396	404	412	
		93	293	307	318	328	339	350	360	367	374	382	389	396	
		86	281	295	305	316	326	336	346	353	360	367	374	381	
		79	271	285	295	305	315	326	335	342	350	357	364	371	
		72	261	274	285	295	305	315	325	332	339	347	354	361	
		65	251	264	274	284	294	304	314	321	329	336	344	351	
		58							303	311	318	326	334	341	
		51								299	307	314	322	330	
		44									297	304	312	319	
		37										294	302	309	
		30											292	299	

Table 7-18 Refrigerant charge for A/C system

MRB-48CWN1-M13C Cooling Mode Mode De Refroidissement		Cooling Charge Chart/Tableau De Charge de Refroidissement												
		Outdoor Ambient Temperature(F)/Temperature Amdiante Exterieur(en F)												
		55	60	65	70	75	80	85	90	95	100	105	110	115
Low Pressure Detected Valve(psig) Vanne Détectée de Pression Basse(en psig)		High Pressure Detected Valve(psig)/Vanne Détecté de Pression Haute(en psig)												
		165			289	309	329	351	373	391	410	436	461	485
161			286	306	326	348	369	388	406	432	457	481	505	
157			283	303	323	344	366	385	404	428	452	478	503	
153		260	280	300	320	341	362	381	400	425	449	475	500	
149		256	277	297	317	338	359	378	398	422	445	471	496	
145		253	274	294	314	335	355	375	395	419	442	466	490	
141		249	270	290	311	332	352	373	393	416	438	461	484	
137	233	245	266	286	307	328	348	369	390	411	432	456	480	
133	230	245	265	285	305	325	345	365	385	406	427	453	478	
129	227	246	265	284	303	322	341	360	379	402	424	450	476	
125	224	243	262	281	300	318	336	356	376	399	421	448	475	
121	220	239	258	277	296	314	331	352	372	396	419	446	472	
117	215	234	254	273	292	309	326	348	369	393	416	442	468	
113	207	227	247	267	287	304	321	344	367	390	412	438	464	
109	202	222	243	263	283	299	316	340	363	386	408	434	460	
105	197	218	238	258	278	295	311	335	359	382	405	431	456	

Table 7-19 Refrigerant charge for H/P system

MRB-48HWN1-M13C Cooling Mode Mode De Refroidissement		Cooling Charge Chart/Tableau De Charge de Refroidissement												
		Outdoor Ambient Temperature(F)/Temperature Amdiante Exterieur(en F)												
		55	60	65	70	75	80	85	90	95	100	105	110	115
Low Pressure Detected Valve(psig) Vanne Détectée de Pression Basse(en psig)		High Pressure Detected Valve(psig)/Vanne Détecté de Pression Haute(en psig)												
		165			289	309	329	351	373	391	410	436	461	485
161			286	306	326	348	369	388	406	432	457	481	505	
157			283	303	323	344	366	385	404	428	452	478	503	
153		260	280	300	320	341	362	381	400	425	449	475	500	
149		256	277	297	317	338	359	378	398	422	445	471	496	
145		253	274	294	314	335	355	375	395	419	442	466	490	
141		249	270	290	311	332	352	373	393	416	438	461	484	
137	233	245	266	286	307	328	348	369	390	411	432	456	480	
133	230	245	265	285	305	325	345	365	385	406	427	453	478	
129	227	246	265	284	303	322	341	360	379	402	424	450	476	
125	224	243	262	281	300	318	336	356	376	399	421	448	475	
121	220	239	258	277	296	314	331	352	372	396	419	446	472	
117	215	234	254	273	292	309	326	348	369	393	416	442	468	
113	207	227	247	267	287	304	321	344	367	390	412	438	464	
109	202	222	243	263	283	299	316	340	363	386	408	434	460	
105	197	218	238	258	278	295	311	335	359	382	405	431	456	

Table 7-20 Refrigerant charge for H/P system

MRB-48HWN1-M13C Heating Mode Mode De Chauffage		Heating Charge Chart/Tableau De Charge de Chauffage												
		Indoor Dry Bulb Temperature(F)/Temperature Interieur au Thermometre sec(en F)												
		60	62	64	66	68	70	72	74	76	78	80	82	
Low Pressure Detected Valve(psig) Vanne Détectée de Pression Basse(en psig)		High Pressure Detected Valve(psig)/Vanne Détecté de Pression Haute(en psig)												
		135	350	359	369	378	388	397	405	413	421	429	437	446
128	338	347	357	366	376	385	393	401	410	418	426	436		
121	326	335	345	354	364	373	381	390	398	406	415	424		
114	314	323	332	341	350	359	368	377	385	394	403	412		
107	301	310	319	329	338	347	355	363	371	379	387	395		
100	296	303	311	318	326	333	341	348	356	364	372	381		
93	285	292	299	307	314	321	328	335	342	349	356	365		
86	274	281	287	294	301	308	315	323	331	338	346	356		
79	263	269	275	282	288	294	302	311	319	328	336	345		
72	251	257	263	270	276	281	289	304	311	320	328	337		
65							281	297	304	312	319	327		
58								286	293	300	308	317		
51									282	289	296	304		
44										277	285	294		
37											274	283		
30														

Table 7-21 Refrigerant charge for A/C system

MRB-48CWN1-X13 Cooling Mode Mode De Refroidissement		Cooling Charge Chart/Tableau De Charge de Refroidissement													
		Outdoor Ambient Temperature(F)/Temperature Amdiante Exterieur(en F)													
		55	60	65	70	75	80	85	90	95	100	105	110	115	
		High Pressure Detected Valve(psig)/Vanne Détecté de Pression Haute(en psig)													
Low Pressure Detected Valve(psig)	Vanne Détectée de Pression Basse(en psig)	165			289	309	329	351	373	391	410	436	461	485	508
		161			286	306	326	348	369	388	406	432	457	481	505
		157			283	303	323	344	366	385	404	428	452	478	503
		153		260	280	300	320	341	362	381	400	425	449	475	500
		149		256	277	297	317	338	359	378	398	422	445	471	496
		145		253	274	294	314	335	355	375	395	419	442	466	490
		141		249	270	290	311	332	352	373	393	416	438	461	484
		137	233	245	266	286	307	328	348	369	390	411	432	456	480
		133	230	245	265	285	305	325	345	365	385	406	427	453	478
		129	227	246	265	284	303	322	341	360	379	402	424	450	476
		125	224	243	262	281	300	318	336	356	376	399	421	448	475
		121	220	239	258	277	296	314	331	352	372	396	419	446	472
		117	215	234	254	273	292	309	326	348	369	393	416	442	468
		113	207	227	247	267	287	304	321	344	367	390	412	438	464
		109	202	222	243	263	283	299	316	340	363	386	408	434	460
105	197	218	238	258	278	295	311	335	359	382	405	431	456		

Table 7-22 Refrigerant charge for H/P system

MRB-48HWN1-X13 Cooling Mode Mode De Refroidissement		Cooling Charge Chart/Tableau De Charge de Refroidissement													
		Outdoor Ambient Temperature(F)/Temperature Amdiante Exterieur(en F)													
		55	60	65	70	75	80	85	90	95	100	105	110	115	
		High Pressure Detected Valve(psig)/Vanne Détecté de Pression Haute(en psig)													
Low Pressure Detected Valve(psig)	Vanne Détectée de Pression Basse(en psig)	165			289	309	329	351	373	391	410	436	461	485	508
		161			286	306	326	348	369	388	406	432	457	481	505
		157			283	303	323	344	366	385	404	428	452	478	503
		153		260	280	300	320	341	362	381	400	425	449	475	500
		149		256	277	297	317	338	359	378	398	422	445	471	496
		145		253	274	294	314	335	355	375	395	419	442	466	490
		141		249	270	290	311	332	352	373	393	416	438	461	484
		137	233	245	266	286	307	328	348	369	390	411	432	456	480
		133	230	245	265	285	305	325	345	365	385	406	427	453	478
		129	227	246	265	284	303	322	341	360	379	402	424	450	476
		125	224	243	262	281	300	318	336	356	376	399	421	448	475
		121	220	239	258	277	296	314	331	352	372	396	419	446	472
		117	215	234	254	273	292	309	326	348	369	393	416	442	468
		113	207	227	247	267	287	304	321	344	367	390	412	438	464
		109	202	222	243	263	283	299	316	340	363	386	408	434	460
105	197	218	238	258	278	295	311	335	359	382	405	431	456		

Table 7-23 Refrigerant charge for H/P system

MRB-48HWN1-X13 Heating Mode Mode De Chauffage		Heating Charge Chart/Tableau De Charge de Chauffage													
		Indoor Dry Bulb Temperature(F)/Temperature Interieur au Themometre sec(en F)													
		60	62	64	66	68	70	72	74	76	78	80	82		
		High Pressure Detected Valve(psig)/Vanne Détecté de Pression Haute(en psig)													
Low Pressure Detected Valve(psig)	Vanne Détectée de Pression Basse(en psig)	135	350	359	369	378	388	397	405	413	421	429	437	446	
		128	338	347	357	366	376	385	393	401	410	418	426	436	
		121	326	335	345	354	364	373	381	390	398	406	415	424	
		114	314	323	332	341	350	359	368	377	385	394	403	412	
		107	301	310	319	329	338	347	355	363	371	379	387	395	
		100	296	303	311	318	326	333	341	348	356	364	372	381	
		93	285	292	299	307	314	321	328	335	342	349	356	365	
		86	274	281	287	294	301	308	315	323	331	338	346	356	
		79	263	269	275	282	288	294	302	311	319	328	336	345	
		72	251	257	263	270	276	281	289	304	311	320	328	337	
		65							281	297	304	312	319	327	
		58								286	293	300	308	317	
		51									282	289	296	304	
		44										277	285	294	
		37											274	283	
		30													

Table 7-24 Refrigerant charge for A/C system

MRB-60CWN1-M13 Cooling Mode Mode De Refroidissement		Cooling Charge Chart/Tableau De Charge de Refroidissement													
		Outdoor Ambient Temperature(F)/Temperature Amiante Exterieur(en F)													
		55	60	65	70	75	80	85	90	95	100	105	110	115	
Low Pressure Detected Valve(psig)	Vanne Déteéée de Pression Basse(en psig)	High Pressure Detected Valve(psig)/Vanne Déteéée de Pression Haute(en psig)													
		165			278	300	322	341	360	382	405	429	454	479	505
		161			276	297	319	338	357	379	402	427	453	477	502
		157			273	294	316	335	354	376	399	424	450	474	499
		153		246	270	292	315	334	352	374	396	422	448	472	496
		149		242	267	289	312	331	350	371	393	419	445	469	493
		145		239	264	286	309	328	348	369	390	416	442	466	490
		141	216	235	261	283	306	326	347	367	387	413	439	464	489
		137	214	231	258	280	305	325	345	365	384	410	437	462	487
		133	211	228	255	277	302	322	342	362	381	408	434	459	484
		129	209	224	252	274	299	319	339	359	379	405	431	456	482
		125	206	220	249	271	296	316	336	356	376	402	428	453	479
		121	204	217	247	268	293	313	334	353	373	399	425	451	477
		117	202	213	244	265	292	312	332	351	370	396	422	449	476
		113	199	210	241	263	289	309	329	348	367	393	419	446	473
109	197	206	238	260	286	306	326	345	364	390	416	444	471		
105	191	204	235	257	283	303	323	342	361	387	413	441	468		

Table 7-25 Refrigerant charge for H/P system

MRB-60HWN1-M13 Cooling Mode Mode De Refroidissement		Cooling Charge Chart/Tableau De Charge de Refroidissement													
		Outdoor Ambient Temperature(F)/Temperature Amiante Exterieur(en F)													
		55	60	65	70	75	80	85	90	95	100	105	110	115	
Low Pressure Detected Valve(psig)	Vanne Déteéée de Pression Basse(en psig)	High Pressure Detected Valve(psig)/Vanne Déteéée de Pression Haute(en psig)													
		165			278	300	322	341	360	382	405	429	454	479	505
		161			276	297	319	338	357	379	402	427	453	477	502
		157			273	294	316	335	354	376	399	424	450	474	499
		153		246	270	292	315	334	352	374	396	422	448	472	496
		149		242	267	289	312	331	350	371	393	419	445	469	493
		145		239	264	286	309	328	348	369	390	416	442	466	490
		141	216	235	261	283	306	326	347	367	387	413	439	464	489
		137	214	231	258	280	305	325	345	365	384	410	437	462	487
		133	211	228	255	277	302	322	342	362	381	408	434	459	484
		129	209	224	252	274	299	319	339	359	379	405	431	456	482
		125	206	220	249	271	296	316	336	356	376	402	428	453	479
		121	204	217	247	268	293	313	334	353	373	399	425	451	477
		117	202	213	244	265	292	312	332	351	370	396	422	449	476
		113	199	210	241	263	289	309	329	348	367	393	419	446	473
109	197	206	238	260	286	306	326	345	364	390	416	444	471		
105	191	204	235	257	283	303	323	342	361	387	413	441	468		

Table 7-26 Refrigerant charge for H/P system

MRB-60HWN1-M13 Heating Mode Mode De Chauffage		Heating Charge Chart/Tableau De Charge de Chauffage													
		Indoor Dry Bulb Temperature(F)/Temperature Interieur au Themometre sec(en F)													
		60	62	64	66	68	70	72	74	76	78	80	82		
Low Pressure Detected Valve(psig)	Vanne Déteéée de Pression Basse(en psig)	High Pressure Detected Valve(psig)/Vanne Déteéée de Pression Haute(en psig)													
		135	341	353	364	376	388	400	404	408	414	420	426	432	
		128	337	349	360	372	384	396	400	404	408	412	416	428	
		121	329	340	351	362	373	384	389	394	399	404	408	420	
		114	321	331	342	353	364	371	377	383	389	395	401	413	
		107	313	321	329	337	345	354	362	370	378	386	394	406	
		100	305	313	321	329	337	345	353	361	369	377	386	398	
		93	297	305	313	321	329	338	344	350	356	362	369	386	
		86	289	296	303	311	318	326	333	340	347	354	362	374	
		79	278	285	292	300	307	315	324	331	339	347	355	367	
		72	267	274	281	289	296	304	315	322	331	340	348	360	
		65	256	264	271	279	287	296	306	312	322	331	341	353	
		58							297	302	313	324	334	346	
		51								294	304	315	327	339	
		44									297	304	320	332	
37										296	313	325			
30											308	320			

Table 7-27 Refrigerant charge for A/C system

MRB-60CWN1-X13 Cooling Mode Mode De Refroidissement		Cooling Charge Chart/Tableau De Charge de Refroidissement													
		Outdoor Ambient Temperature(F)/Temperature Amdiante Exterieur(e)(en F)													
		55	60	65	70	75	80	85	90	95	100	105	110	115	
Low Pressure Detected Valve(psig) Vanne Détectée de Pression Basse(en psig)		High Pressure Detected Valve(psig)/Vanne Détecté de Pression Haute(en psig)													
		165			290	309	327	348	368	384	400	418	437	453	471
		161			287	305	323	344	364	380	396	414	432	449	467
		157			283	301	319	336	354	373	392	409	427	445	463
		153		262	280	298	316	333	350	368	386	404	421	439	457
		149		258	276	294	312	328	345	364	383	401	419	436	454
		145		253	271	289	307	325	342	360	379	396	414	432	450
		141	231	249	267	285	303	321	338	356	374	392	410	428	446
		137	228	246	264	282	300	317	334	352	370	388	406	423	441
		133	225	243	261	279	297	314	330	348	366	384	401	419	437
		129	222	240	258	276	294	310	326	344	362	379	397	415	433
		125	218	236	254	272	290	306	322	340	357	375	393	411	429
		121	214	232	250	268	286	302	318	336	353	371	389	407	425
		117	211	229	247	265	283	298	314	331	349	367	385	402	420
		113	207	225	243	261	279	294	310	327	345	363	380	398	416
		109	203	221	239	257	275	291	306	323	341	358	376	394	412
		105	200	218	236	254	272	287	302	319	336	354	372	390	408

Table 7-28 Refrigerant charge for H/P system

MRB-60HWN1-X13 Cooling Mode Mode De Refroidissement		Cooling Charge Chart/Tableau De Charge de Refroidissement													
		Outdoor Ambient Temperature(F)/Temperature Amdiante Exterieur(e)(en F)													
		55	60	65	70	75	80	85	90	95	100	105	110	115	
Low Pressure Detected Valve(psig) Vanne Détectée de Pression Basse(en psig)		High Pressure Detected Valve(psig)/Vanne Détecté de Pression Haute(en psig)													
		165			290	309	327	348	368	384	400	418	437	453	471
		161			287	305	323	344	364	380	396	414	432	449	467
		157			283	301	319	336	354	373	392	409	427	445	463
		153		262	280	298	316	333	350	368	386	404	421	439	457
		149		258	276	294	312	328	345	364	383	401	419	436	454
		145		253	271	289	307	325	342	360	379	396	414	432	450
		141	231	249	267	285	303	321	338	356	374	392	410	428	446
		137	228	246	264	282	300	317	334	352	370	388	406	423	441
		133	225	243	261	279	297	314	330	348	366	384	401	419	437
		129	222	240	258	276	294	310	326	344	362	379	397	415	433
		125	218	236	254	272	290	306	322	340	357	375	393	411	429
		121	214	232	250	268	286	302	318	336	353	371	389	407	425
		117	211	229	247	265	283	298	314	331	349	367	385	402	420
		113	207	225	243	261	279	294	310	327	345	363	380	398	416
		109	203	221	239	257	275	291	306	323	341	358	376	394	412
		105	200	218	236	254	272	287	302	319	336	354	372	390	408

Table 7-29 Refrigerant charge for H/P system

MRB-60HWN1-X13 Heating Mode Mode De Chauffage		Heating Charge Chart/Tableau De Charge de Chauffage													
		Indoor Dry Bulb Temperature(F)/Temperature Interieur au Themometre sec(en F)													
		60	62	64	66	68	70	72	74	76	78	80	82		
Low Pressure Detected Valve(psig) Vanne Détectée de Pression Basse(en psig)		High Pressure Detected Valve(psig)/Vanne Détecté de Pression Haute(en psig)													
		135	339	350	360	371	381	396	410	417	423	430	441	451	
		128	332	342	351	360	370	386	402	405	408	410	420	429	
		121	323	333	342	352	361	374	387	393	399	405	414	423	
		114	316	325	334	344	353	363	372	381	389	398	407	416	
		107	308	317	326	335	344	351	358	369	379	390	399	408	
		100	300	309	318	327	335	339	343	357	370	384	393	401	
		93	293	301	309	317	325	321	316	337	357	378	386	394	
		86	285	292	300	308	316	306	296	321	347	372	379	387	
		79	277	284	292	299	306	292	277	306	336	365	373	380	
		72	269	276	283	290	297	278	260	293	326	359	366	373	
		65	261	268	276	283	290	273	255	287	319	351	359	366	
		58							251	282	313	344	351	359	
		51								276	306	336	344	352	
		44									300	329	337	344	
		37										321	329	337	
		30											322	330	

8.0 SYSTEM OPERATION

8.1 COMPRESSOR CRANKCASE HEATER(FOR HP SYSTEM ONLY)

Refrigerant migration during the off cycle can result in a noisy start up. Add a crankcase heater to minimize refrigeration migration, and to help eliminate any start up noise or bearing "wash out".

All heaters are located on the lower half of the compressor shell. Its purpose is to drive refrigerant from the compressor shell during long off cycles, thus preventing damage to the compressor during start-up.

At initial start-up or after extended shutdown periods, make sure the heater is energized for at least 12 hours before the compressor is started. (Disconnect switch on and wall thermostat off.)

The crankcase heater start-up conditions:

If the outdoor ambient temp. is $<37.4^{\circ}\text{F}$ and the compressor stopped for more than three hours or the unit powered on once more, the crank heater will be on.

Crankcase heater shut-down conditions:

If the outdoor ambient temp. is $>44.6^{\circ}\text{F}$ or the compressor start running ,the crank heater will be off.

8.2 Protection

8.2.1 Protection for AC system

Discharge temperature protection (for the unit which adopt Toshiba compressor):

When discharge temp. is $>275^{\circ}\text{F}$,the compressor will be off,

When discharge temp. is $<194^{\circ}\text{F}$,the compressor will start running.

High pressure protection (for the unit which adopt Toshiba compressor)

When high pressure is $>638\text{PSIG}$,the compressor and the outdoor fan motor will stop running.

When high pressure is $<464\text{PSIG}$,the compressor and the outdoor fan motor will start running(3 minutes delay necessary).

Low pressure protection (for the unit which adopt Toshiba compressor)

When low pressure is $<21\text{PSIG}$,the compressor and the outdoor fan motor will stop running.

When low pressure is $>44\text{PSIG}$,the compressor and the outdoor fan motor will start running(3 minutes delay necessary).

In stand-by status, if low pressure protection was checked out, the compressor would not start running.

If protection cycles occur four times within 30 mins, the system must power on once more.

8.2.2 Protection for HP system

When the sensor(T3&T4) was checked open-circuit or short-circuit, the compressor ,outdoor fan motor and 4-way valve will be off.

Discharge temperature protection:

When discharge temp. is $>275^{\circ}\text{F}$,the compressor will be off, When discharge temp. is $<194^{\circ}\text{F}$,the compressor will start running.

High pressure protection

When high pressure is >638PSIG, the compressor and the outdoor fan motor will stop running.

When high pressure is <464PSIG, the compressor and the outdoor fan motor will start running(3 minutes delay necessary).

Low pressure protection

When low pressure is <21PSIG, the compressor and the outdoor fan motor will stop running.

When low pressure is >44PSIG, the compressor and the outdoor fan motor will start running(3 minutes delay necessary).

In stand-by status, if low pressure protection was checked out, the compressor would not start running.

If protection cycles occur four times within 30 mins, the system must power on once more.

T4 function:

When T4 is < 5 °F, the compressor will stop. If the electrical heater kit is installed in the indoor unit, the outdoor unit will send the operation signal to the indoor unit.

When T4 is > 10.4 °F, the compressor will restart

8.3 DEFROST MODE* (For HP system only)

Defrosting condition:

When JUMP switch is set to "1", the defrost mode will start if one of following conditions is satisfied:

1. Compressor keeps running, when T4 is > 28.4 °F and T3 is < 32 °F and last for 40 minutes;
2. Compressor keeps running, when T4 is < 28.4 °F and T3 is < 32 °F and last for 50 minutes.

* When defrosting actions, if the electrical heater kit is installed, the unit would deliver the Aux. heater operation signal to the electrical heater kit.

When JUMP switch is set to "0":

Compressor keeps running, when T3 is < 32 °F and last for 30 minutes.

Ending conditions of defrost mode:

The mode will end if one of following conditions is satisfied:

1. The defrosted time lasting for 10 minutes;
2. When JUMP switch is set to "1", T3 is $\geq 64.4^{\circ}\text{F}$;
3. When JUMP switch is set to "0", T3 is $\geq 77^{\circ}\text{F}$.

8.4 MANUAL DEFROST MODE (For HP system only)

When MANUAL DEFROST switch in PCB is set to "1", system will perform as above 8.3 description.

When the switch is set to "0", $T3 < 32^{\circ}\text{F}$, compressor keeps running and lasting for 40 seconds, the system turns to the Defrost Mode. By the logic of 8.3 to exit the Defrost Mode.

Caution: Once finishes the manual defrost, please switch the MANUAL DEFROST in PCB to "1".

8.5 THERMOSTAT SIGNALS

Table 8-1: Thermostat Signals

Table 8-1: Thermostat Signals

Signal	State	Board Function
G	ON	Blower instant ON
	OFF	Blower 90 sec. delay OFF
G & W1	ON	Blower instant ON Heater bank 1 elec.onstant ON
	OFF	Heater bank 1 elec.instant OFF Blower 90 sec. delay OFF
G & W & W2	ON	Blower instant ON Heater 1 instant ON Heater 2 instant ON
	OFF	Blower 90 sec. delay OFF Heater 1 instant OFF Heater 2 instant OFF
G & Y	ON	Blower instant ON Compressor and outdoor fan instant ON
	OFF	Compressor and outdoor fan instant OFF Blower fan delay 90 sec. OFF
G & B & Y	ON	Blower instant ON Compressor and outdoor fan instant ON 4-way valve instant ON
	OFF	Compressor and outdoor fan instant OFF Blower fan delay 90 sec. OFF 4-way valve instant OFF
G & B & Y & W1	ON	Blower instant ON Compressor and outdoor fan instant ON 4-way valve instant ON Heater 1 instant ON
	OFF	Blower fan delay 90 sec. OFF Compressor and outdoor fan instant OFF 4-way valve instant OFF Heater 1 instant OFF
G & B & Y & W1 & W2	ON	Blower instant ON Compressor and outdoor fan instant ON 4-way valve instant ON Heater 1 instant ON Heater 2 instant ON
	OFF	Blower fan delay 90 sec. OFF Compressor and outdoor fan instant OFF 4-way valve instant OFF Heater 1 instant OFF Heater 2 instant OFF

9.0 OPERATION CHECK-UP

- **Cooling Startup**

1. Turn thermostat to OFF and turn power to ON
2. Turn ON thermostat and set as high as possible
3. Turn Fan switch ON and indoor blower should run
4. Turn fan switch to AUTO, system switch to COOL and thermostat temperature setting below room temperature.
Unit should run in COOLING mode.

- **Heating Startup**

After normal cooling run

1. Turn thermostat switch to HEAT. After unit stops, wait about 5 minutes.
2. Turn thermostat setting above room temperature.
Unit should run in HEATING mode.

After unit has run for a while, check the following:

1. Are fans running properly?
2. Is compressor running correctly?
3. Check refrigerant charge.
4. Check duct connection and leaks.
5. Check tubing and sheet metal rattles.

(See Wiring Diagram for electric connection detail.)

10.0 TROUBLE SHOOTING



WARNING

Components trouble shooting requires opening control box with power on. Use extreme care while working on this condition. Check nameplate and this instruction when making wire connections.

AC System Wiring Diagram (Single Phase)

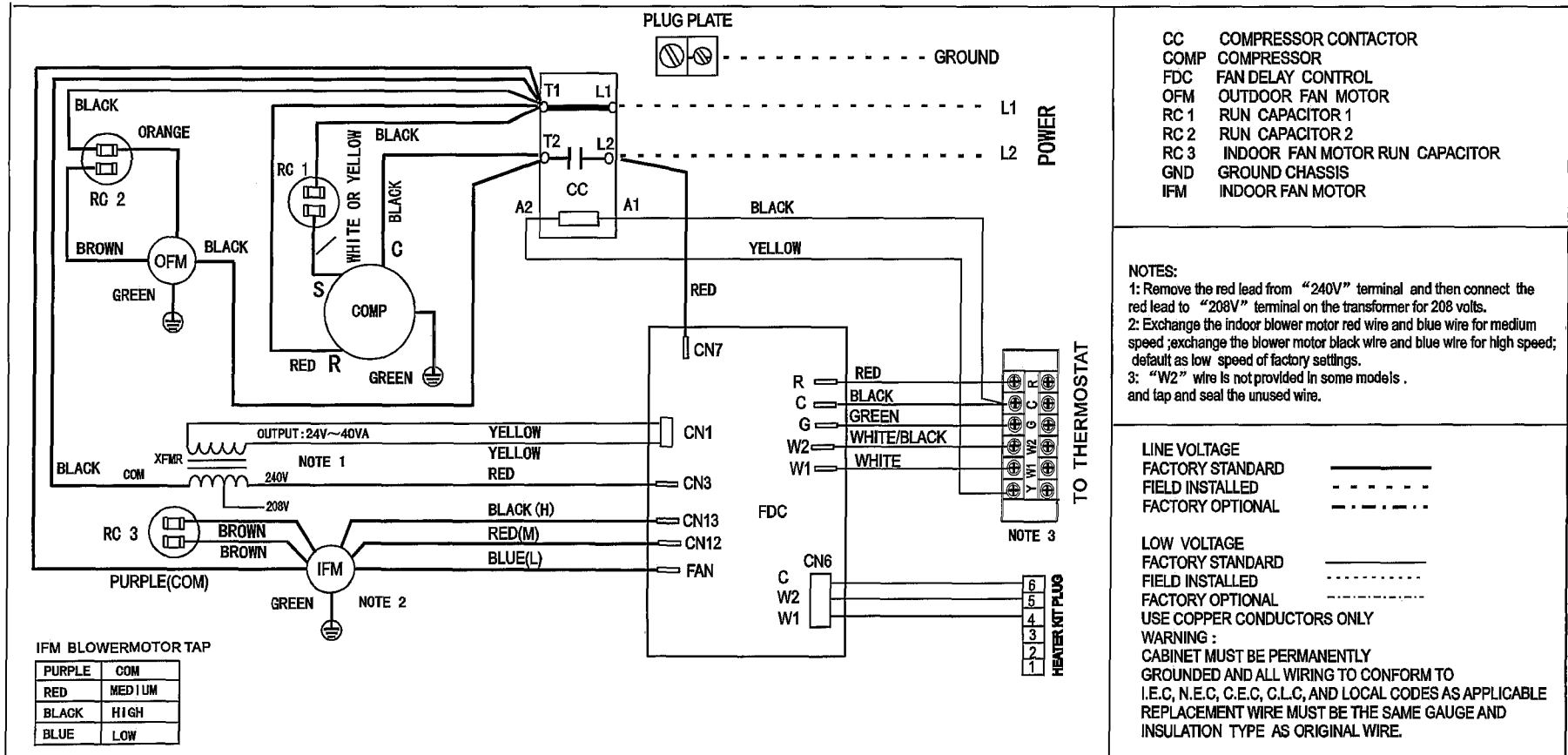

HP System Wiring Diagram (Single Phase):

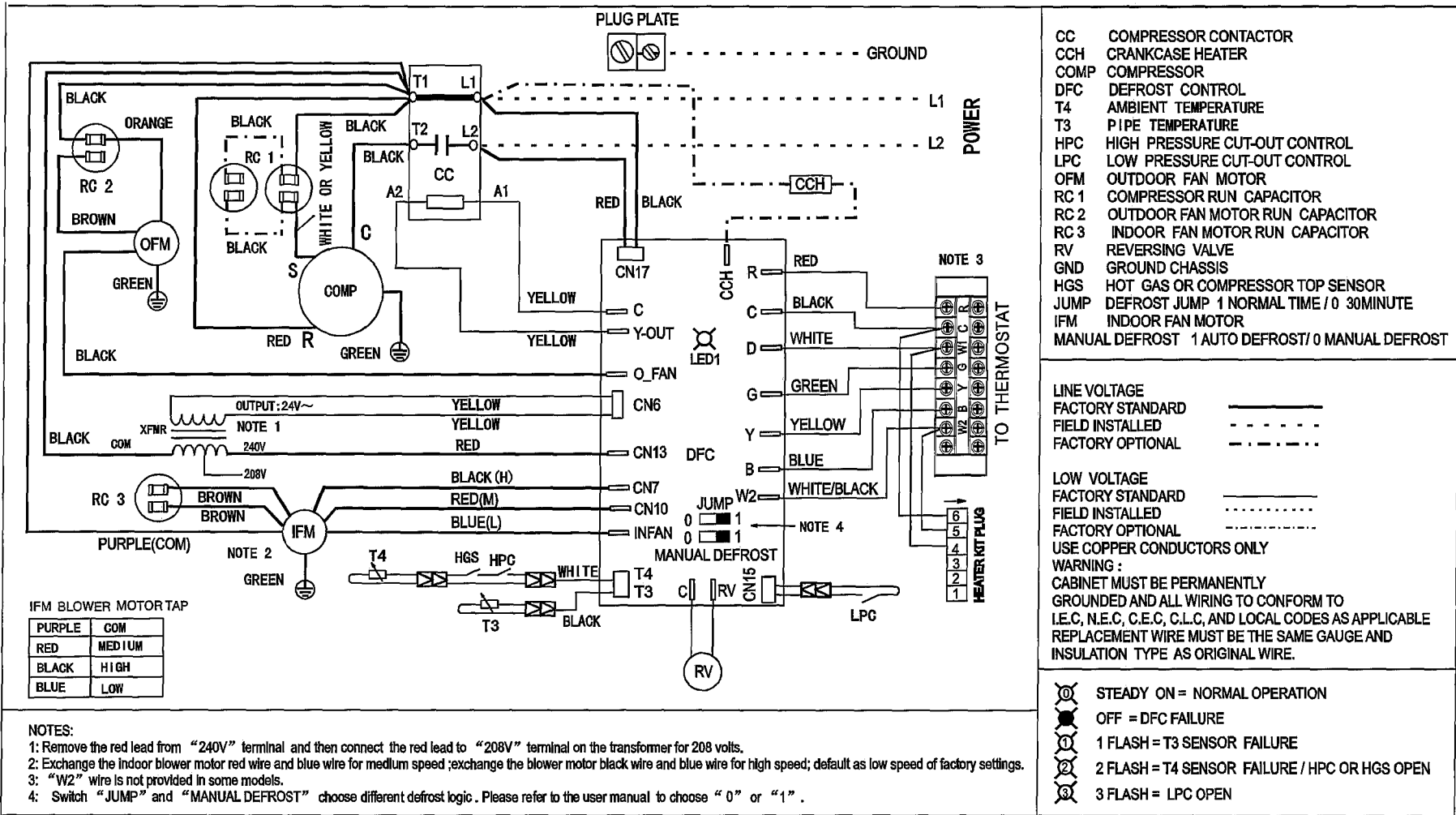

AC System Wiring Diagram (Three Phase)

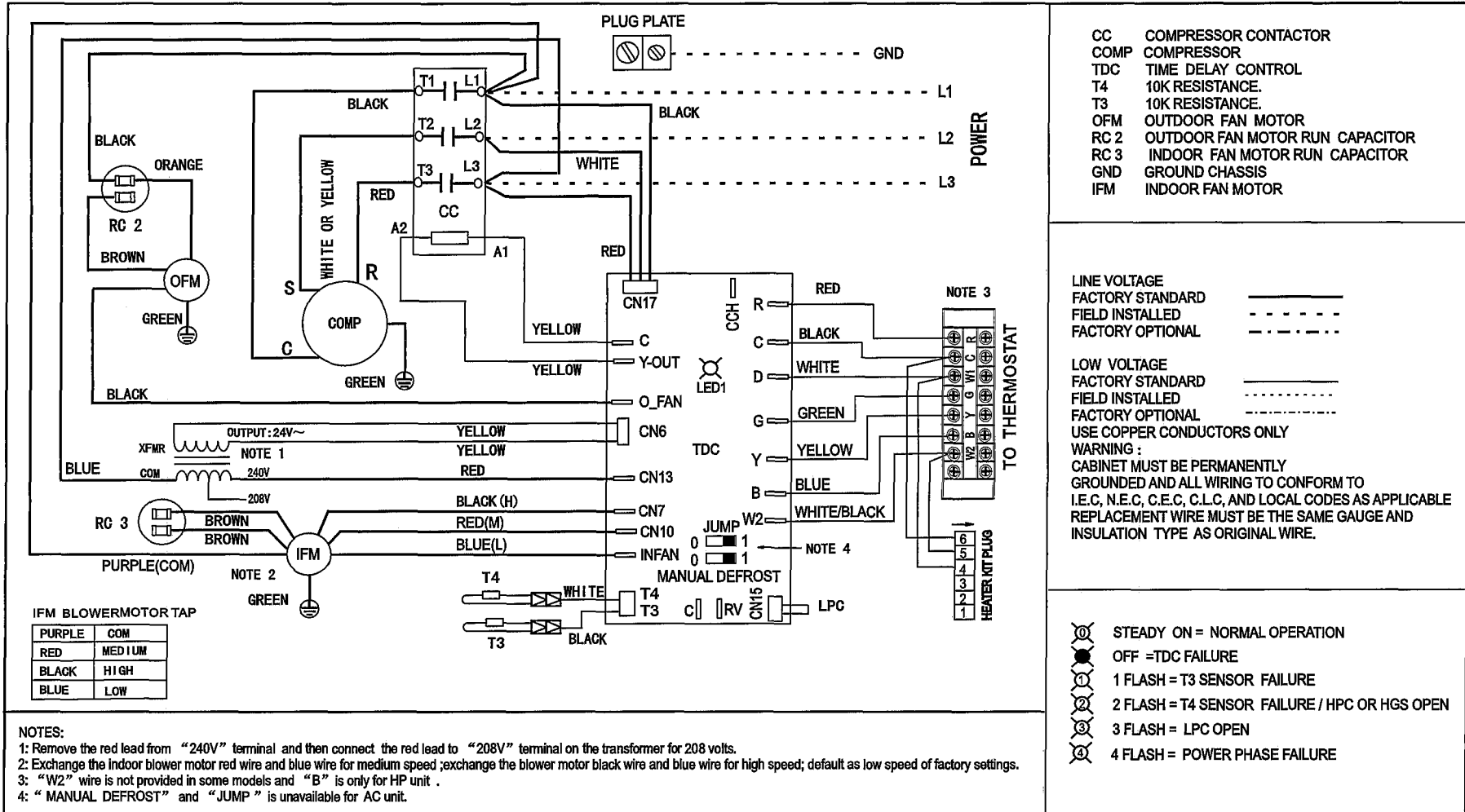

HP System Wiring Diagram (Three Phase)

