

Submittal Data: MEH-12NIH

DC inverter 15 SEER 12,000 Btu/h Wall Mounted Ductless Heat Pump System

Job Name: \_\_\_\_\_ Location: \_\_\_\_\_ Date: \_\_\_\_\_

Purchaser: \_\_\_\_\_ Engineer: \_\_\_\_\_

Submitted To: \_\_\_\_\_ For: \_\_\_\_\_ Review( ) Approval ( )

**DIMENSION:**

Indoor Model No. MEH-12NIH

**Neola Basic Series**  
 1 Ton Heat Pump Air Handler  
 115v

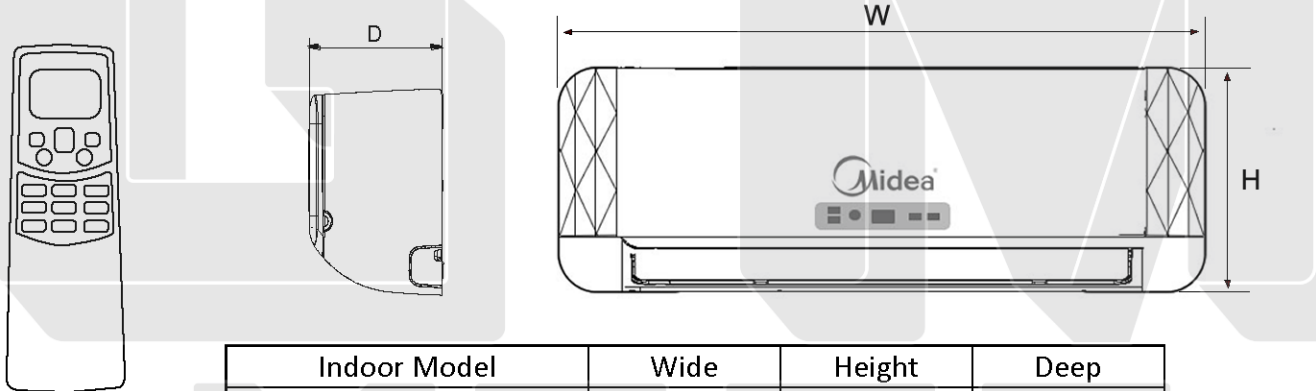

Indoor Model	Wide	Height	Deep
MEH-12NIH	30 1/4"	10"	7 1/4"

Air Handler Controller

**Outdoor Units**

**Neola Basic Series**  
 1 Ton Heat Pump Air Handler  
 115v

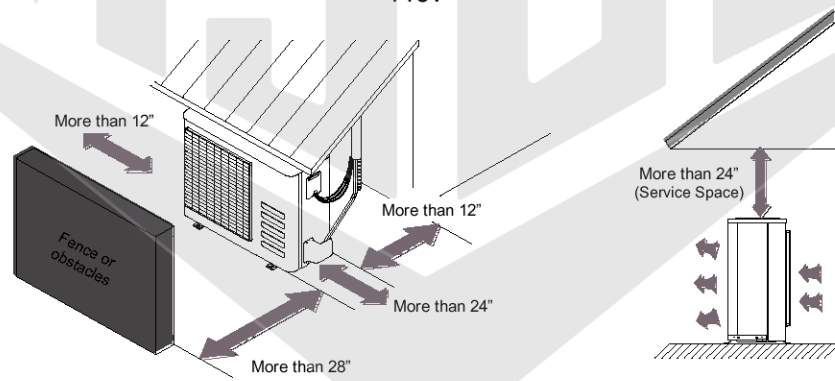

## Neola Basic Series

1 Ton Heat Pump Condenser  
 115v

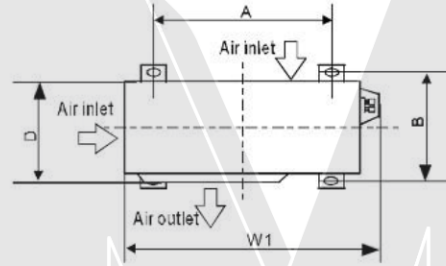
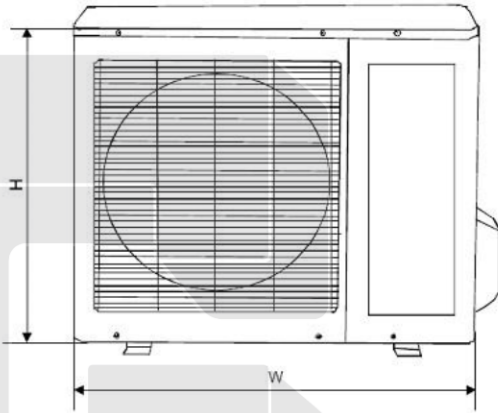

Outdoor Model	W	H	D	W1	A	B
MCH-12NIH	26"	21"	10"	28.81"	18"	10.86"

The pipe length and refrigerant amount:

Model	Pipe size		Standard length (ft)	Max. Elevation B (ft)	Max. Length A (ft)
	Gas	Liquid			
MCH-12NIH	1/2"	1/4"	15'	25'	60'

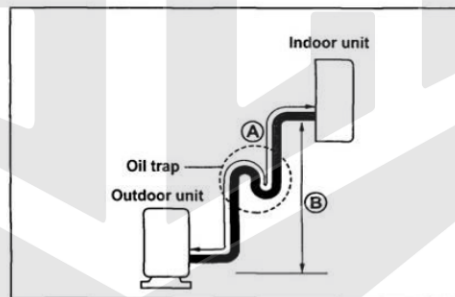
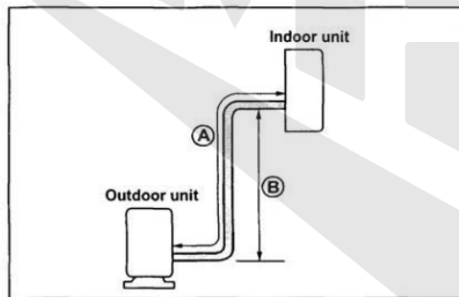

The oil trap should be installed per 15-21 feet.



# General Metals MFG & Supply CO.

2727 W. Weldon Ave. Phoenix, AZ  
 Email: [gminfo@generalmetals.com](mailto:gminfo@generalmetals.com)  
 Website: [www.generalmetals.com](http://www.generalmetals.com)  
 Phone: 602.264.4815



## Neola Basic Series

1 Ton Heat Pump Condenser  
 115v

### OPERATION CHARACTERISTICS

Temperature Mode	Cooling operation	Cooling Operation	Heating Operation
Room temperature	> (62°F)	> (50°F)	≤ (86°F)
Outdoor temperature	Factory built in low ambient kit		
	(5°F ~ 122°F) (For the models with (low temperature cooling system)	(32°F ~ 122°F)	(5°F ~ 86°F)

### GENERAL SPECIFICATIONS

- \*Power Supply : 115v
- \*SEER Rating: 15.0 EER 9.0
- \*HSPF: 8.2
- \*Cooling Capacity: 12,600 (2,600-13,500) Btu/h \*Heating Capacity: 12,000 (2,800-15,500) Btu/h
- \*Cooling Amps: 11.9 / Heating Amps: 11.7
- \*Breaker Size: 30 Amp-minimum circuit 20 Amp
- \*Controls: Wireless remote control
- \*Indoor Temperature Control Range: 62 °F - 86°F
- \*Operating Temperature Ranges: Cooling (32°F ~ 122°F), Heating (5°F ~ 86°F).
- \*Indoor Noise Level: 39/25/29 dB(A)
- \*Outdoor Noise Level: 55 dB(A)

### GENERAL FEATURES

- \* Limited Warranty: 1 year on parts & 5 years on compressor
- \* Eco-friendly R410a refrigerant with rotary TOSHIBA compressor
- \* Turbo Mode And Sleep Mode.
- \* Ultra-Quiet Operation
- \* Random swing , airflow direction control
- \* Self-Diagnostics, LCD display
- \* Auto restart operation
- \* Louver Memory Function.
- \* Timer
- \* Golden Fin Coils
- \* 3D Air Flow
- \* Low Ambient Cooling
- \* 46 F Heating
- \* 2 way drain connection
- \* Self cleaning
- \* Sleep Mode

