



TABLE of CONTENTS

	PAGE
INTRODUCTION.....	1
MODEL / SERIAL NUMBER NOMENCLATURES	2
SPECIFICATIONS - HEAT PUMP	3
DIMENSIONS AND WEIGHTS	4
CLEARANCES.....	7
ELECTRICAL DATA	8
WIRING.....	8
CONNECTION DIAGRAMS	9
WIRING DIAGRAMS.....	10
FAN AND MOTOR SPECIFICATIONS.....	14
REFRIGERATION CYCLE DIAGRAMS.....	15
REFRIGERANT LINES.....	20
SYSTEM EVACUATION AND CHARGING.....	21
ELECTRONIC FUNCTIONS	22
POINT CHECK FUNCTION	27
TROUBLESHOOTING.....	28
INDOOR UNIT DIAGNOSTIC GUIDES.....	29
DIAGNOSIS AND SOLUTION.....	30
DISASSEMBLY INSTRUCTIONS	63

Installing, starting up, and servicing air-conditioning equipment can be hazardous due to system pressures, electrical components, and equipment location (roofs, elevated structures, etc.).

Only trained, qualified installers and service mechanics should install, start-up, and service this equipment.

Untrained personnel can perform basic maintenance functions such as coil cleaning. All other operations should be performed by trained service personnel.

When working on the equipment, observe precautions in the literature and on tags, stickers, and labels attached to the equipment.

Follow all safety codes. Wear safety glasses and work gloves. Keep a quenching cloth and fire extinguisher nearby when brazing. Use care in handling, rigging, and setting bulky equipment.

Read this manual thoroughly and follow all warnings or cautions included in the literature and attached to the unit. Consult local building codes and National Electrical Code (NEC) for special requirements. Recognize safety information. This is the safety-alert symbol . When you see this symbol on the unit and in instructions or manuals, be alert to the potential for personal injury.

Understand these signal words: **DANGER**, **WARNING**, and **CAUTION**. These words are used with the safety-alert symbol.

DANGER identifies the most serious hazards which **will** result in severe personal injury or death. **WARNING** signifies hazards which **could** result in personal injury or death. **CAUTION** is used to identify unsafe practices which **may** result in minor personal injury or product and property damage. **NOTE** is used to highlight suggestions which **will** result in enhanced installation, reliability, or operation.

 **WARNING**

ELECTRICAL SHOCK HAZARD

Failure to follow this warning could result in personal injury or death.

Before installing, modifying, or servicing system, main electrical disconnect switch must be in the **OFF** position. There may be more than 1 disconnect switch. Lock out and tag switch with a suitable warning label.

 **WARNING**

EXPLOSION HAZARD

Failure to follow this warning could result in death, serious personal injury, and/or property damage. Never use air or gases containing oxygen for leak testing or operating refrigerant compressors.

Pressurized mixtures of air or gases containing oxygen can lead to an explosion.



 **CAUTION**

EQUIPMENT DAMAGE HAZARD

Failure to follow this caution may result in equipment damage or improper operation. Do not bury more than 36 in. (914 mm) of refrigerant pipe in the ground. If any section of pipe is buried, there must be a 6 in. (152 mm) vertical rise to the valve connections on the outdoor units.

If more than the recommended length is buried, refrigerant may migrate to the cooler buried section during extended periods of system shutdown. This causes refrigerant slugging and could possibly damage the compressor at start-up.

INTRODUCTION

This service manual provides the necessary information to service, repair, and maintain the **DLCSRB** family of heat pumps. Section 2 of this manual has an appendix with data required to perform troubleshooting. Use the “TABLE of CONTENTS” to locate a desired topic.

MODEL / SERIAL NUMBER NOMENCLATURES

Table 1 —Unit Sizes

SYSTEM TONS	kBTUh	VOLTAGE	OUTDOOR MODEL
1.00	12,000	115-1-60	DLCSRBH12AAJ
0.75	9,000	208/230-1	DLCSRBH09AAK
1.00	12,000		DLCSRBH12AAK
1.50	18,000		DLCSRBH18AAK
2.00	24,000		DLCSRBH24AAK

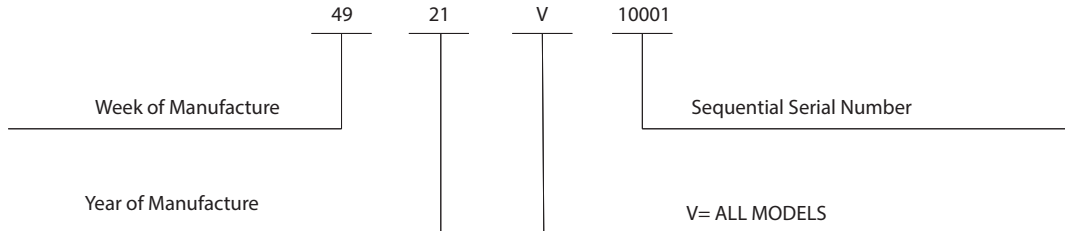
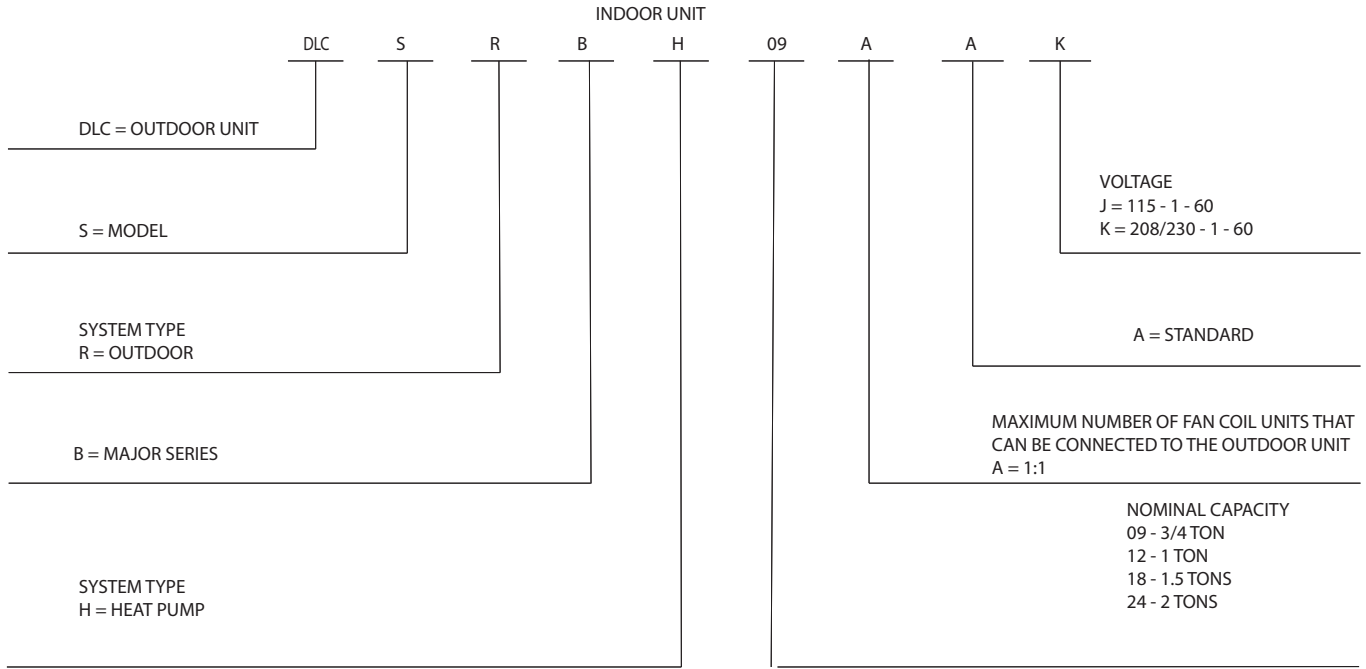

Use of the AHRI Certified TM Mark indicates a manufacturer's participation in the program. For verification of certification for individual products, go to www.ahridirectory.org.



SPECIFICATIONS - HEAT PUMP

Table 2 — Specifications

System	Size		12	9	12	18	24
	Outdoor Model		DLCSRBH12AAJ	DLCSRBH09AAK	DLCSRBH12AAK	DLCSRBH18AAK	DLCSRBH24AAK
Electrical	Voltage, Phase, Cycle	V/Ph/Hz	115-1-60	208/230-1-60	208/230-1-60	208/230-1-60	208/230-1-60
	MCA	A.	19	15	15	16	25
	MOCF - Fuse Rating	A.	25	15	15	25	35
Operating Range	Cooling Outdoor DB Min - Max	°F(°C)	-22~130 (30-55)	-22~130 (30-55)	-22~130 (30-55)	-22~130 (30-55)	-22~130 (30-55)
	Heating Outdoor DB Min - Max	°F(°C)	-22~86 (-30~30)	-22~86 (-30~30)	-22~86 (-30~30)	-22~86 (-30~30)	-22~86 (-30~30)
Piping	Total Piping Length	ft (m)	82 (25)	82 (25)	82 (25)	98 (30)	164 (50)
	Piping Lift	ft (m)	32 (10)	32 (10)	32 (10)	65 (20)	82 (25)
	Pipe Connection Size - Liquid	in (mm)	1/4 (6.35)	1/4 (6.35)	1/4 (6.35)	1/4 (6.35)	3/8 (9.52)
	Pipe Connection Size - Suction	in (mm)	1/2 (12.7)	3/8 (9.52)	1/2 (12.7)	1/2 (12.7)	5/8 (16)
Refrigerant	Refrigerant Type		R410A	R410A	R410A	R410A	R410A
	Charge	lbs (kg)	2.47 (1.12)	2.6 (1.18)	2.6 (1.18)	4.08 (1.85)	5.73 (2.6)
	Metering Device		EEV	EEV	EEV	EEV	EEV
Outdoor Coil	Face Area	Sq. Ft.	7.89	4.67	4.67	5.90	8.16
	No. Rows		2	2	2	2	2
	Fins per inch		21	20	20	20	20
	Circuits		4	4	4	6	4
Compressor	Type		Rotary Inverter	Rotary Inverter	Rotary Inverter	Rotary Inverter	Rotary Inverter
	Model		KSK103D33UEZ3	KTN110D42UFZ	KTN110D42UFZ	KTM240D43UKT	KTM240D43UKT
	Oil Type		VG74	VG74	VG74	VG74	VG74
	Oil Charge	Fl. Oz.	10.5	11.8	11.8	21.0	21.0
	Rated Current	RLA	11.5	6.0	8.5	14.3	14.8
Outdoor	Unit Width	in (mm)	30.12 (765)	31.69 (805)	31.69 (805)	35.04 (890)	37.24 (946)
	Unit Height	in (mm)	21.85 (555)	21.81 (554)	21.81 (554)	26.50 (673)	31.89 (810)
	Unit Depth	in (mm)	11.93 (303)	12.99 (330)	12.99 (330)	13.46 (342)	16.14 (410)
	Net Weight	lbs (kg)	66.80 (30.3)	74.07 (33.6)	73.63 (33.4)	100.97 (45.8)	134.48 (61)
	Airflow	CFM	794	1,324	1,324	1,765	2,235
Sound Pressure	dB(A)	54.0	54.5	56.0	59.0	62.0	

* Condensing unit above or below the indoor unit

DIMENSIONS AND WEIGHTS

Table 3 — Dimensions and Weights

SYSTEM SIZE			12K	9K	12K	18K	24K	
			(115 V)	(208/230 V)	(208/230 V)	(208/230 V)	(208/230 V)	
OUTDOOR UNIT	UNIT							
	Height (H)	in (mm)	21.85 (555)	21.81 (554)	21.81 (554)	26.50 (673)	31.89 (810)	
	Width (W)	in (mm)	30.12 (765)	31.69 (805)	31.69 (805)	35.04 (890)	37.24 (946)	
	Depth (D)	in (mm)	11.93 (303)	12.99 (330)	12.99 (330)	13.46 (342)	16.14 (410)	
	Weight - Net	lbs. (kg)	66.80 (30.3)	74.07 (33.6)	73.63 (33.4)	100.97 (45.8)	134.48 (61)	
	PACKAGING							
	Height	in (mm)	24.02 (610)	24.21(615)	24.21 (615)	29.13 (740)	34.84 (885)	
	Width	in (mm)	34.92 (887)	36.02 (915)	36.02 (915)	39.17 (995)	42.91 (1090)	
	Depth	in (mm)	13.27 (337)	14.57 (370)	14.57 (370)	15.67 (398)	19.69 (500)	
	Weight -Gross	lbs. (kg)	72.31 (32.8)	80.25 (36.4)	79.37 (36)	108.03 (49)	144.40 (65.5)	
	Carton Drawing No.	--	877*327*590	905*360*590	905*360*590	985*388*720	1075*485*86	
	CARTON MATERIAL							
	Material Thickness	in (mm)	0.197 (5)	0.197 (5)	0.197 (5)	0.197 (5)	0.295 (7.5)	

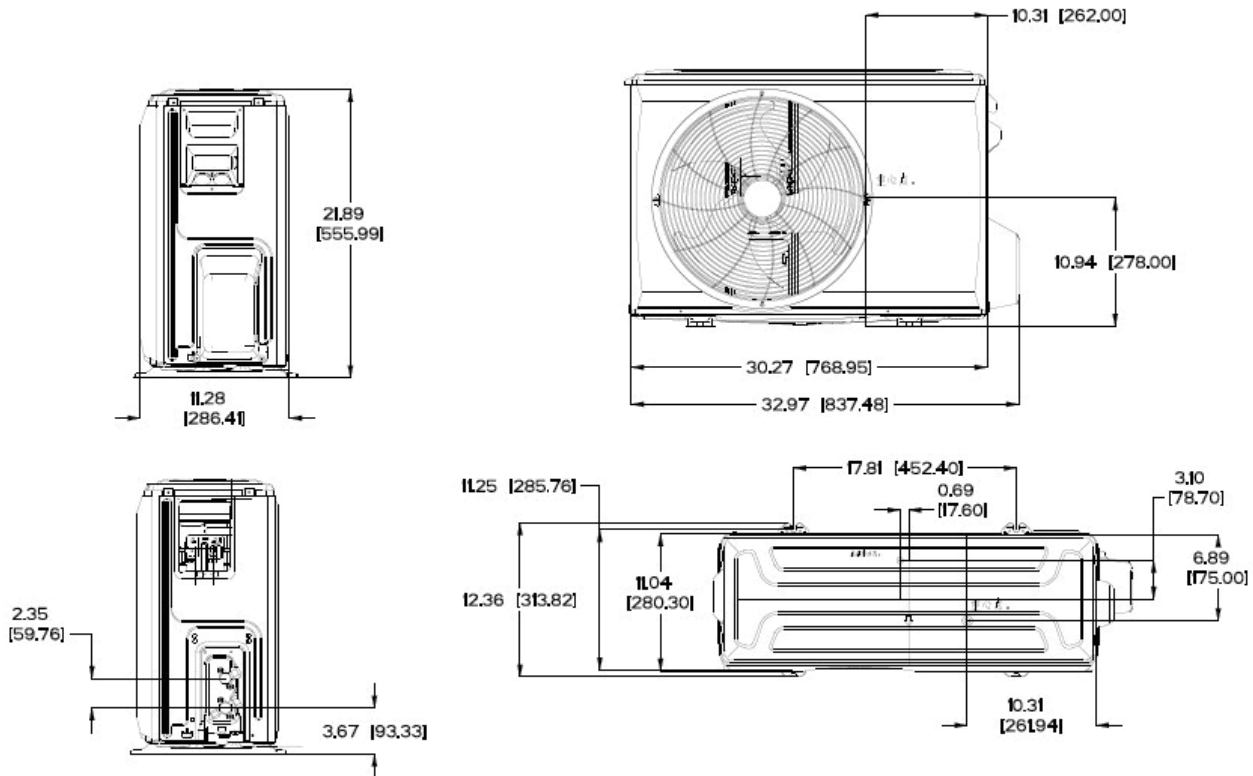

Fig. 1 — Size 12K (115V)

DIMENSIONS AND WEIGHTS (CONT)

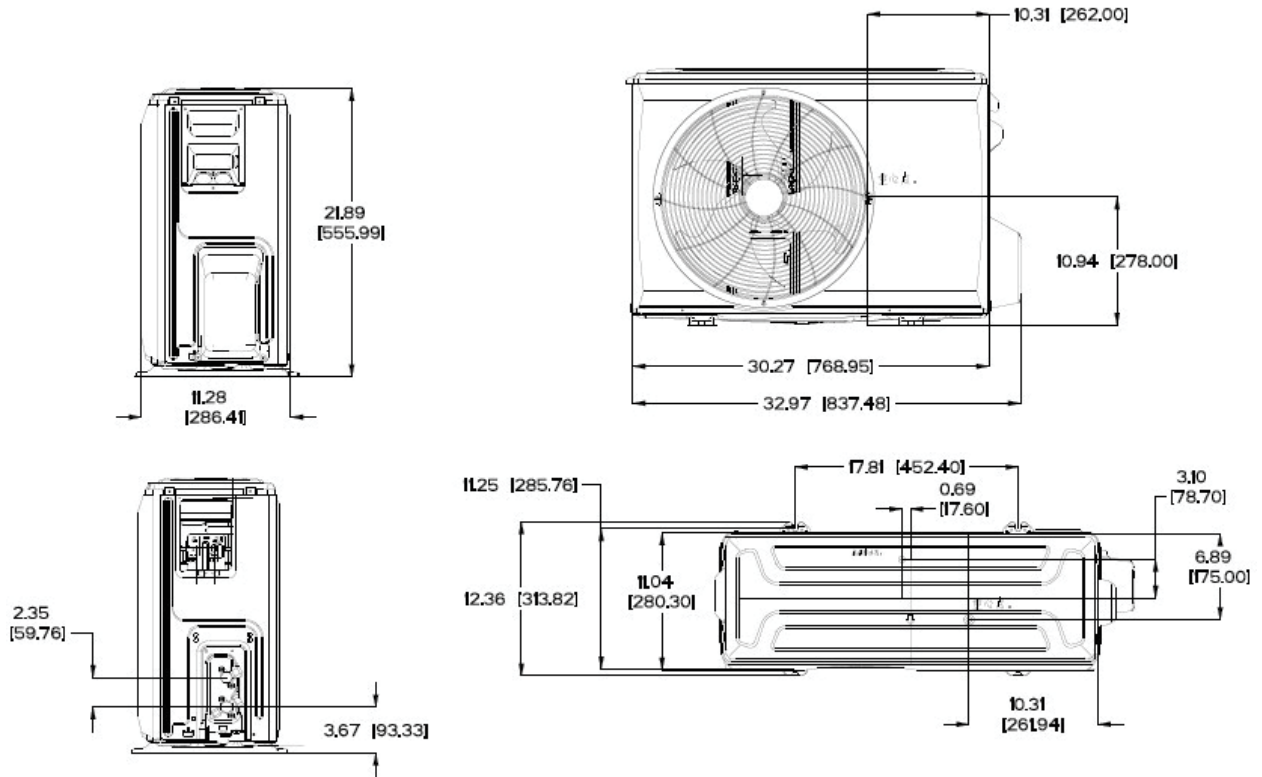

Fig. 2 — Dimension Sizes 9K-12K (208/230V)

DIMENSIONS AND WEIGHTS (CONT)

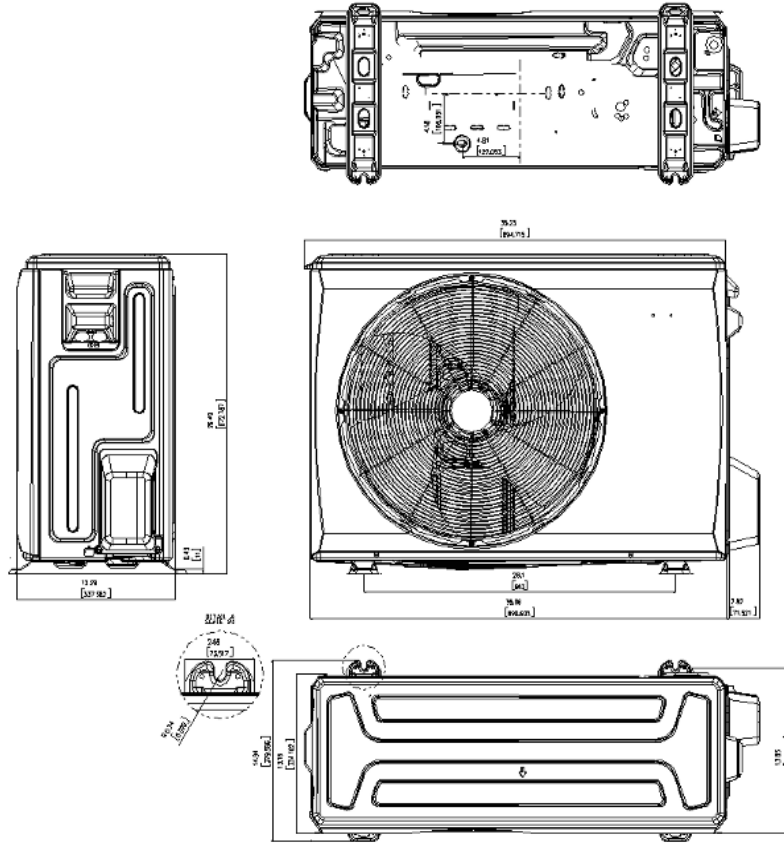

Fig. 3 — Size 18K (208/230V)

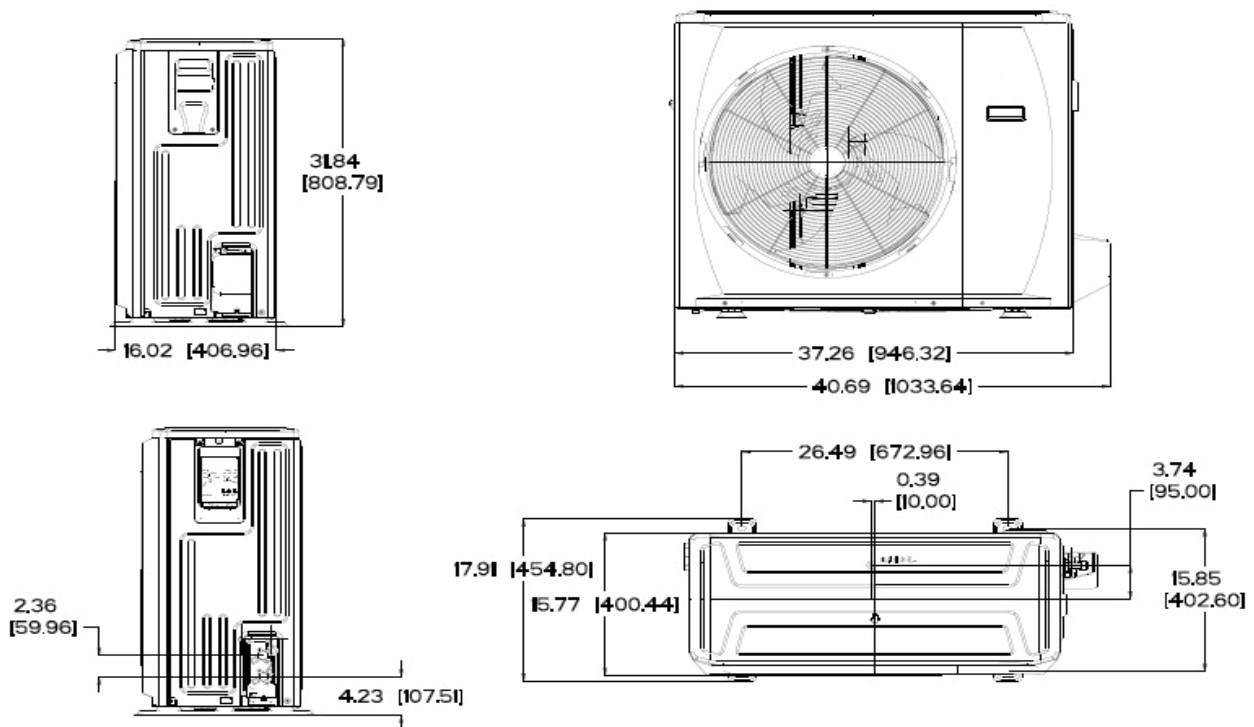

Fig. 4 — Size 24K (208/230V)

CLEARANCES

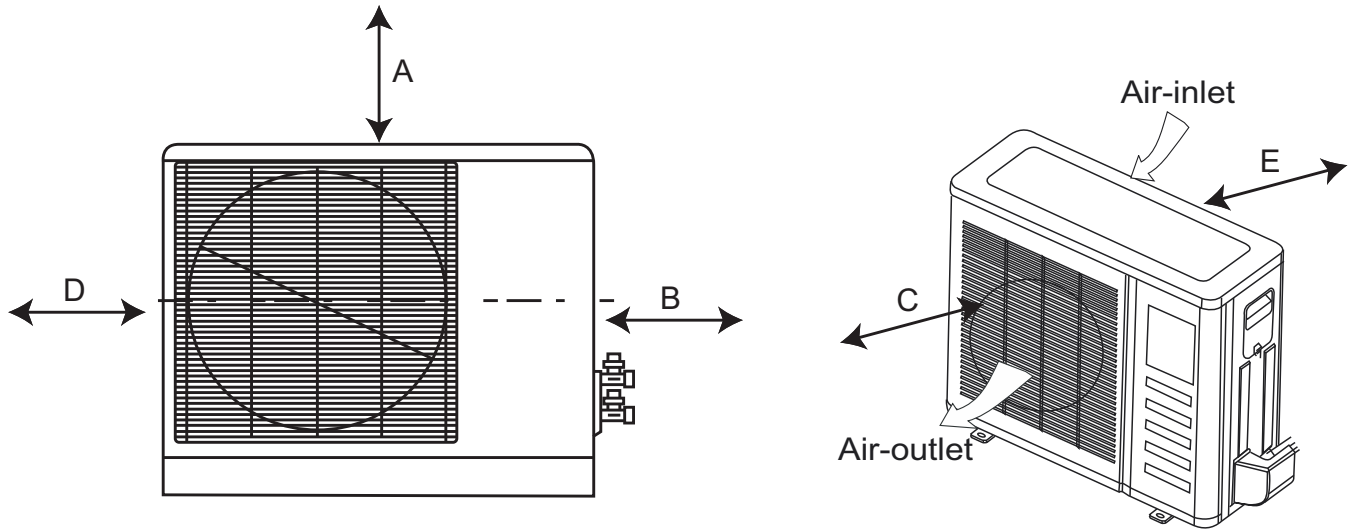

Fig. 5 — Clearances

Table 4 — Clearances

UNIT	MINIMUM VALUE IN. (MM)
A	24 (609)
B	24 (609)
C	24 (609)
D	4 (101)
E	4 (101)

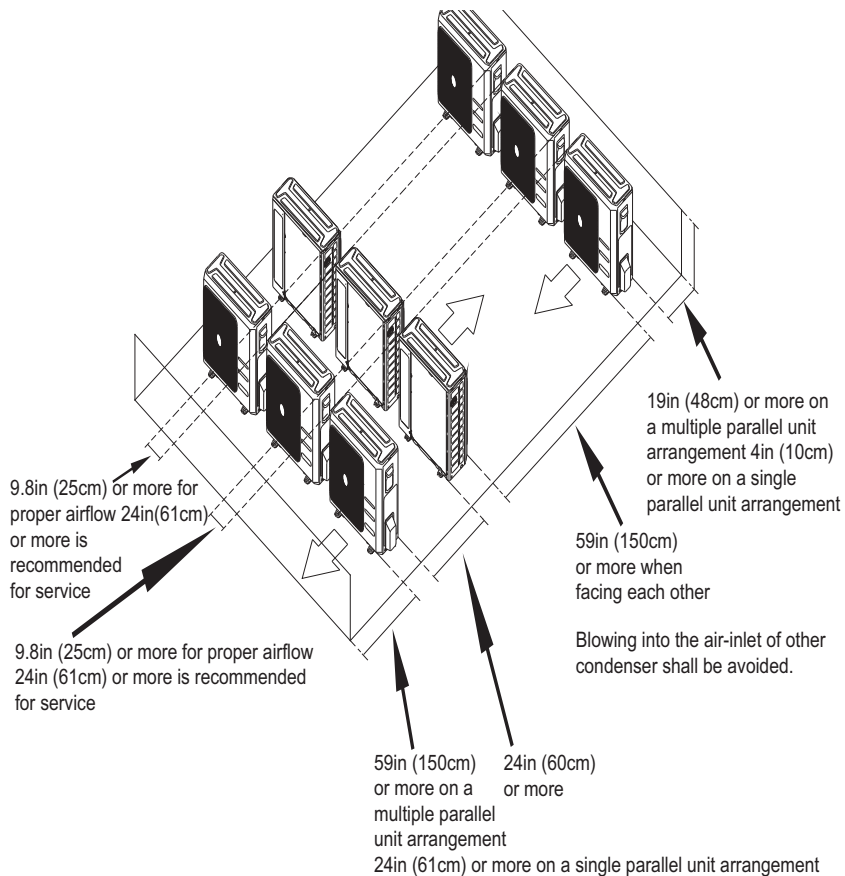

Fig. 6 — Clearances for multiple units

ELECTRICAL DATA

Table 5 — Electrical Data

SYSTEM SIZE		12K	9K	12K	18K	24K
POWER SUPPLY	Volts-PH-Hz	115-1-60	208/230-1-60	208/230-1-60	208/230-1-60	208/230-1-60
	Max – Min*Oper. Voltage	127-104	253-187	253-187	253-187	253-187
	MCA	19	15	15	16	25
	Recommended Fuse Size (in A.)	20	15	15	20	25
	Max Fuse/CB AMP	25	15	15	25	35
COMPRESSOR	Volts-PH-Hz	115-1-60	208/230-1-60	208/230-1-60	208/230-1-60	208/230-1-60
	RLA	11.5	6.0	8.5	14.25	14.8

*Permissible limits of the voltage range at which the unit operates satisfactorily.

LEGEND:

FLA - Full Load Amps

MCA - Minimum Circuit Amps

RLA - Rated Load Amps

WIRING

All wires must be sized per NEC (National Electrical Code) or CEC (Canadian Electrical Code) and local codes. Use Electrical Data table MCA (minimum circuit amps) and MOCP (maximum over current protection) to correctly size the wires and the disconnect fuse or breakers respectively.

Recommended Connection Method for Power and Communication Wiring:

The main power is supplied to the outdoor unit. The field supplied 14/3 power/communication wiring, from the outdoor unit to the indoor unit, consists of four (4) wires and provides the power for the indoor unit. Two wires are high voltage AC power, one is communication wiring and the other is a ground wire. Wiring between indoor and outdoor unit is polarity sensitive. The use of BX wire is NOT recommended.

If installed in a high Electromagnetic field (EMF) area and communication issues exists, a 14/2 stranded shielded wire can be used to replace L2 and (S) between outdoor unit and indoor unit landing the shield onto ground in the outdoor unit only.

 **CAUTION**

EQUIPMENT DAMAGE HAZARD

Failure to follow this caution may result in equipment damage or improper operation.

Wires should be sized based on NEC and local codes.

 **CAUTION**

EQUIPMENT DAMAGE HAZARD

Failure to follow this caution may result in equipment damage or improper operation.

Be sure to comply with local codes while running wire from the indoor unit to the outdoor unit.

Every wire must be connected firmly. Loose wiring may cause the terminal to overheat or result in unit malfunction. A fire hazard may also exist. Ensure all wiring is tightly connected.

No wire should touch the refrigerant tubing, compressor or any moving parts.

Disconnecting means must be provided and shall be located within sight and readily accessible from the air conditioner.

Connecting cable with conduit shall be routed through the hole in the conduit panel.

NOTE: Matches with multi-family and residential fan coils require separate power for the indoor and outdoor unit. A 24V interface kit is required for compatibility. Refer to the 24V Interface Kit installation manual.

CONNECTION DIAGRAMS

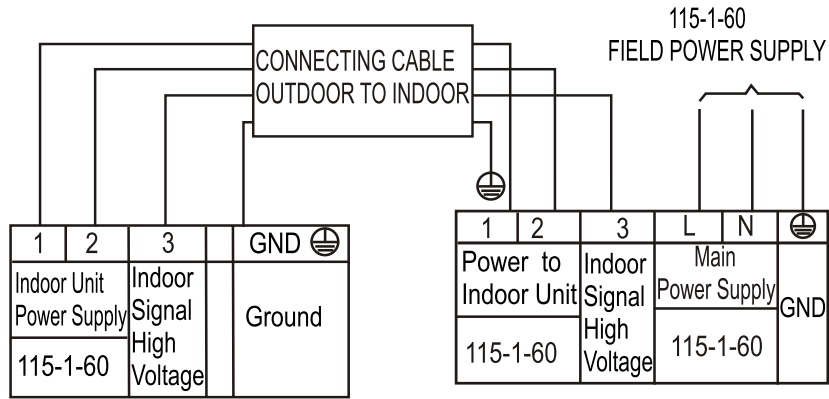

Fig. 7 — Connection Diagram 12K (115 V)

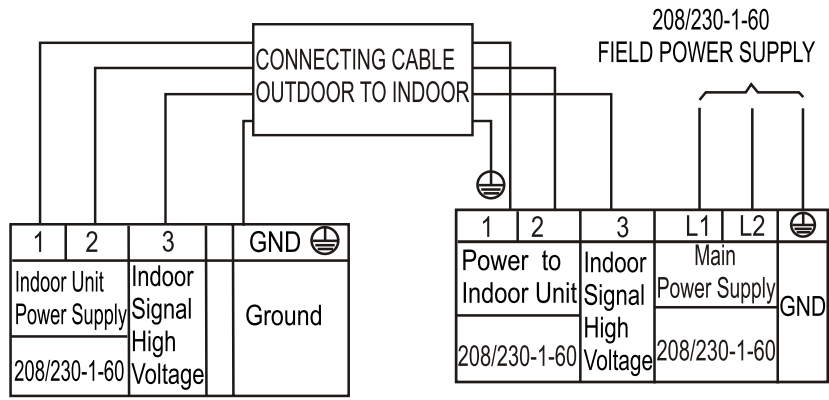

Fig. 8 — Connection Diagram - Sizes 9K-12K (208/230-1-60 V)

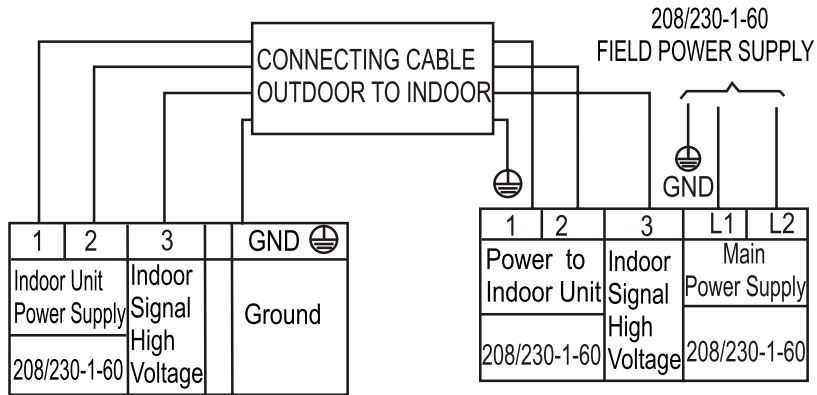

Fig. 9 — Connection Diagram - Size 24K (208/230-1-60 V)

NOTES:

1. Do not use thermostat wire for any connection between indoor and outdoor units.
2. All connections between indoor and outdoor units must be as shown in Figures 7 - 9. The connections are sensitive to polarity and will result in a fault code.

WIRING DIAGRAMS

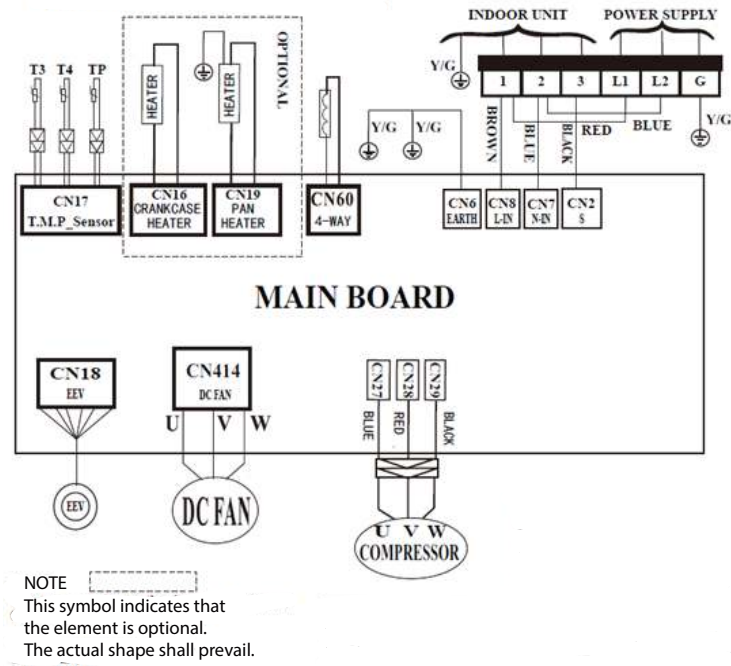

Fig. 10 — Wiring Diagram - Size 12K (115V)

Table 6 — Wiring Diagram - Size 12K (115V)

CN2/7/8	Input	230V	AC
CN18	Output	0~12V	DC
CN414	Output	0~310V	AC
CN60	Output	230V	AC
CN17	Output	0~5V	DC
CN16	Output	230V	AC
CN19	Output	230V	AC
CN27/28/29	Output	0~310V	AC

Table 7 — Wiring Diagram - Size 12K (115V)

T3	Condenser Temperature Sensor
T4	Ambient Temperature Sensor
TP	Discharge Temperature Sensor

WIRING DIAGRAMS (CONT)

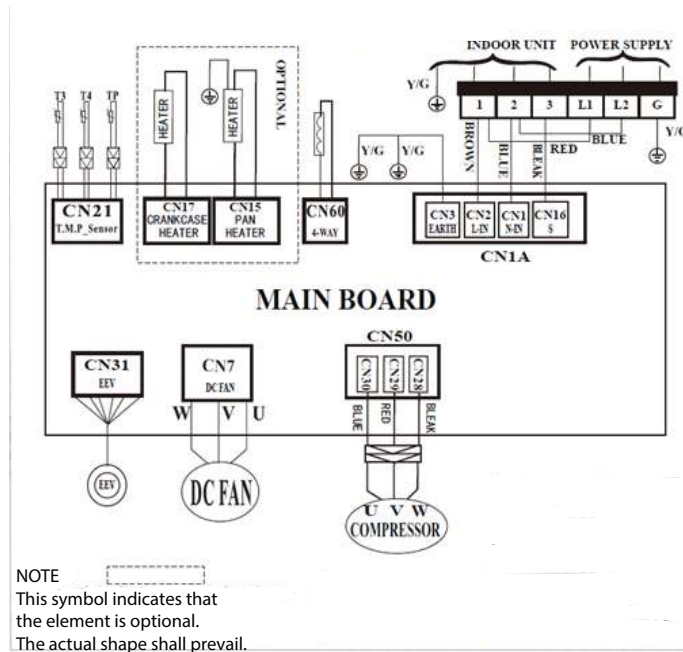

Fig. 11 — Wiring Diagram - Sizes 9K - 12K (208/230V)

Table 8 — Wiring Diagram - Sizes 9K - 12K (208/230V)

CN1A	Input	230V	AC
CN31	Output	0~12V	DC
CN7	Output	0~310V	AC
CN60	Output	230V	AC
CN21	Output	0~5V	DC
CN15	Output	230V	AC
CN17	Output	230V	AC
CN50	Output	0~310V	AC

Table 9 — Wiring Diagram - Sizes 9K - 12K (208/230V)

T3	Condenser Temperature Sensor
T4	Ambient Temperature Sensor
TP	Discharge Temperature Sensor

WIRING DIAGRAMS (CONT)

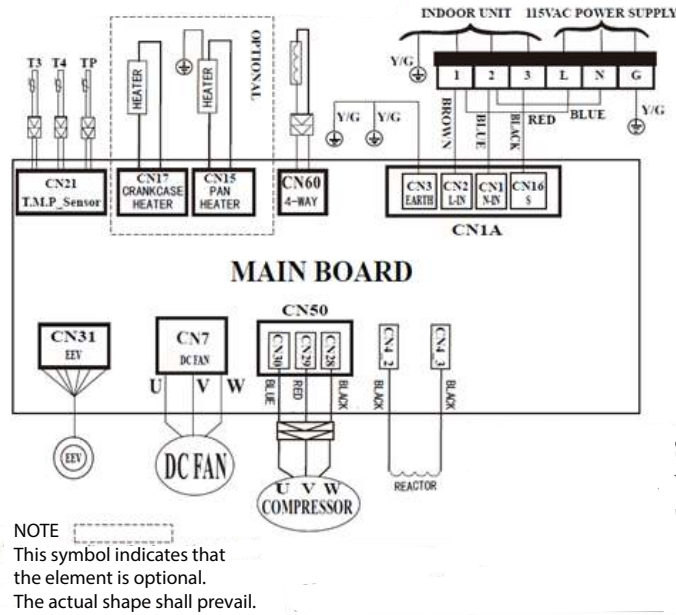

Fig. 12 — Wiring Diagram - Size 18K (208/230V)

Table 10 — Wiring Diagram - Size 18K (208/230V)

CN1A	Input	115V	AC
CN4_2/4_3	Input	115V	AC
CN7	Output	0~210V	AC
CN60	Output	115V	AC
CN21	Output	0~5V	DC
CN31	Output	0~12V	DC
CN15	Output	115V	AC
CN17	Output	115V	AC
CN50	Output	0~310V	AC

Table 11 — Wiring Diagram - Size 18K (208/230V)

T3	Condenser Temperature Sensor
T4	Ambient Temperature Sensor
TP	Discharge Temperature Sensor

WIRING DIAGRAMS (CONT)

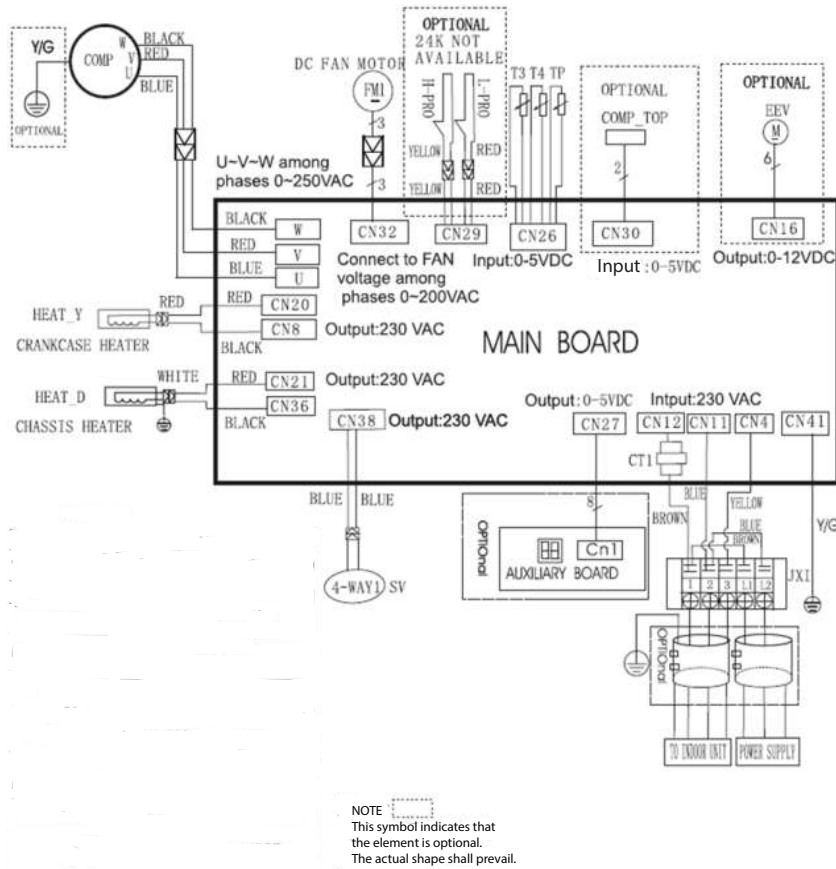

Fig. 13 — Wiring Diagram - Size 24K (208/230V)

Table 12 — Wiring Diagram - Size 24K (208/230V)

CODE	PART NAME
JX1	Terminal Block
COMP_TOP	Compressor Top OLP Temperature Sensor
EEV	Electronic Expansion Valve
FM1	DC Fan Motor
COMP	Compressor
HEAT_Y	Crankcase Heater
CT1	AC Current Detector
H-PRO	High Pressure Switch
L-PRO	Low Pressure Switch
SV	Reverse Valve
TP	COMP. Discharge Temperature Sensor
T3	Coil Temperature Sensor
T4	Outdoor Ambient Temperature Sensor
HEAT_D	Chassis Heater

FAN AND MOTOR SPECIFICATIONS

Table 13 — Fan and Motor Specifications

SYSTEM	SIZE		12	9	12	18	24
	OUTDOOR MODEL		DLCSRBH12AAJ	DLCSRBH09AAK	DLCSRBH12AAK	DLCSRBH18AAK	DLCSRBH24AAK
Electrical	Voltage, Phase, Cycle	V/Ph/Hz	115-1-60	208/230-1-60	208/230-1-60	208/230-1-60	208/230-1-60
	MCA	A.	19	15	15	16	25
	Recommended Fuse Size:	(in A.)	20	15	15	20	25
	MOCP - Fuse Rating	A.	25	15	15	25	35
Operating Range	Cooling Outdoor DB Min - Max	°F(°C)	-22~130 (30-55)	-22~130 (30-55)	-22~130 (30-55)	-22~130 (30-55)	-22~130 (30-55)
	Heating Outdoor DB Min - Max	°F(°C)	-22~86 (-30~30)	-22~86 (-30~30)	-22~86 (-30~30)	-22~86 (-30~30)	-22~86 (-30~30)
Piping	Total Piping Length	ft (m)	82 (25)	82 (25)	82 (25)	98 (30)	164 (50)
	Piping Lift*	ft (m)	32 (10)	32 (10)	32 (10)	65 (20)	82 (25)
	Pipe Connection Size - Liquid	in (mm)	1/4 (6.35)	1/4 (6.35)	1/4 (6.35)	1/4 (6.35)	3/8 (9.52)
	Pipe Connection Size - Suction	in (mm)	1/2 (12.7)	3/8 (9.52)	1/2 (12.7)	1/2 (12.7)	5/8 (16)
Refrigerant	Refrigerant Type		R410A	R410A	R410A	R410A	R410A
	Charge	lbs (kg)	2.47 (1.12)	2.6 (1.18)	2.6 (1.18)	4.08 (1.85)	5.73 (2.6)
	Metering Device		EEV	EEV	EEV	EEV	EEV
Outdoor Coil	Face Area	Sq. Ft.	7.89	4.67	4.67	5.90	8.16
	No. Rows		2	2	2	2	2
	Fins per inch		21	20	20	20	20
	Circuits		4	4	4	6	4
Compressor	Type		Rotary Inverter	Rotary Inverter	Rotary Inverter	Rotary Inverter	Rotary Inverter
	Model		KSK103D33UEZ3	KTN110D42UFZ	KTN110D42UFZ	KTM240D43UKT	KTM240D43UKT
	Oil Type		VG74	VG74	VG74	VG74	VG74
	Oil Charge	Fl. Oz.	10.5	11.8	11.8	21.0	21.0
	Rated Current	RLA	11.5	6.0	8.5	14.3	14.8
Outdoor	Unit Width	in (mm)	30.12 (765)	31.69 (805)	31.69 (805)	35.04 (890)	37.24 (946)
	Unit Height	in (mm)	21.85 (555)	21.81 (554)	21.81 (554)	26.50 (673)	31.89 (810)
	Unit Depth	in (mm)	11.93 (303)	12.99 (330)	12.99 (330)	13.46 (342)	16.14 (410)
	Net Weight	lbs (kg)	66.80 (30.3)	74.07 (33.6)	73.63 (33.4)	100.97 (45.8)	134.48 (61)
	Airflow	CFM	794	1,324	1,324	1,765	2,235
	Sound Pressure	dB(A)	54.0	54.5	56.0	59.0	62.0

REFRIGERATION CYCLE DIAGRAMS

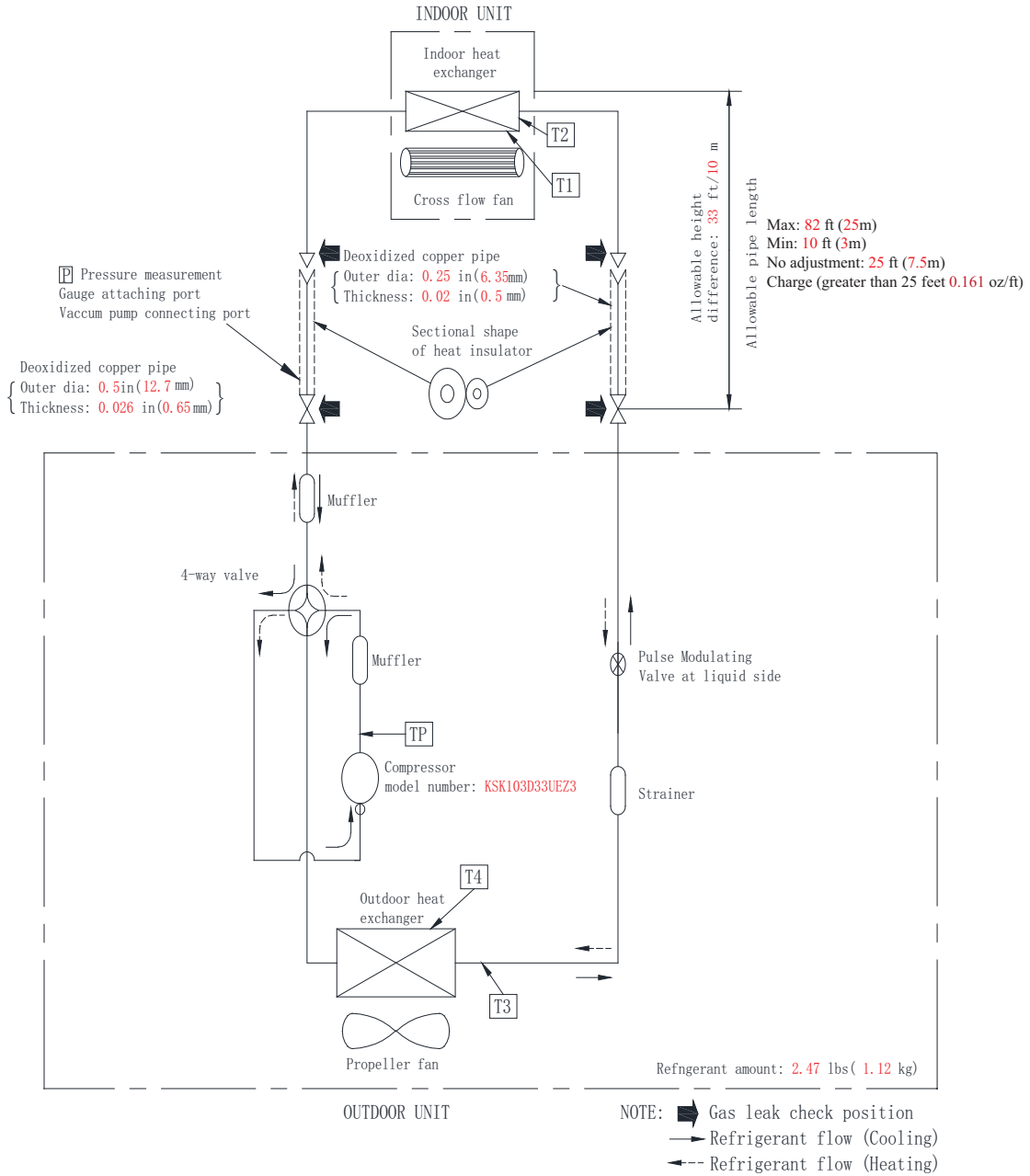

Fig. 14 — Refrigerant Cycle Diagram - Size 12K (115V)

REFRIGERATION CYCLE DIAGRAMS (CONT)

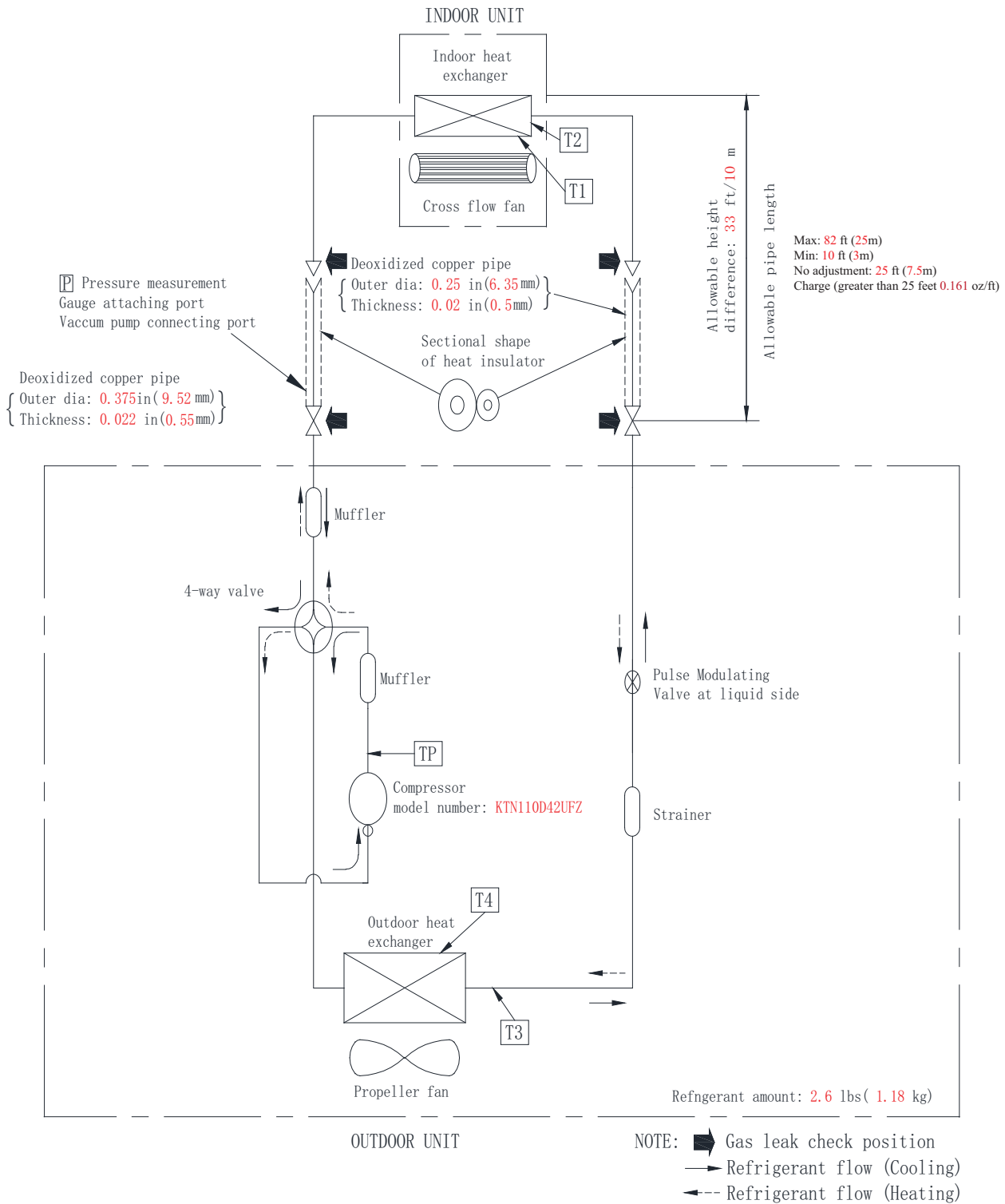

Fig. 15 — Refrigerant Cycle Diagram - Size 9K (208/230V)

REFRIGERATION CYCLE DIAGRAMS (CONT)

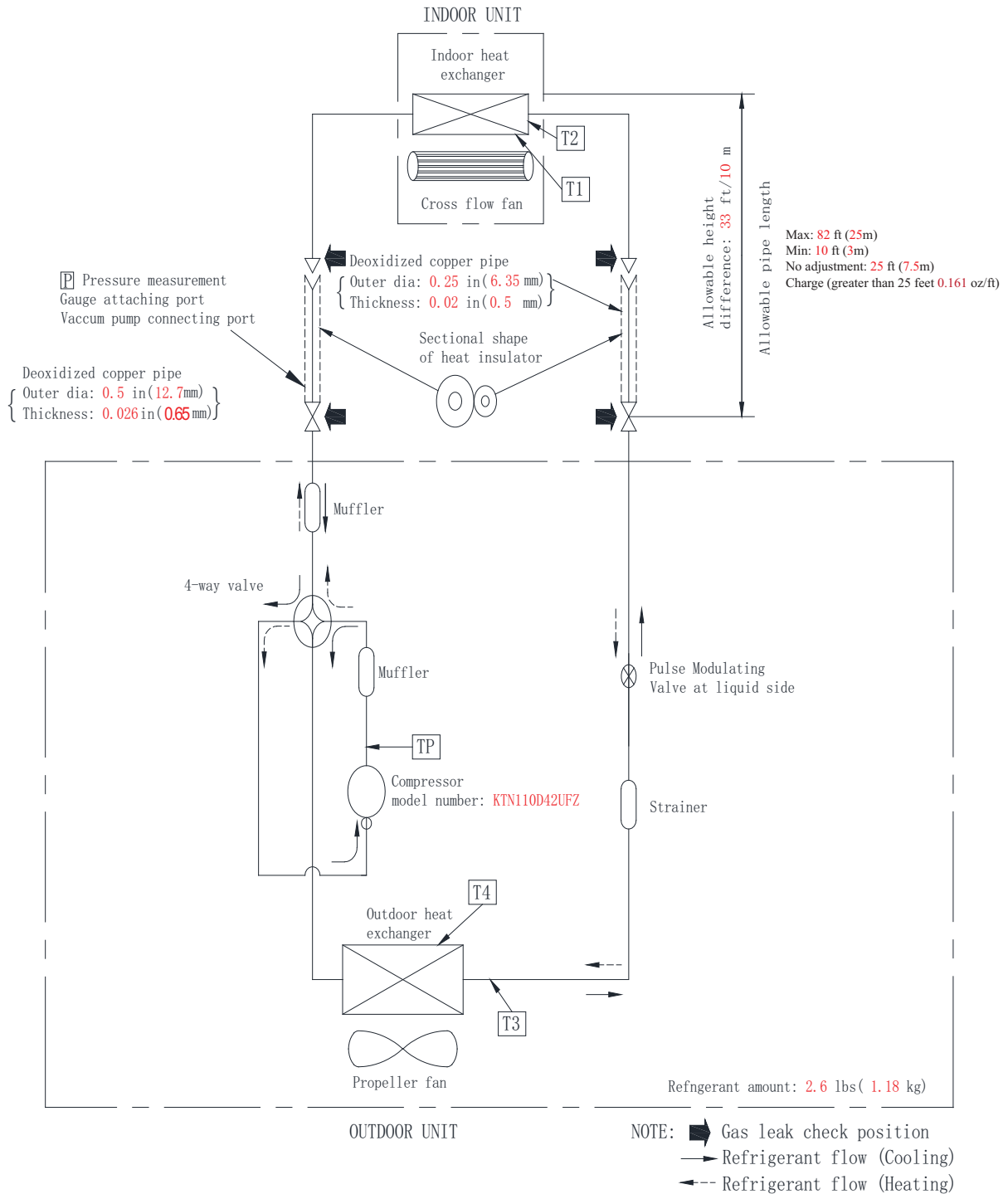

Fig. 16 — Refrigerant Cycle Diagram - Size 12K (208/230V)

REFRIGERATION CYCLE DIAGRAMS (CONT)

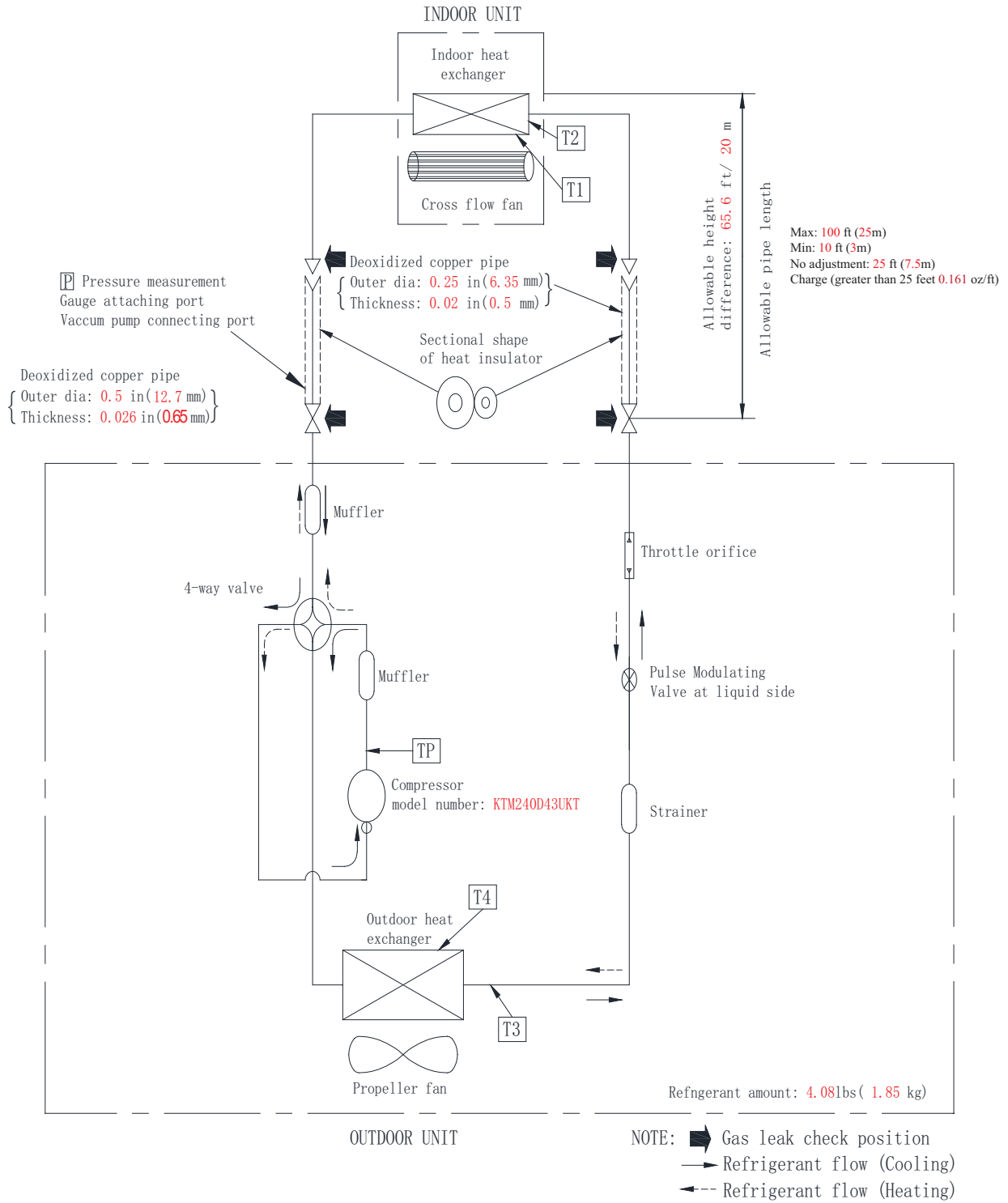

Fig. 17 — Refrigerant Cycle Diagram - Size 18K (208/230V)

REFRIGERATION CYCLE DIAGRAMS (CONT)

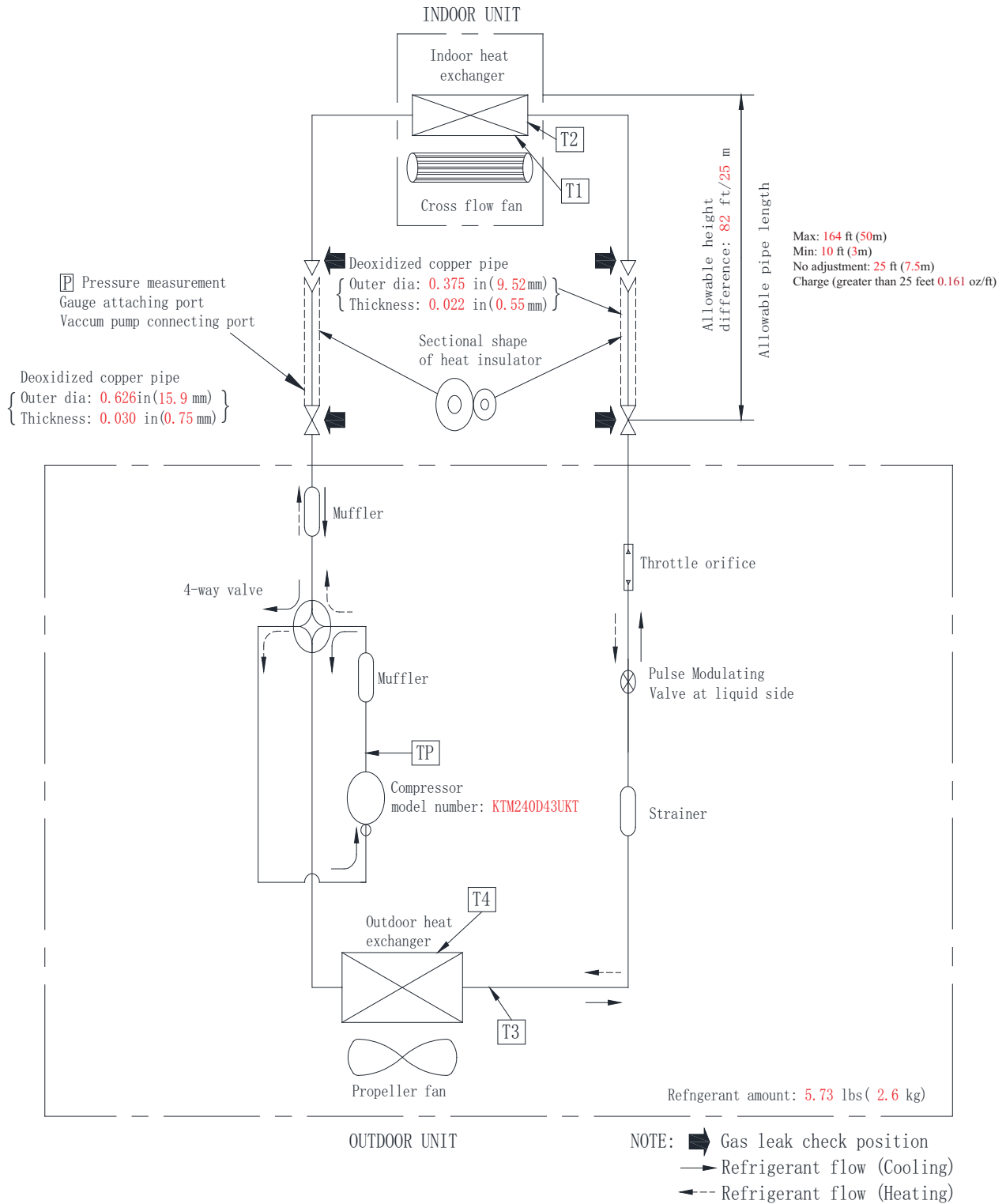

Fig. 18 — Refrigerant Cycle Diagram - Size 24K (208/230V)

REFRIGERANT LINES

General Refrigerant Line Sizing

1. The outdoor units are shipped with a full charge of R410A refrigerant. All charges, line sizing, and capacities are based on runs of 25ft. (7.6 m). For runs over 25 ft. (7.6 m), consult the long-line applications section for the proper charge adjustments.
2. The minimum refrigerant line length between the indoor and outdoor units is 10 ft. (3 m).
3. Refrigerant lines should not be buried in the ground. If it is necessary to bury the lines, not more than 36 in (914 mm) should be buried. Provide a minimum 6in (152 mm) vertical rise to the service valves to prevent refrigerant migration.
4. Both lines must be insulated. Use a minimum of 1/2in. (12.7 mm) thick insulation. Closed-cell insulation is recommended in all long-line applications.
5. Special consideration should be given to isolating interconnecting tubing from the building structure. Isolate the tubing so vibration or noise is not transmitted into the structure.

IMPORTANT: Both refrigerant lines must be insulated separately.

Table 14 displays the following maximum lengths allowed.

Table 14 — Piping and Refrigerant Information for Cooling Only and Heat Pump Systems

SYSTEM SIZE			12K	9K	12K	18K	24K
			(115 V)	(208/230 V)	(208/230 V)	(208/230 V)	(208/230 V)
Piping	Min. Piping Length	ft. (m)	10 (3)	10 (3)	10 (3)	10 (3)	10 (3)
	Standard Piping Length	ft. (m)	25 (7.5)	25 (7.5)	25 (7.5)	25 (7.5)	25 (7.5)
	Max. outdoor – indoor height difference (OU higher than IU)	ft. (m)	33 (10)	33 (10)	33 (10)	66 (20)	82 (25)
	Max. outdoor – indoor height difference (IU higher than OU)	ft. (m)	33 (10)	33 (10)	33 (10)	66 (20)	82 (25)
	Max. Piping Length with no additional refrigerant charge per System (Standard Piping length)	ft. (m)	25 (7.5)	25 (7.5)	25 (7.5)	25 (7.5)	25 (7.5)
	Total Maximum Piping Length per system	ft. (m)	82 (25)	82 (25)	82 (25)	98 (30)	164 (50)
	Additional refrigerant charge (between Standard – Max piping length)	Oz/ft (g/m)	0.161(15)	0.161(15)	0.161(15)	0.161(15)	0.322(30)
	Suction Pipe (size – connection type)	In (mm)	ø1/2" (12.7)	ø3/8" (9.52)	ø1/2" (12.7)	ø1/2" (12.7)	ø5/8" (15.9)
	Liquid Pipe (size – connection type)	In (mm)	ø1/4" (6.35)	ø1/4" (6.35)	ø1/4" (6.35)	ø1/4" (6.35)	ø3/8" (9.52)
Refrigerant	Refrigerant Type	Type	R410A	R410A	R410A	R410A	R410A
	Charge Amount	lb. (kg)	2.47(1.12)	2.6(1.18)	2.6(1.18)	4.08(1.85)	5.73(2.6)

- The charge amount listed in Table 14 is for piping runs up to 25 ft. (7.6 m).
- For piping runs greater than 25 ft. (7.6 m), add refrigerant up to the allowable length as specified in Table 15.

Long Line Applications.:

1. No change in line sizing is required.
2. Add refrigerant per Table 15.

Table 15 — Additional Charge

UNIT SIZE	TOTAL LINE LENGTH		ADDITIONAL CHARGE, OZ/FT. FT (M)				
	Min	Max	10-25 (3-8)	>25-82 (8-25)	>82-98 (25-30)	>98-164 (30-50)	>164-213 (50-65)
9	10 (3)	82 (25)	None	0.16	0.16	0.32	0.32
12		98 (30)					
18		164 (50)		0.32	0.32	0.32	
24							

SYSTEM EVACUATION AND CHARGING

⚠ CAUTION

UNIT DAMAGE HAZARD
Failure to follow this caution may result in equipment damage or improper operation.

Never use the system compressor as a vacuum pump.

Refrigerant tubes and indoor coil should be evacuated using the recommended deep vacuum method of 500 microns. Always break a vacuum with dry nitrogen.

System Vacuum and Charge

Using Vacuum Pump

1. Completely tighten all flare nuts and connect manifold gage charge hose to a charge port of the low side service valve (see Fig. 19).
2. Connect charge hose to vacuum pump.
3. Fully open the low side of manifold gage (see Fig. 20).
4. Start vacuum pump.
5. Evacuate using the triple evacuation method.
6. After evacuation is complete, fully close the low side of manifold gage and stop operation of vacuum pump.
7. The factory charge contained in the outdoor unit is good for up to 25 ft. (8 m) of line length. For refrigerant lines longer than 25 ft. (8 m), add refrigerant as specified in the Table 15.
8. Disconnect charge hose from charge connection of the low side service valve.
9. Fully open service valves B and A.
10. Securely tighten caps of service valves.

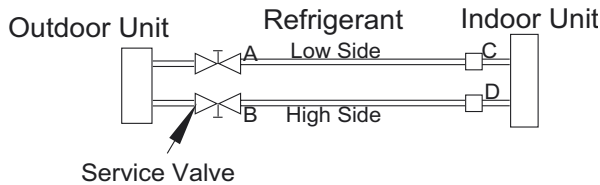

Fig. 19 —Service Valve

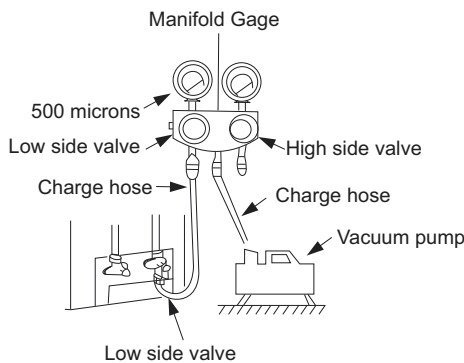

Fig. 20 —Manifold

Deep Vacuum Method

The deep vacuum method requires a vacuum pump capable of pulling a vacuum of 500 microns and a vacuum gage capable of accurately measuring this vacuum depth. The deep vacuum method is the most positive way of assuring a system is free of air and liquid water (see Fig. 21).

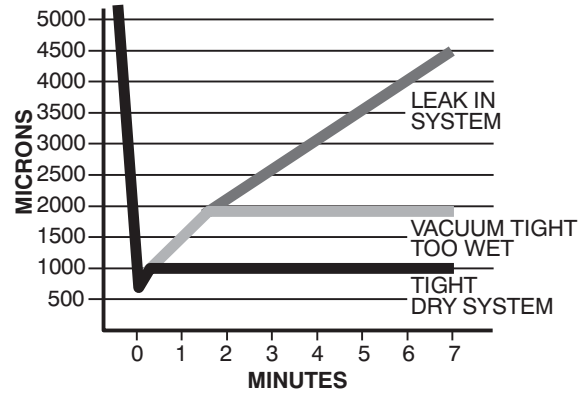

Fig. 21 —Deep Vacuum Graph

Triple Evacuation Method

The triple evacuation method should be used. Refer to Fig. 22 and proceed as follows:

1. Pump system down to 500 MICRONS of mercury and allow pump to continue operating for an additional 15 minutes.
2. Close service valves and shut off vacuum pump.
3. Connect a nitrogen cylinder and regulator to system and open until system pressure is 2 psig.
4. Close service valve and allow system to stand for 10 minutes. During this time, dry nitrogen will be able to diffuse throughout the system absorbing moisture.
5. Repeat this procedure as indicated in Fig. 22. System will then be free of any contaminants and water vapor.

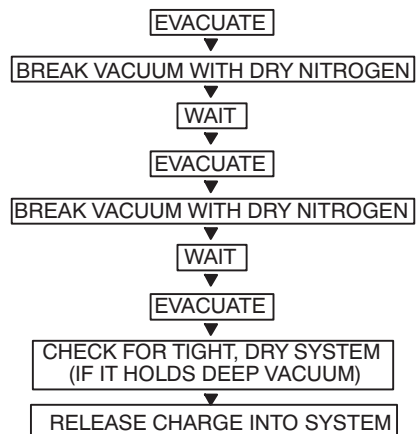

Fig. 22 —Triple Evacuation Method

Final Tubing Check

IMPORTANT: Check to be certain factory tubing on both indoor and outdoor unit has not shifted during shipment. Ensure tubes are not rubbing against each other or any sheet metal. Pay close attention to feeder tubes, making sure wire ties on feeder tubes are secure and tight.

ELECTRONIC FUNCTIONS

Abbreviation:

- T1: Indoor room temperature
- T2: Coil temperature of indoor heat exchanger middle.
- T2B: Coil temperature of indoor heat exchanger outlet.
- T3: Coil temperature of condenser
- T4: Outdoor ambient temperature
- T5: Compressor discharge temperature
- Td: Target temperature
- Ts: Set Point Temperature

Main Protection

Three minute delay for compressor restart

Less than a 1 minute delay for the initial start-up and a 3 minute delay for subsequent starts.

Compressor high temperature cutout

The unit stops working when the compressor high temperature cutout opens, and restarts after the compressor high temperature cutout closes.

Compressor discharge temperature protection

Compressor discharge temp. $T5 > 239^\circ\text{F} (115^\circ\text{C})$ for 5s, compressor stops.

Fan speed is out of control

When the indoor fan speed is too low (300RPM) or too high (1500RPM) for a certain time, the unit stops and the LED displays the failure.

Inverter module protection

The inverter module has a protection function for current, voltage and temperature. If any of these protections engage, the corresponding code displays on the indoor unit and the unit stops working.

Indoor fan delayed open function

When the unit starts up, the louver is active immediately and the indoor fan opens 10s later. If the unit is running in the HEATING mode, the indoor fan is also controlled by the anti-cold wind function.

Compressor preheating functions

Preheat parameters: When the T4 (outdoor ambient temperature) $< 37.4^\circ\text{F} (3^\circ\text{C})$, preheat function is activated.

Zero crossing detection error protection

If the AC detects the time interval is not correct for a continuous 240s, the unit stops and the LED displays the failure. The correct zero crossing signal time interval should be between 6-13ms.

Sensor protection at open circuit and breaking disconnection

If only one temperature sensor malfunctions, the air conditioner continues to work however the error code displays on the LED, in the event of any emergency use. If more than one temperature sensor malfunctions, the air conditioner stops working.

Refrigerant leakage detection

This function is only active in the COOLING mode. The function helps prevent the compressor from being damaged by a refrigerant leakage or a compressor overload.

Open condition:

When the compressor is active, the evaporator T2 coil temperature value has no or very little change.

Operation Modes and Functions

FAN Mode

1. Outdoor fan and compressor stop
2. Temperature setting function is disabled and no setting temperature appears.
3. Indoor fan can be set to high/med/low/auto
4. The louver operates same as in the COOLING mode.
5. Auto fan

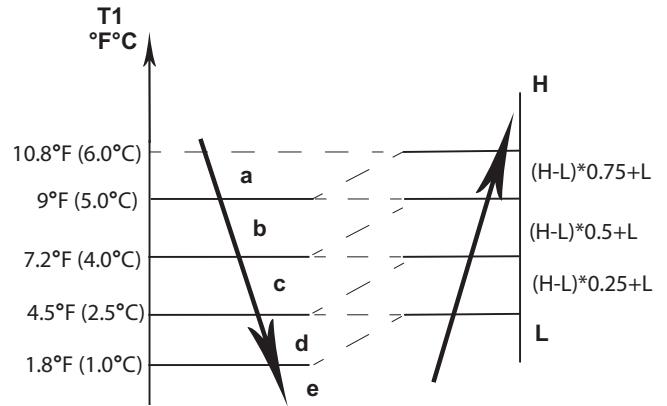

Fig. 23 —AUTO FAN Mode

COOLING Mode

Compressor Running Rules:

- When $T1 - T_s < -4^\circ\text{F} (-2^\circ\text{C})$, the compressor stops.
- When $T1 - T_s > -1^\circ\text{F} (-0.5^\circ\text{C})$, the compressor activates.
- When the AC runs in the mute mode, the compressor runs with low frequency.
- When the current is more than setting value, the current protection function activates, and the compressor stops.

Outdoor Fan Running Rules:

The outdoor unit runs at a different fan speed according to T4. For different outdoor units, the fan speeds differ.

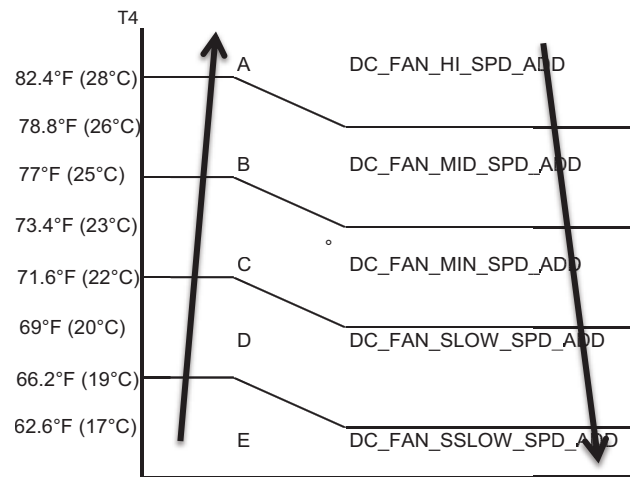

Fig. 24 —Outdoor Fan Running Rules

Indoor Fan Running Rules:

- In the **COOLING** mode, the indoor fan runs continuously and the user can select any of the following speeds: **HIGH**, **MEDIUM**, **LOW** and **AUTO**.
- When the setting temperature is reached, if the compressor stops running, the indoor fan motor runs in the minimum or setting speed (see Fig. 25).

Setting Fan Speed	T1-Td °F (°C)		Actual Fan Speed
H	8.1°F (4.5°C)	A	H + (H+=H+G)
	5.4°F (3.0°C)	B	H (=H)
	2.7°F(1.5°C)	C	H - (H- =H-G)
M	8.1°F (4.5°C)	D	M + (M+=M+Z)
	5.4°F (3.0°C)	E	M (M=M)
	2.7°F(1.5°C)	F	M - (M- =M-Z)
L	8.1°F (4.5°C)	G	L + (L+=L+D)
	5.4°F (3.0°C)	H	L (L=L)
	2.7°F(1.5°C)	I	L - (L- =L-D)

Fig. 25 —Indoor Fan Running Rules

The **AUTO** fan adheres to the following rules (see Fig. 26):

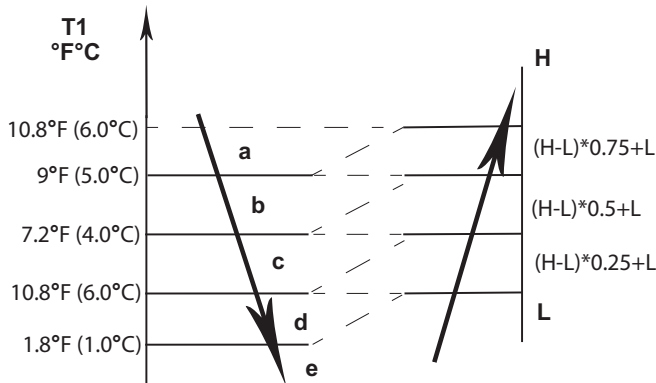

Fig. 26 —AUTO FAN Running Rules

Compressor Temperature Protection

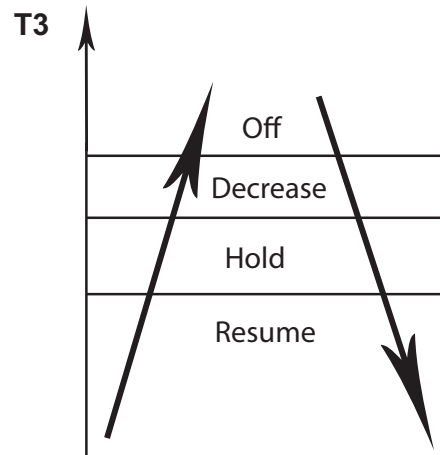

Fig. 27 —Compressor Temperature Protection

- Off:** Compressor stops
- Decrease:** Decrease the running frequency to the lower level
- Hold:** Keep the current frequency
- Resume:** No limitation for frequency

When the condenser temperature is higher than the setting value, the compressor stops.

Evaporator Temperature Protection

When the evaporator temperature is lower than the setting value the compressor stops.

HEATING Mode

Compressor Running Rules:

- When $T1-Ts > \Delta T$, the compressor stops.
- When $T1-Ts < \Delta T - 1.5$, the compressor is on. ΔT is the programmed parameter for temperature compensation.
- When the AC runs in **MUTE** mode, the compressor runs with a low frequency.
- When the current is more than the setting value, the current protection function activates and the compressor stops.

Outdoor Fan Running Rules:

The outdoor unit runs at a different fan speed according to T4. For different outdoor units, the fan speeds differ.

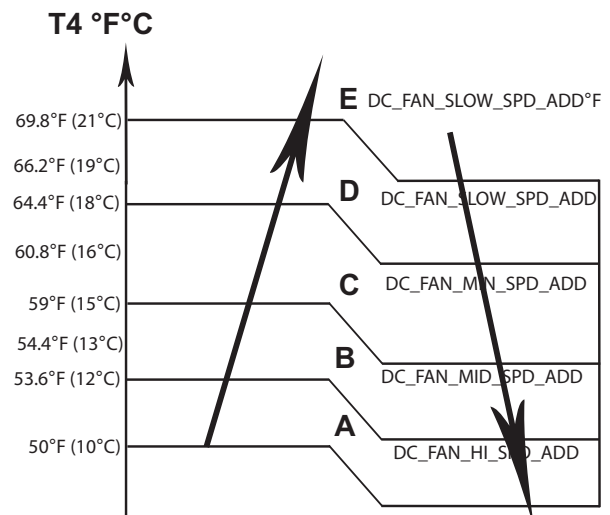

Fig. 28 —Outdoor Fan Running Rules

Indoor Fan Running Rules:

When the compressor is on, the user can set the indoor fan to either **HIGH/MED/LOW/AUTO/MUTE**. When the indoor unit coil temperature is low, the anti-cold air function starts and the indoor fan motor runs at the low speed. The speed can not be changed.

When the temperature is lower than the setting value, the indoor fan motor stops. When the indoor temperature reaches the setting temperature, the compressor stops, the indoor fan motor runs at the minimum speed or setting speed. The anti-cold air function is valid. The indoor fan is controlled as shown in Fig. 29.

Setting Fan Speed	T1-Td+34.7°F (1.5 °C)		Actual Fan Speed
H	-2.7°F(-1.5°C)		H - (H=H-G)
	-5.4°F (-3.0°C)		H (=H)
	-8.1°F(-4.5°C)		H + (H+ =H+G)
M	-2.7°F(-1.5°C)		M - (M=M-Z)
	-5.4°F (-3.0°C)		M (M=M)
	-8.1°F(-4.5°C)		M + (M+ =M+Z)
L	-2.7°F(-1.5°C)		L - (L=L-D)
	-5.4°F (-3.0°C)		L (L=L)
	-8.1°F(-4.5°C)		L + (L+ =L+D)

Fig. 29 —Indoor Fan Running Rules

Auto fan action in the **HEATING** mode.

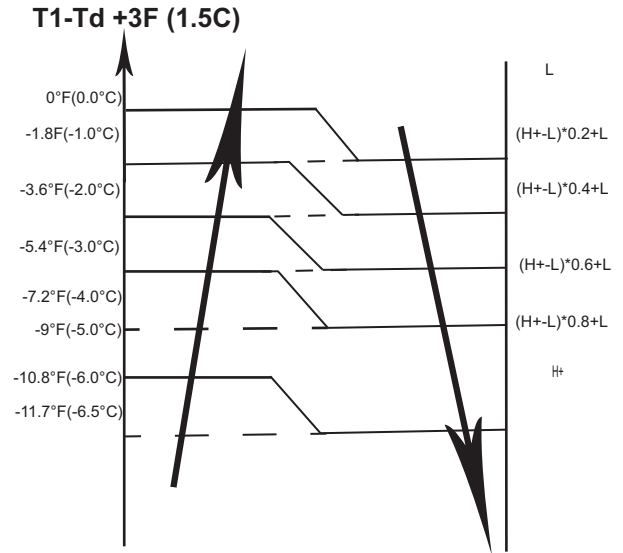

Fig. 30 —Auto Fan Action in HEATING Mode

DEFROST Mode

The air conditioning unit enters the **DEFROST** mode according to the value of temperature of T3 and the value range of temperature change of T3 plus the compressor running time (see Fig. 31).

During the **DEFROST** mode, the compressor keeps running however the indoor and outdoor motors stop.

Forced DEFROSTING Mode:

1. Press and hold **AUTO/COOL** for 5s to enter the mode. The indoor fan stops and the defrosting lamp illuminates. Use the remote

- control to exit this mode and turn off the unit to stop the normal **DEFROSTING** mode.
2. To exit the **FORCED DEFROSTING** mode, press and hold **AUTO/COOL** for 5s again.

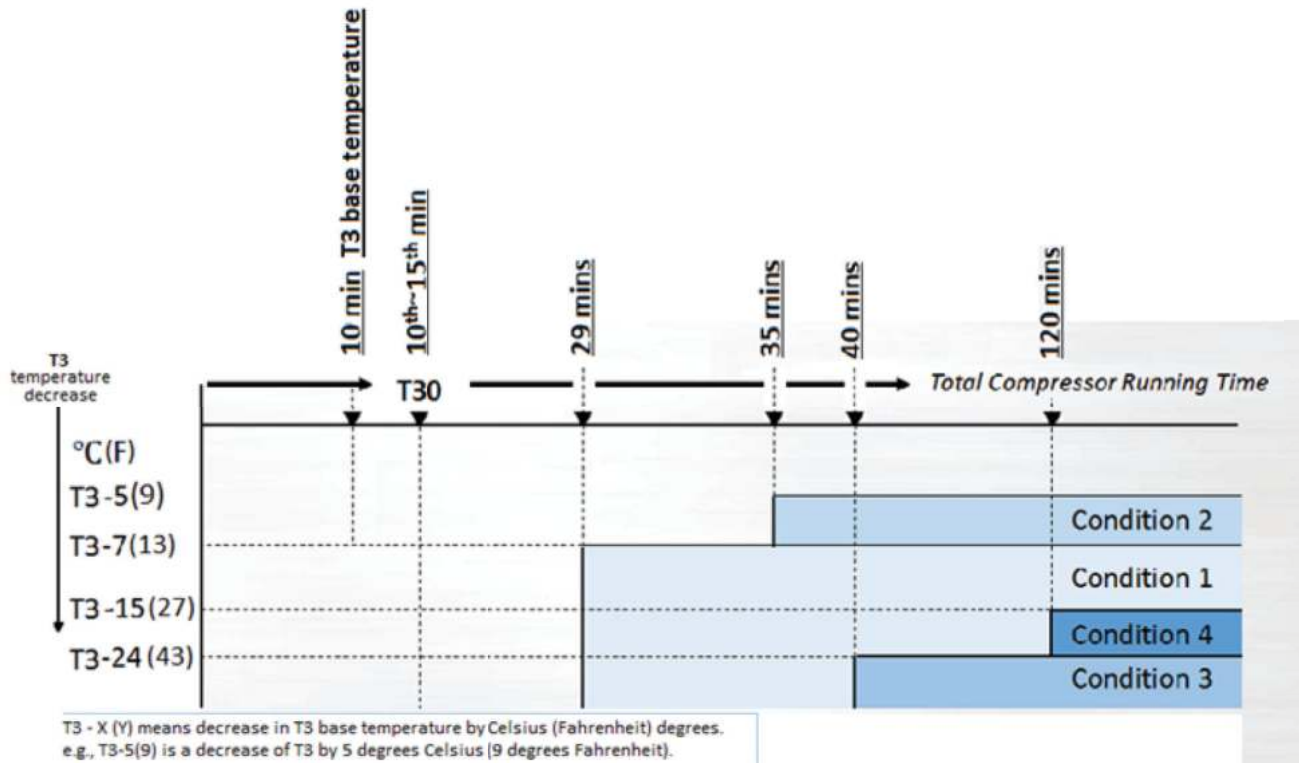

	Compressor run time	Temperature Change
Condition 1	Total compressor running time is 29 mins	T3-7°C & T30-2.5°C
Condition 2	Total compressor running time is 35 mins	T3 -5°C & T30-3°C
Condition 3	Total compressor running time is 40 mins	T3 -24°C for 3 mins
Condition 4	Total compressor running time is 120 mins	T3 -15°C
Condition 5	Total compressor running time is 120 mins	T3 or T4 ≤ -3°C

Fig. 31 — Defrost Chart

Defrost Exit Conditions: Any of the following conditions will cancel the **DEFROST** mode and change the unit to the normal **HEATING** mode:

NOTE: T3 temperature refers to the sensor reading at the time when the **DEFROST** mode begins.

- T3 temperature rises above 59°F (15°C).
- T3 temperature remains above 46°F (8°C) for more than 80 seconds.
- The unit has been in the **DEFROST** mode for 10 minutes.

The indoor unit defrost lamp illuminates and the **DF** logo appears.

Evaporator Coil Temperature Protection

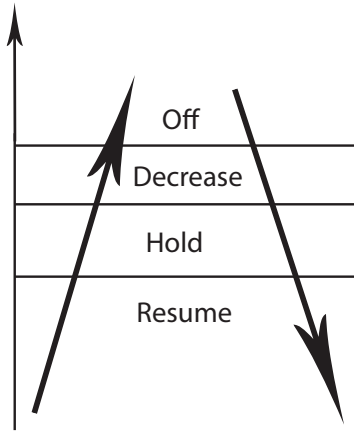

Fig. 32 —Evaporator Coil Temperature Protection

When the evaporator temperature is higher than the setting protection value, the compressor stops.

AUTO Mode

AUTO mode can be selected with the remote controller and the setting temperature can be changed between 60.0°F~86°F (16°C~30°C).

In the **AUTO** mode, the unit chooses either **COOLING**, **HEATING** or the **FAN-ONLY** mode accT2, T4 and relative humidity.

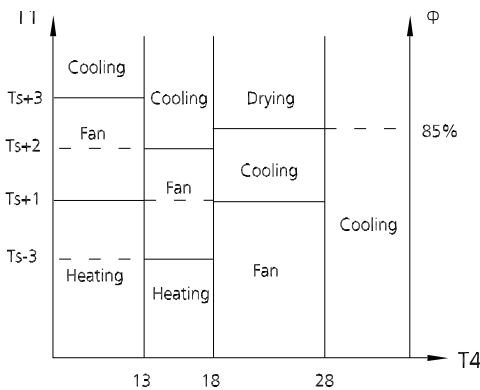

Fig. 33 —AUTO Mode

Heating*: **COOLING ONLY** models run at fan speed. The indoor fan runs in the **AUTO** fan speed for the relevant mode. The louver operates the same as in the relevant mode.

If the unit switches mode between **HEATING** and **COOLING**, the compressor repeatedly stops for a certain time and then chooses the mode according to T1-Ts. If the setting temperature is modified, the unit selects a running function again.

DRYING mode

The indoor fan speed is fixed at breeze and can not be changed. The louver angle is the same as in the **COOLING** mode.

Low Indoor Room Temperature Protection

In the **DRYING** mode, if the room temperature is lower than 50°F (10°C), the compressor stops and does not resume until the room temperature exceeds 53.6°F (12°C).

Evaporator anti-freezing protection, condenser high temperature protection and outdoor unit frequency limit are active and are the same as that in the **COOLING** mode. The outdoor fan operates the same as in **COOLING** mode.

FORCED OPERATION Function

Enter FORCED OPERATION function:

When the machine is off, press **TOUCH** to engage the **Forced Auto Mode**. Press **TOUCH** again, within 5 seconds, to engage the **FORCED COOLING** mode. In **FORCED AUTO**, **FORCED COOLING** or any other operation mode, press **TOUCH** to turn off the unit.

In the **FORCED OPERATION** mode, all general protections and the remote controller are available.

Operation Rules:

FORCED COOLING mode:

The compressor runs at the F2 frequency and the indoor fan runs as a breeze. After running for 30 minutes, the unit enters the **AUTO** mode at a 75.2°F (24°C) setting temperature.

FORCED AUTO mode:

The **FORCED AUTO** mode is the same as the normal **AUTO** mode with a 75.2°F (24°C) setting temperature.

AUTO-RESTART function

The indoor unit is equipped with an **AUTO-RESTART** function, which is carried out through an auto-restart module. In case of a sudden power failure, the module memorizes the setting conditions before the power failure. The unit resumes the previous operation setting (not including the swing function) automatically 3 minutes after the power returns.

If the memorization condition is the **FORCED COOLING** mode, the unit runs in the **COOLING** mode for 30 minutes and enters the **AUTO** mode as 75.2°F (24°C) setting temp.

If the air conditioner turns off before the unit powers off and the air conditioner is required to restart immediately, the compressor delays for 1 minute when the power is on. Under other conditions, the compressor has a 3 minute delay when it restarts.

Refrigerant Leakage Detection

With this new technology, the display area displays **EC** when the outdoor unit detects a refrigerant leak.

46°F (8°C) Heating

When the compressor is running, the indoor fan motor runs without the anti-cold air function. When the compressor is off, the indoor fan motor is off.

POINT CHECK FUNCTION

Press the remote controller **LED DISPLAY** or **LED** or **MUTE** three times, and then press **AIR DIRECTION** or **SWING** three times within ten seconds (the buzzer rings for two seconds). The air conditioner enters the information enquiry status.

The user can press **LED DISPLAY** or **AIR DIRECTION** to check the next command. When the air conditioner enters the information enquiry status, it displays the code name in 2 seconds. When the air conditioner enters the information enquiry status, it displays the code value in the next 25 seconds.

Table 16 — Enquiry Information

ENQUIRY INFORMATION	DISPLAYING CODE	MEANING
T1	T1	T1 temp.
T2	T2	T2 temp.
T3	T3	T3 temp.
T4	T4	T4 temp.
T2B	Tb	T2B temp.
TP	TP	TP (T5) temp.
TH	TH	TH temp.
Targeted Frequency	FT	Targeted Frequency
Actual Frequency	Fr	Actual Frequency
Indoor Fan Speed	IF	Indoor Fan Speed
Outdoor Fan Speed	OF	Outdoor Fan Speed
EXV Opening Angle	LA	EXV Opening Angle
Compressor Continuous Running Time	CT	Compressor Continuous Running Time
Compressor Stop Issues	ST	Compressor Stop Issues

When the air conditioner enters the information enquiry status, the **LED** displays the code value within 25 seconds (see Table 17).

Table 17 — Enquiry Information

ENQUIRY INFORMATION	DISPLAY VALUE	MEANING	REMARK
T1, T2, T3, T4, T2B, TP, TH, Targeted Frequency, Actual Frequency	- 1F,- 1E,- 1d,- 1c,- 1b,- 1A	- 25,- 24,- 23,- 22,- 21,- 20	1. All the displaying temperature is actual value. 2. Temperature is °C, no matter the remote. 3. T1, T2, T3, T4, T2B display range:- 25~ 70, 4. TP display range:- 20~ 130. 5. Frequency display range: 0~159HZ. 6. If the range, it displays the maximum value or minimum value.
	- 19—99	- 19—99	
	A0,A1,●●●A9	100,101,●●●109	
	b0,b1,●●●b9	110,111,●●●119	
	c0,c1,●●●c9	120,121,●●●129	
	d0,d1,●●●d9	130,131,●●●139	
	E0,E1,●●●E9	140,141,●●●149	
	F0,F1,●●●F9	150,151,●●●159	
Indoor fan speed/ Outdoor fan speed	0	OFF	
	1,2,3,4	Low speed, Medium speed, High speed, Turbo	For some big capacity motors
	14- FF	Actual fan speed = Display value turns to decimal value and then multiply 10. The unit is RPM.	For some small capacity motors the display value is 14-FF (hexadecimal), the corresponding fan speed range is from 200-2550 RPM.
EXV opening angle	0- FF	Actual EXV opening value = Display value turns to decimal value and then multiply by 2.	
Compressor continuous running time	0- FF	0- 255 minutes	If the actual value exceeds the range, it displays the maximum value or minimum value.
Compressor stop causes	0- 99	For a detailed meaning, please consult with an engineer	Decimal display
Reserve	0- FF		

TROUBLESHOOTING

Safety

Electricity power is kept in capacitors even if the power supply is shut off.

NOTE: Remember to discharge the electricity power in capacitor.

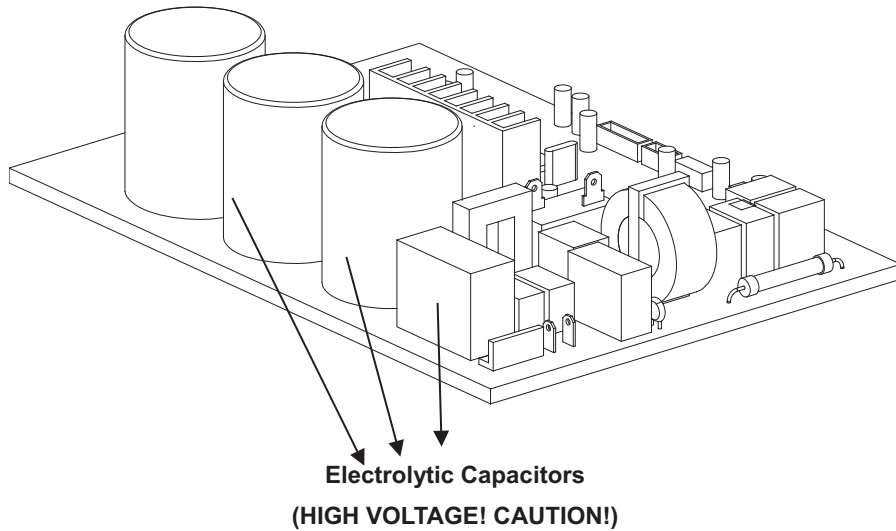

Fig. 34 —Electrolytic Capacitors

For other models, connect discharge resistance (approximately 100Ω 40W) or a soldering iron (plug) between the +, - terminals of the electrolytic capacitor on the contrary side of the outdoor PCB.

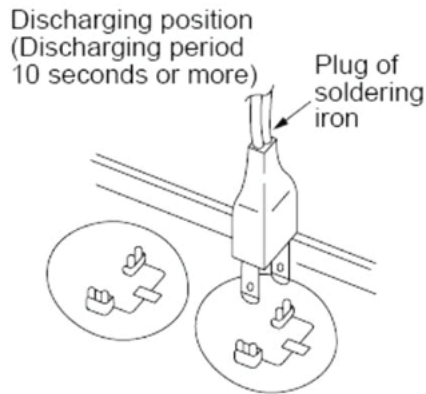

Fig. 35 —Discharge Position

NOTE: Fig. 35 is for reference only. The plug on your unit may differ.

INDOOR UNIT DIAGNOSTIC GUIDES

Table 18 — Indoor Unit Diagnostic Guide

OPERATION LAMP	TIMER LAMP	DISPLAY	LED STATUS	SOLUTION
★ 1 time	X	EH 00/ EH 0A	Indoor unit EEPROM parameter error	--
★ 2 times	X	EL 01	Indoor / outdoor units communication error	Page 32
★ 3 times	X	EH 02	Zero-crossing signal detection error	Page 34
★ 4 times	X	EH 03	The indoor fan speed is operating outside of the normal control	Page 35
★ 5 times	X	EC 51	Outdoor unit EEPROM parameter error	Page 31
★ 5 times	X	EC 52	Condenser coil temperature sensor T3 is an open circuit or has short circuited	--
★ 5 times	X	EC 53	Outdoor room temperature sensor T4 is an open circuit or has short circuited	Page 40
★ 5 times	X	EC 54	Compressor discharge temperature sensor TP is an open circuit or has short circuited	--
★ 5 times	X	EC 5b	Evaporator coil outlet temperature sensor T2B is an open circuit or has short circuited (for free-match indoor units)	--
★ 6 times	X	EH 60	Indoor room temperature sensor T1 is an open circuit or has short circuited	Page 39
★ 6 times	X	EH 61	Evaporator coil middle temperature sensor T2 is an open circuit or has short circuited	--
★ 12 times	X	EC 07	The outdoor fan speed is operating outside of the normal range	Page 37
★ 9 times	X	EH 06	Indoor PCB/Display board communication error	Page 42
★ 8 times	X	EL 0C	Refrigerant leakage detection	Page 41
★ 7 times	★	PC 00	IPM malfunction or IGBT over-strong current protection	Page 44
★ 2 times	★	PC 01	Over voltage or over low voltage protection	Page 47
★ 3 times	★	PC 02	Top temperature protection of the compressor or high temperature protection of the IPM module or high pressure protection	Page 48
★ 5 times	★	PC 04	Inverter compressor drive error	Page 50
★ 1 time	★	PC 08	Current overload protection	Page 43
★ 6 times	★	PC 40	Communication error between the outdoor main chip and the compressor driven chip	Page 53
★ 7 times	★	PC 03	Low pressure protection	Page 51
★ 1 time	O	--	Indoor units mode conflict (match with multi outdoor unit)	--

O(light) X(off) ★(flash)

NOTES:

P3

1. In the **HEATING** mode, when the outdoor temperature is lower than -25 °C for one hour, the indoor unit displays the error code **P3**. If the outdoor temperature is higher than -22°C for 10 minutes and the compressor stops for 1 hour or the outdoor temperature is higher than -5°C for 10 minutes, the unit will start.

P6

2. Low pressure protection switch is open. Check the switch and repair or leak check the unit and recharge.

Troubleshooting

Use the remote controller. If the unit does not respond to the remote, the indoor PCB needs to be replaced; if the unit does respond, then the display board needs to be replaced.

DIAGNOSIS AND SOLUTION

Outdoor Unit Error Display

Sizes 12 (115V)

After the power is on, LED1 (blue color) flashes slowly (once per second) when the unit is in standby. The LED flashes quickly (twice per second) if the unit has an issue.

Table 19 — Diagnostic Table Sizes 9K-18K

NO.	PROBLEMS	LED3 (GREEN)	LED2 (RED)	IU DISPLAY	SOLUTION
1	IPM malfunction or IGBT over - strong current protection	★	X	P0	Page 44
2	Over voltage or too low voltage protection	O	O	P1	Page 47
3	EEPROM parameter error	O	★	E5	Page 31
4	Inverter compressor drive error	X	★	P4	Page 50
5	Inverter compressor drive error	★	O	P4	Page 50
6	Inverter compressor drive error	★	★	P4	Page 50

O (light) X (off) ★ (2.5 Hz flash)

Table 20 — Diagnostic Table Size 24K

NO.	PROBLEMS	LED2 (GREEN)	LED3 (RED)	IU DISPLAY	SOLUTION
1	IPM malfunction or IGBT over - strong current protection	★	X	P0	Page 44
2	Over voltage or too low voltage protection	O	O	P1	Page 47
3	EEPROM parameter error	O	★	E5	Page 31
4	Inverter compressor drive error	X	★	P4	Page 50
5	Inverter compressor drive error	★	O	P4	Page 50
6	Inverter compressor drive error	★	★	P4	Page 50

DIAGNOSIS AND SOLUTION (CONT)

Outdoor EEPROM Parameter Error or Compressor Driven Chip EEPROM Parameter Error (EC51)

Description: Outdoor PCB main chip does not receive feedback from the EEPROM chip or the compressor driven chip.

Recommended parts to repair:

- Outdoor PCB

Troubleshooting

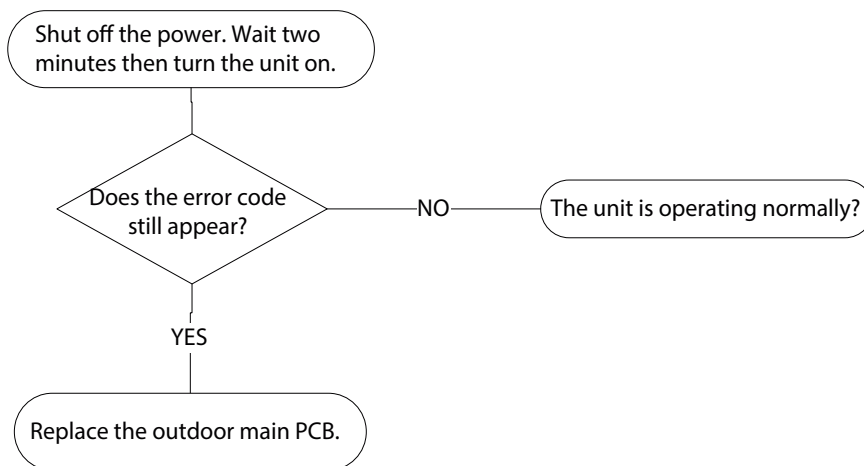

Remarks:

EEPROM: A read-only memory, with contents that can be erased and reprogrammed using a pulsed voltage.

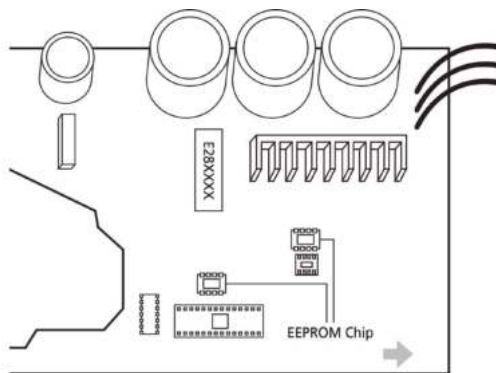

Fig. 36 — EEPROM

NOTE: For certain models, the outdoor PCB could not be removed separately. In this case, the outdoor electric control box should be replaced as a whole. This pictures are only for reference and the actual appearance may vary.

DIAGNOSIS AND SOLUTION (CONT)

Indoor and Outdoor Unit Communication Error (EL01)

Description: The indoor unit cannot communicate with the outdoor unit

Recommended parts to repair:

- Indoor PCB
- Outdoor PCB
- Short-circuited component

Troubleshooting:

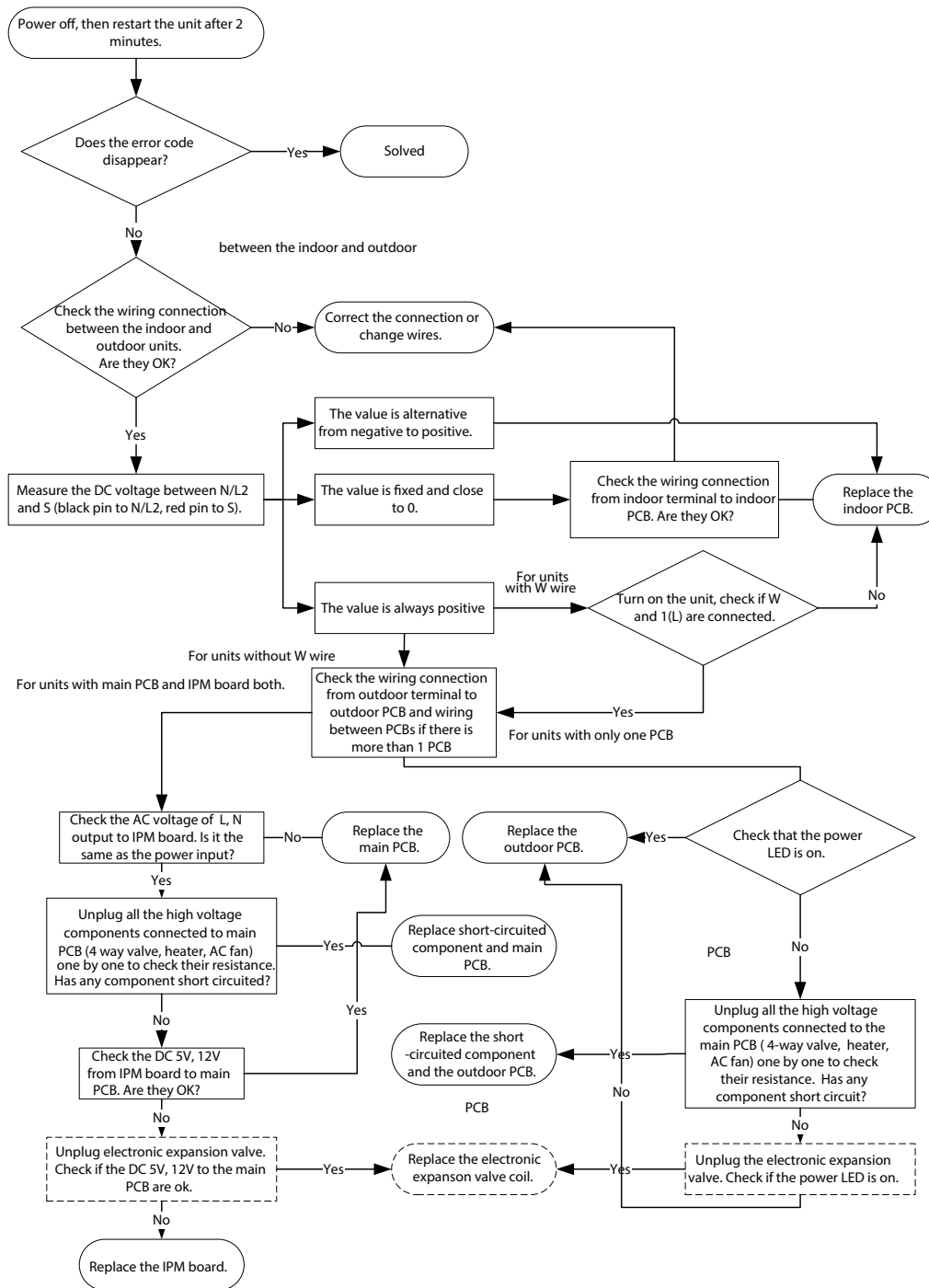

For certain models, outdoor PCB could not be removed separately. In this case, the outdoor electric control box should be replaced as a whole.

DIAGNOSIS AND SOLUTION (CONT)

Remarks:

- Use a multimeter to test the DC voltage between the 2 port (or S or L2 port) and 3 port (or N or S port) of outdoor unit.
- The red pin of multimeter connects with 2 port (or S or L2 port) while the black pin is for 3 port (or N or S port) the unit is normal running, the voltage is moving alternately as positive values and negative values
- If the outdoor unit has malfunction, the voltage has always been the positive value.
- While if the indoor unit has malfunction, the voltage has always been a certain value.

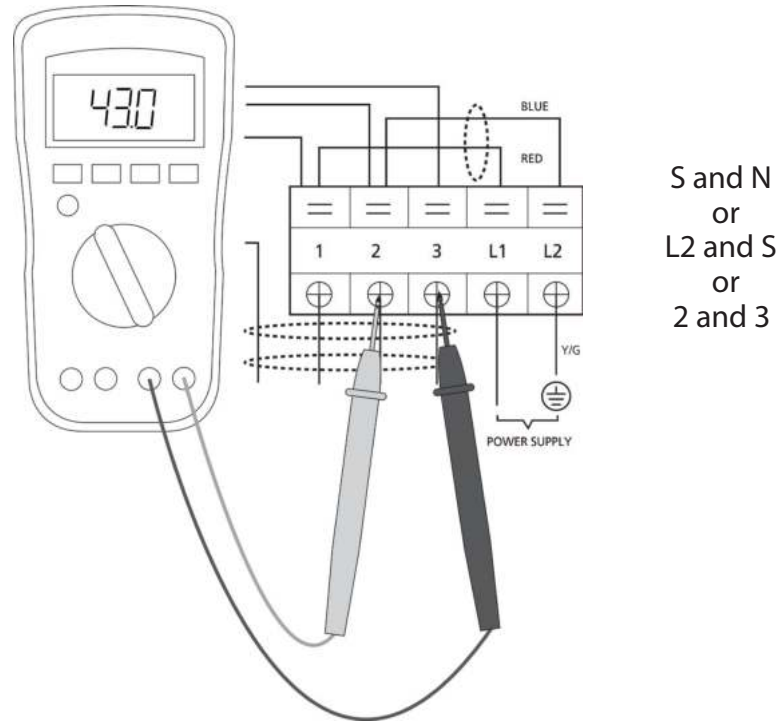

- Use a multimeter to test the reactor's resistance which does not connect with capacitor.
- The normal value should be around zero ohm. Otherwise, the reactor must have malfunction.

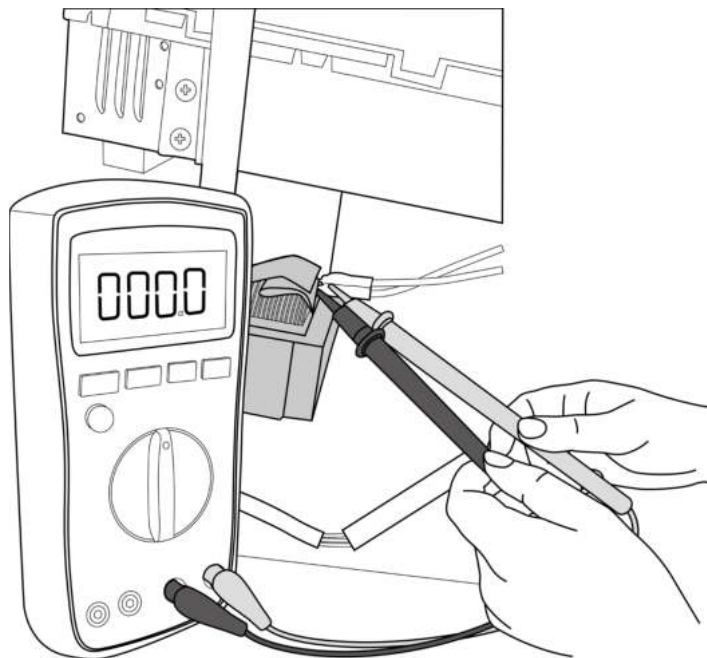

DIAGNOSIS AND SOLUTION (CONT)

Zero Crossing Detection Error Diagnosis and Solution (EH02)

Description: When the PCB does not receive a zero crossing signal feedback for 4 minutes or the zero crossing signal time interval is abnormal.

Recommended parts to repair:

- Connection wires
- Indoor main PCB

Troubleshooting and Repair:

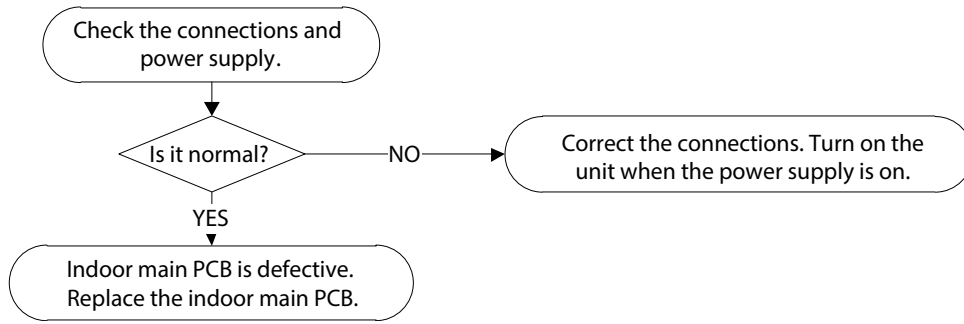

Note: Zero crossing detection error is only valid for the unit with AC fan motor. For other models, this error is invalid.

DIAGNOSIS AND SOLUTION (CONT)

The indoor fan speed is operating outside of the normal range (EH03)

Description: When the indoor fan speed remains too slow or too fast for an extended period of time, the LED displays a failure code and the unit turns off.

Recommended parts to repair:

- Connection wires
- Indoor main PCB
- Fan assembly
- Indoor main PCB

Troubleshooting

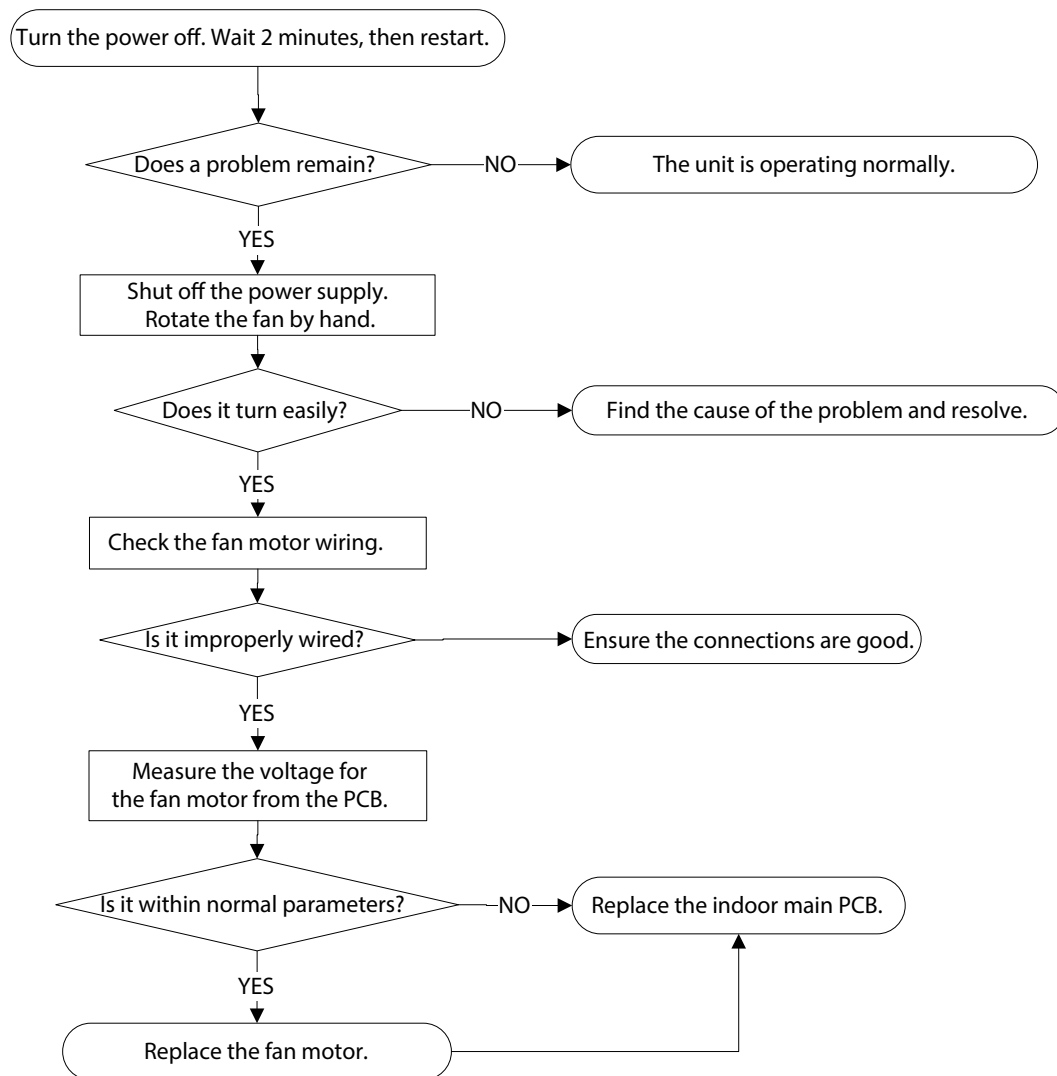

DIAGNOSIS AND SOLUTION (CONT)

Index

DC Fan Motor (Control chip is in the fan motor)

Power on and when the unit is in standby mode, measure the pin1-pin3 and pin4-pin3 voltage in the fan motor connector. If the voltage value is not in the range shown in the following table, the PCB is faulty and must be replaced.

- DC motor voltage input and output (voltage:220-240V~):

No.	Color	Signal	Voltage
1	Red	Vs/Vm	192V~380V
2	---	---	---
3	Black	GND	0V
4	White	Vcc	13.5~16.5V
5	Yellow	Vsp	0~6.5V
6	Blue	FG	13.5~16.5V

- DC motor voltage input and output (voltage: 115V~):

No.	Color	Signal	Voltage
1	Red	Vs/Vm	140V~190V
2	---	---	---
3	Black	GND	0V
4	White	Vcc	13.5~16.5V
5	Yellow	Vsp	0~6.5V
6	Blue	FG	13.5~16.5V

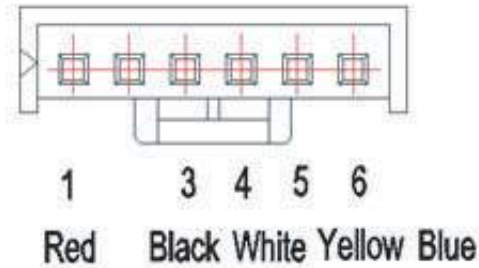

DIAGNOSIS AND SOLUTION (CONT)

The Outdoor Fan Speed is Operating Outside of Normal Range (EC07)

Description: When the outdoor fan speed remains too low or too high for a certain time, the LED displays the failure code and the AC turns off.

Recommended parts to repair:

- Connection wires
- Fan assembly
- Fan motor
- Outdoor main PCB

Troubleshooting

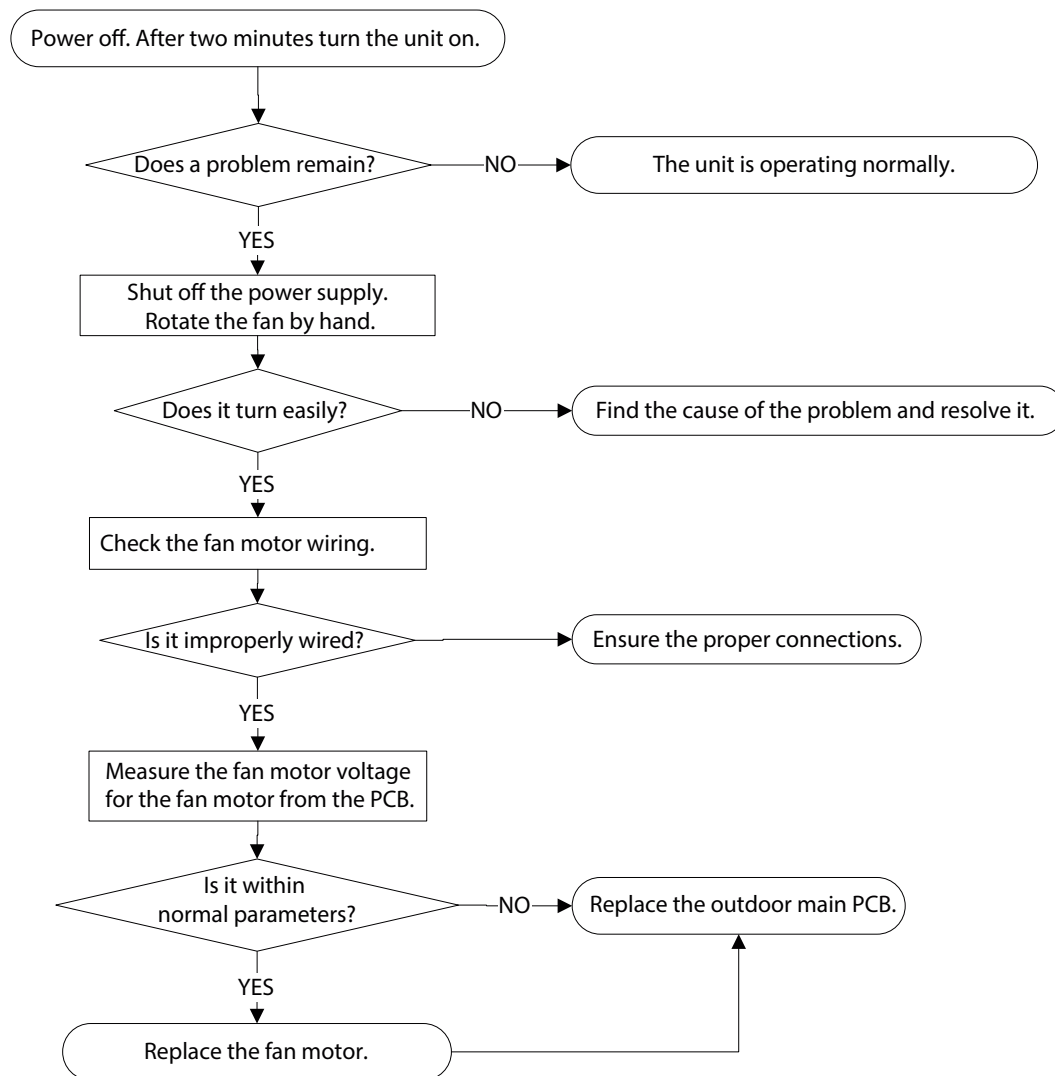

NOTE: For certain models, outdoor PCB could not be removed separately. In this case, the outdoor electric control box should be replaced as a whole.

DIAGNOSIS AND SOLUTION (CONT)

Outdoor DC Fan Motor (DC motor that controls the chip on the PCB)

1. Release the UVW connector. Measure the resistance of U-V, U-W, V-W. If the resistance is not equal to each other, the fan motor is faulty and must be replaced. Otherwise, proceed to step 2.
2. Power on the unit and when the unit is in standby, measure the pin4-5 voltage in the feedback signal connector. If the value is not 5V, change the PCB. Otherwise, proceed to step 3.
3. Rotate the fan by hand, measure the pin1-5, pin 2-5 and pin 3-5 voltage levels in the feedback signal connector. If any voltage is not in the positive voltage fluctuation, the fan motor is faulty and must be replaced.

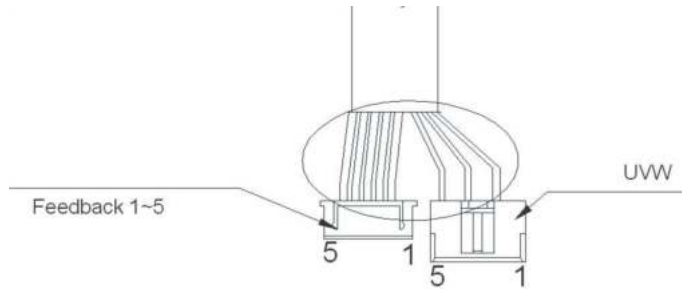

Fig. 37 — Outdoor DC Fan Motor (DC motor that controls the chip on the PCB)

NO.	1	2	3	4	5
Color	Orange	Grey	White	Pink	Black
Signal	Hu	Hv	Hw	Vcc	GND

Color	Red	Blue	Yellow
Signal	W	V	U

DIAGNOSIS AND SOLUTION (CONT)

Indoor Temperature Sensor Is an Open Circuit or a Short Circuit (T1, T2) (EH60)

Description: If the sampling voltage is lower than 0.06V or higher than 4.94V, the LED displays the failure code.

Recommended parts to repair:

- Connection wires
- Sensors
- Indoor main PCB

Troubleshooting

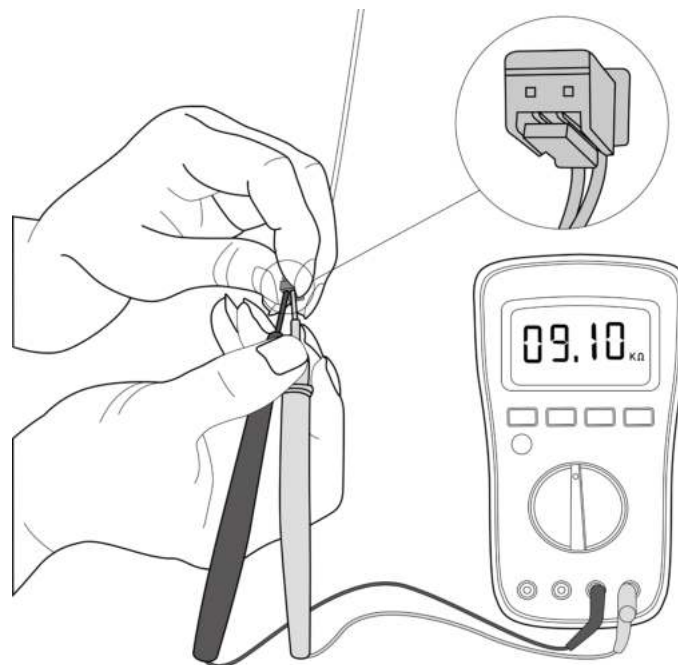
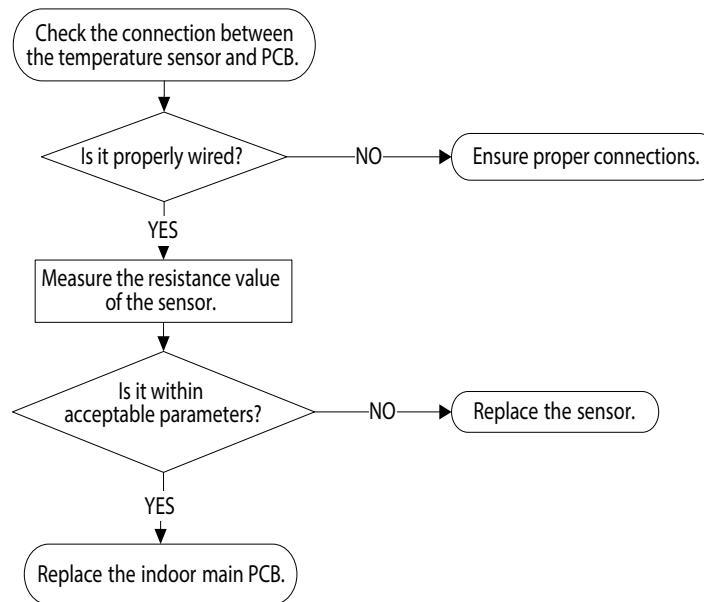

Fig. 38 — Test

NOTE: Figure 38 and the value shown within are for reference only.

DIAGNOSIS AND SOLUTION (CONT)

Outdoor Temperature Sensor Is an Open Circuit or Short Circuited (T3, T4, TP, T2B, TH) (EC53)

Description: If the sampling voltage is lower than 0.06V or higher than 4.94V, the LED displays the failure code.

Recommended parts to repair:

- Connection wires
- Sensors
- outdoor main PCB

Troubleshooting:

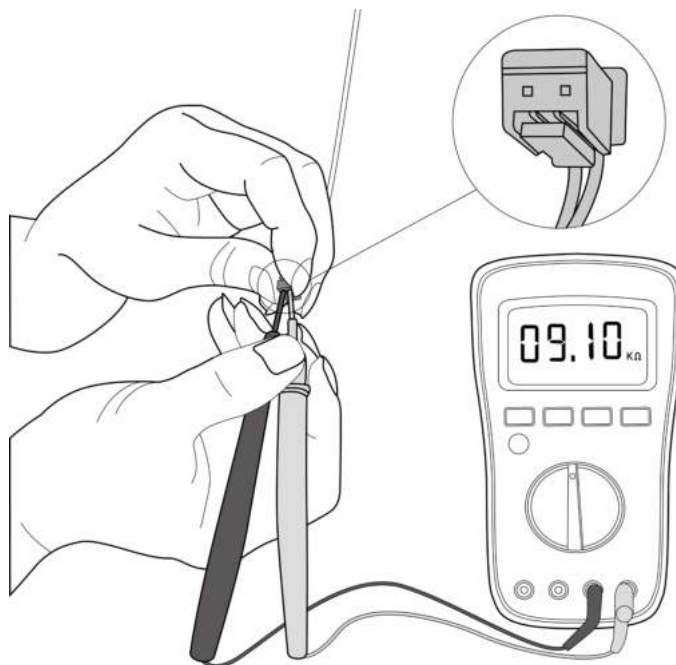
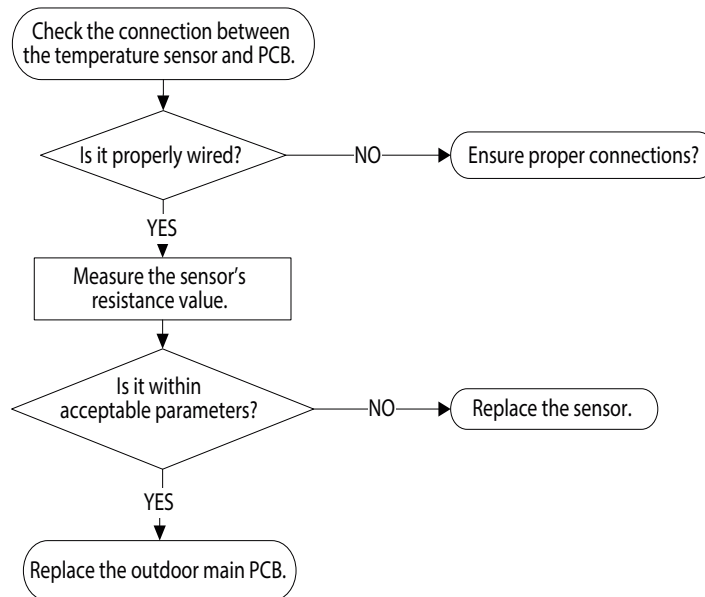

Fig. 39 —Test

NOTE: For certain model, the outdoor PCB could not be removed separately. In this case, the outdoor electric control box should be replaced as a whole. For certain models, the outdoor unit uses a combination sensor, T3,T4 and TP are the same sensor. Figure 39 and the value are for reference only.

DIAGNOSIS AND SOLUTION (CONT)

Refrigerant Leakage Detection (EL0C)

Description: Define the compressor's evaporator coil temperature (T2) starts running as Tcool.

In the initial 5 minutes after the compressor starts, if $T2 < T_{cool} - 1.8^{\circ}\text{F}$ (1°C) is not maintained for 4 seconds and the compressor runs at a frequency is higher than 50Hz however it does not maintain for a minimum of three minutes and this issue occurs 3 times, the LED displays the failure code and the unit turns off.

Recommended parts to repair:

- T2 Sensor
- Indoor PCB
- Additional refrigerant

Troubleshooting

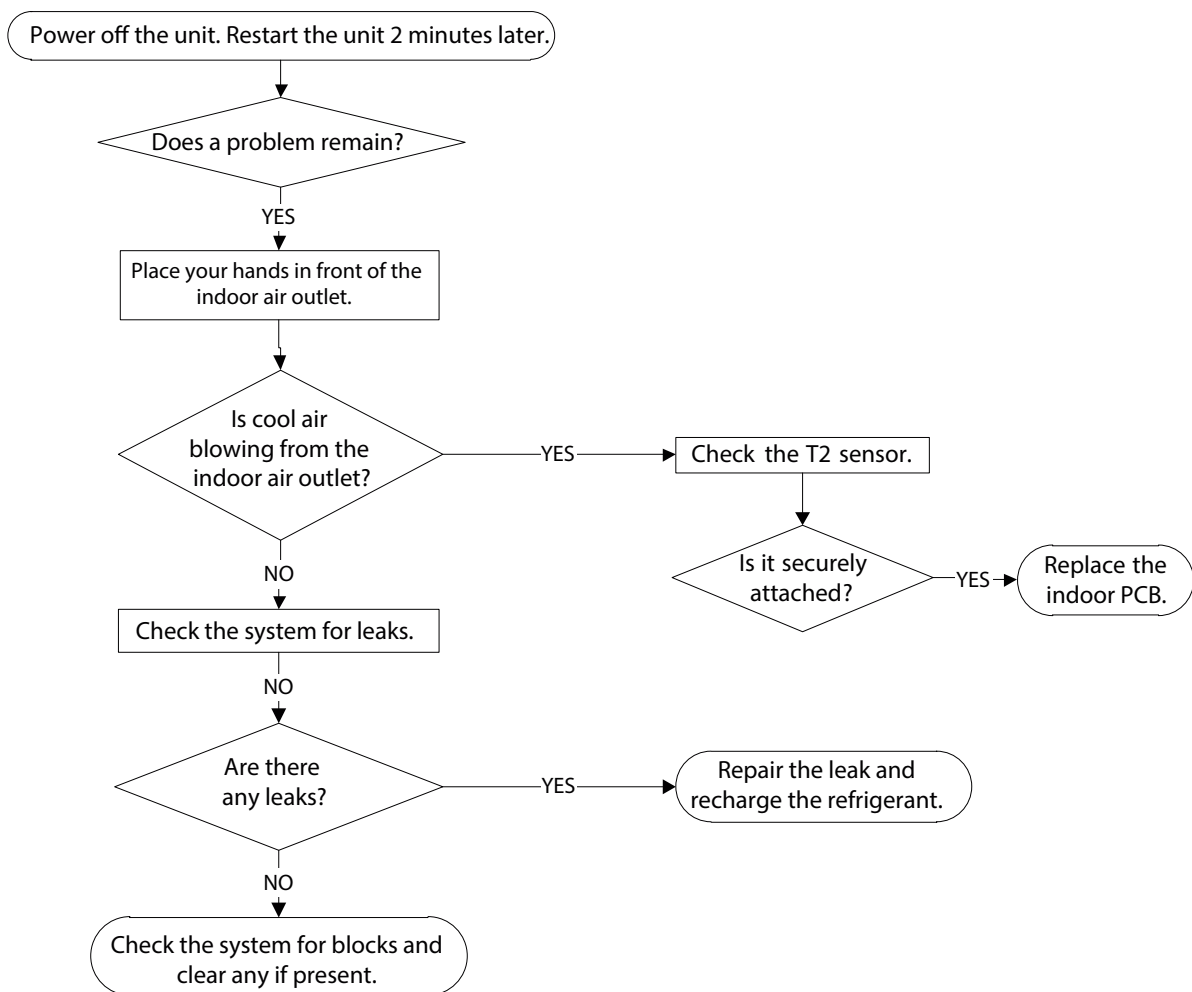

DIAGNOSIS AND SOLUTION (CONT)

Indoor PCB/Display Board Communication Error (EH06)

Description: The indoor PCB does not receive feedback from the display board.

Recommended parts to repair:

- Communication wire
- Indoor PCB
- Display board

Troubleshooting

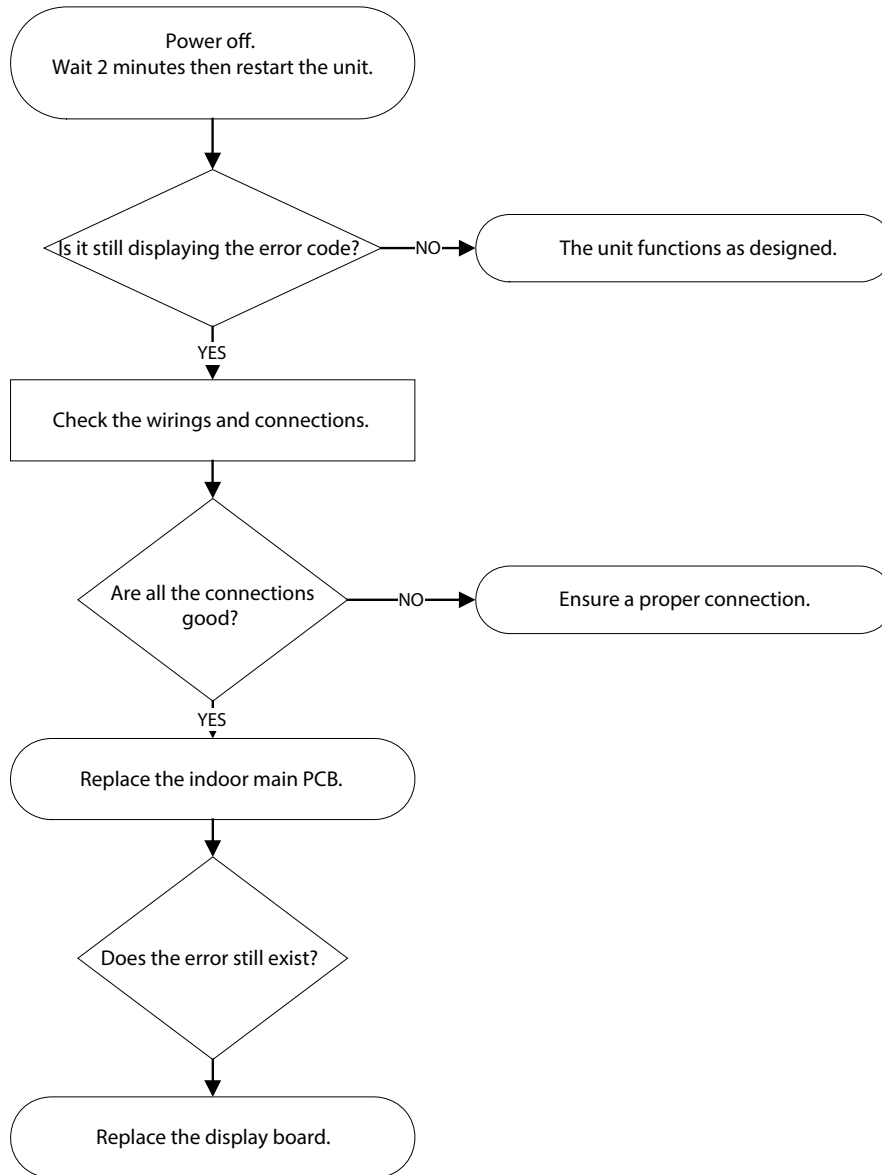

DIAGNOSIS AND SOLUTION (CONT)

Current Overload Protection (PC08)

Description: An abnormal current rise is detected by checking the specified detection circuit.

Recommended parts to repair:

- Communication wires
- Reactor
- Outdoor fan
- Outdoor PCB

Troubleshooting:

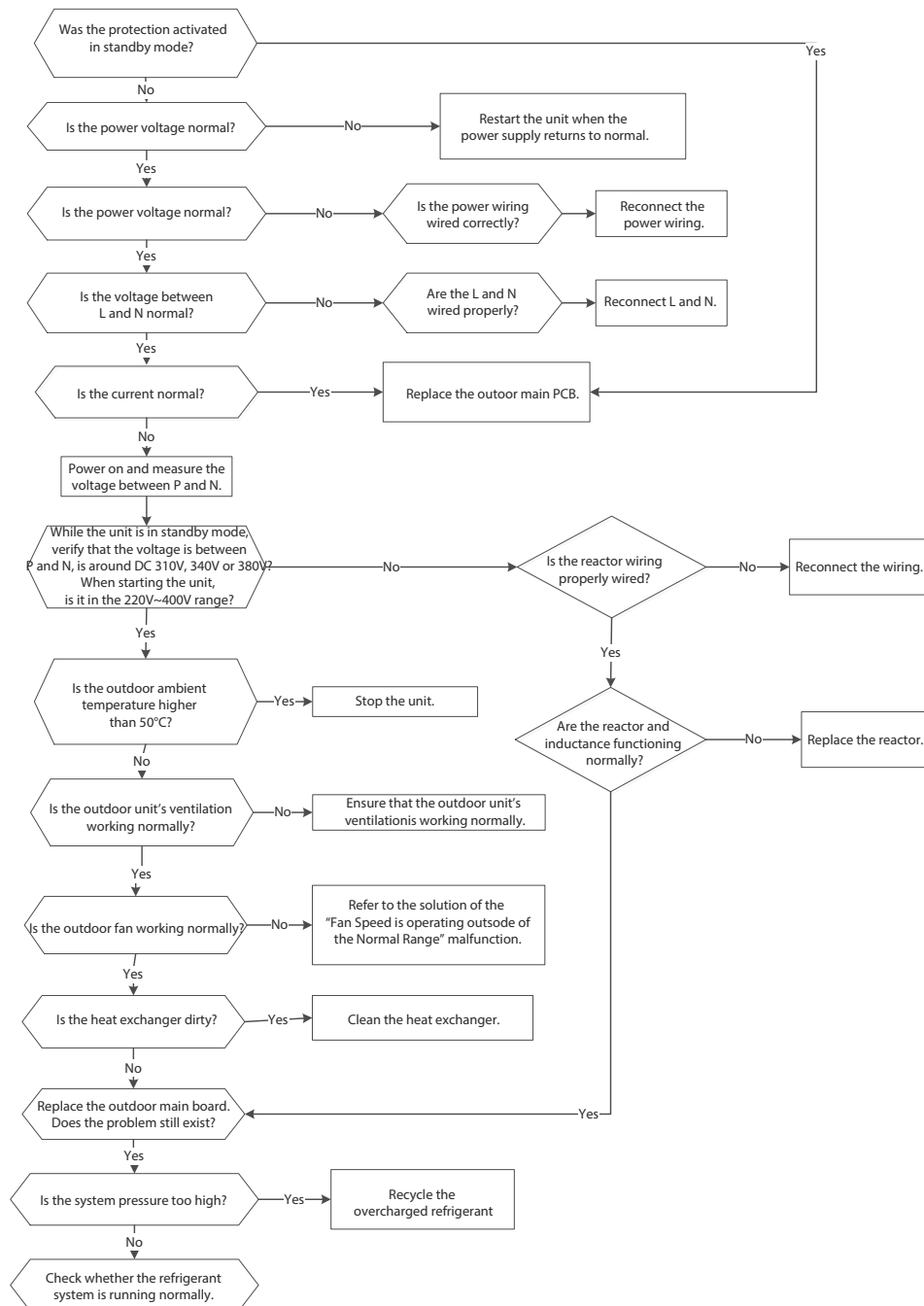

NOTE: For certain models, the outdoor PCB can not be removed separately. In the case, the outdoor electric control box should be replaced as a whole.

DIAGNOSIS AND SOLUTION (CONT)

IPM Malfunction or IGBT over-strong current protection (PC00)

Description: If the IPM sends an abnormal voltage signal to the compressor drive chip, the LED displays the failure code and the unit turns off.

Recommended parts to repair:

- Communication wires
- IPM module board
- Outdoor fan assembly
- Compressor
- Outdoor PCB

Troubleshooting

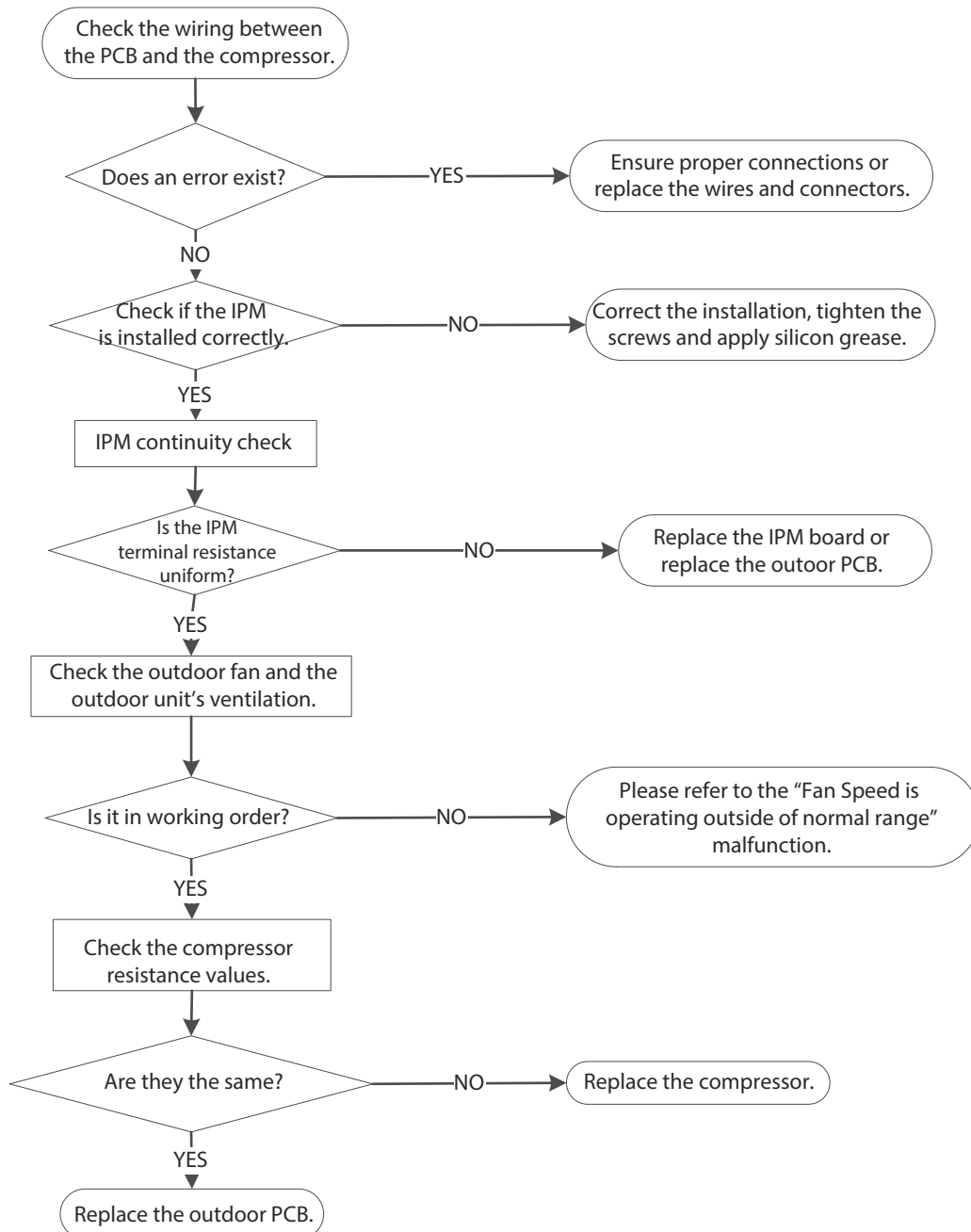

DIAGNOSIS AND SOLUTION (CONT)

Index

IPM Continuity Check



WARNING

Electricity remains in the capacitors even when the power supply is off.

Ensure the capacitors are fully discharged before troubleshooting.

1. Turn off the outdoor unit and disconnect the power supply.
2. Discharge the electrolytic capacitors and ensure all the energy storage has been discharge.
3. Disassemble the outdoor PCB or disassemble the IPM board.
4. Measure the resistance value between P and U(V,W,N), U (V,W) and N.

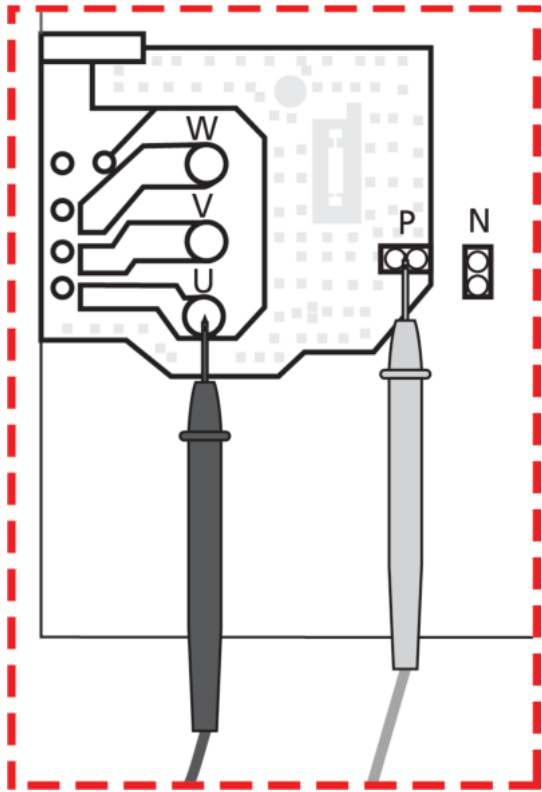
DIGITAL TESTER		RESISTANCE VALUE	DIGITAL TESTER		RESISTANCE VALUE
(+) Red	(-) Black		(+) Red	(-) Black	
P	N	∞ (Several M Ω)	U	N	∞ (Several M Ω)
	U		V		
	V		W		
	W		-		



DIAGNOSIS AND SOLUTION (CONT)

Compressor Check

Disconnect the compressor and check the resistance between U-V, V-W and U-W, and all 3 values should be equal. If not, the compressor is faulty and needs to be replaced.

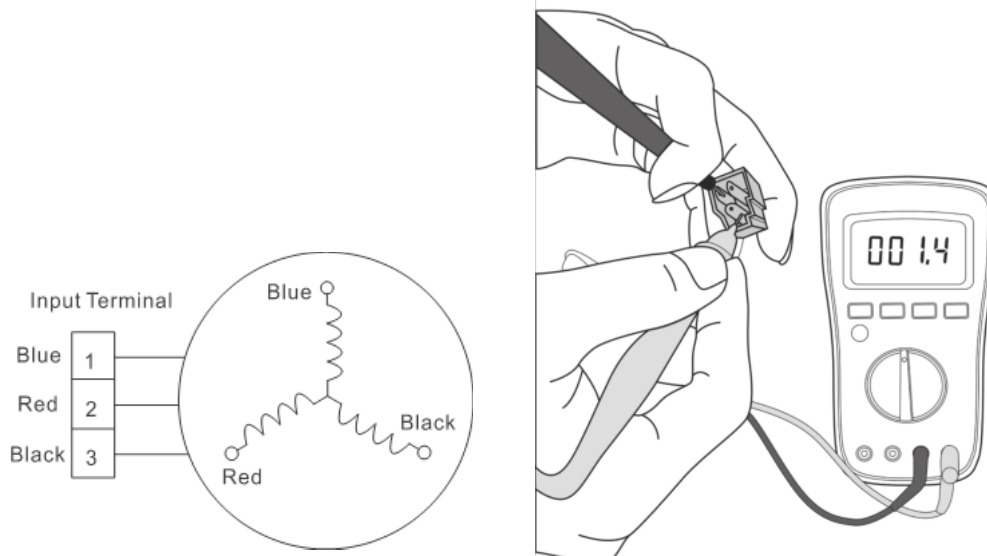

Fig. 40 — Compressor Checks

NOTE: Figure 40 is for reference only.

DIAGNOSIS AND SOLUTION (CONT)

Over voltage or low voltage protection (PC01)

Description: Abnormal increases or decreases in voltage are detected by checking the specified voltage detection circuit.

Recommended parts to repair:

- Power supply wires
- IPM module board
- PCB
- Reactor

Troubleshooting

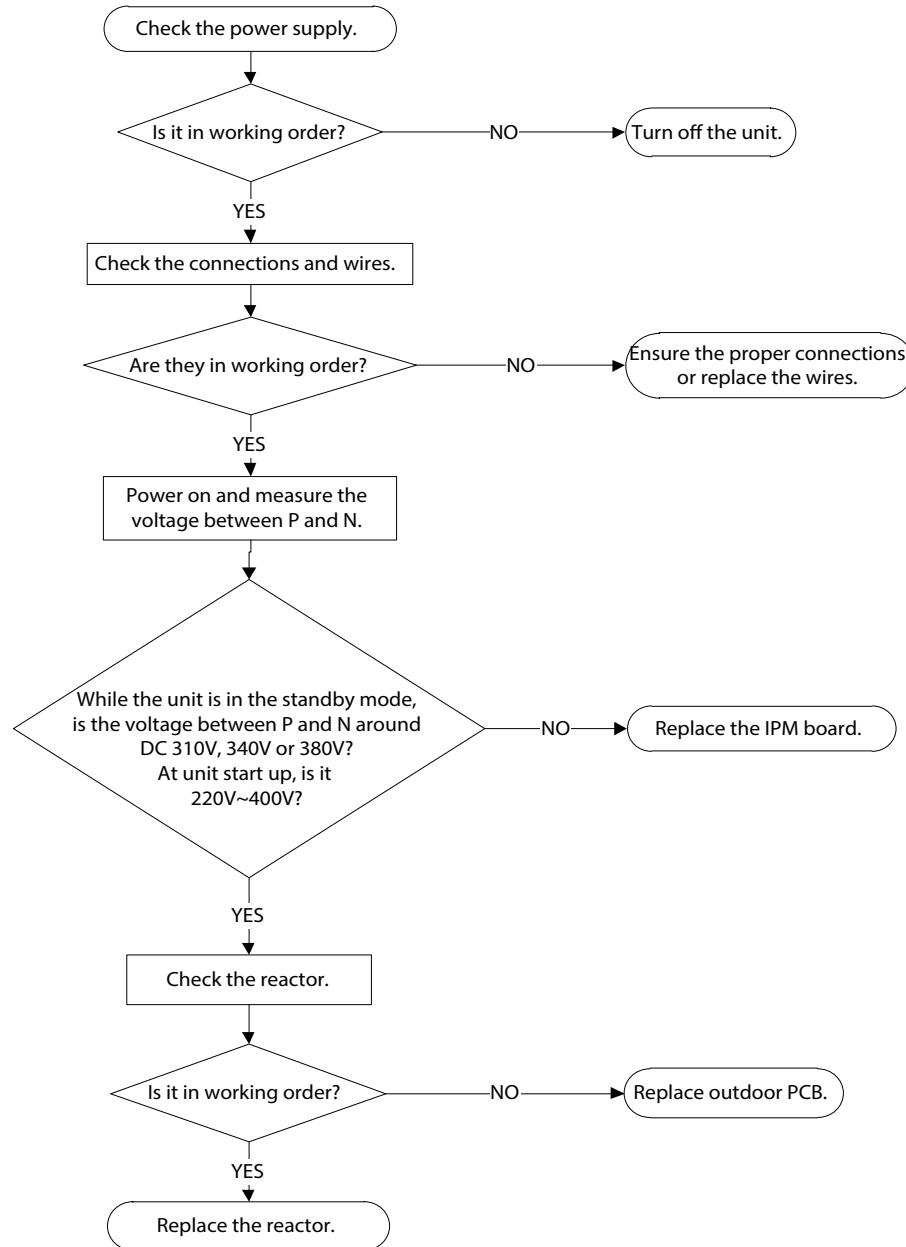

DIAGNOSIS AND SOLUTION (CONT)

Top temperature protection for compressor or High temperature or High pressure protection of IPM module (PC02)

Description: For some models with overload protection, if the sampling voltage is not 5V, the LED displays the failure. If the IPM module temperature is higher than a certain value, the LED displays the failure code. For some models with a high pressure switch, the outdoor pressure switch cuts off the system when the pressure is higher than 4.4 MPa and the LED displays the failure code.

Recommended parts to repair:

- Connection wires
- Outdoor PCB
- IPM module board
- High pressure protector
- System blockages

Troubleshooting

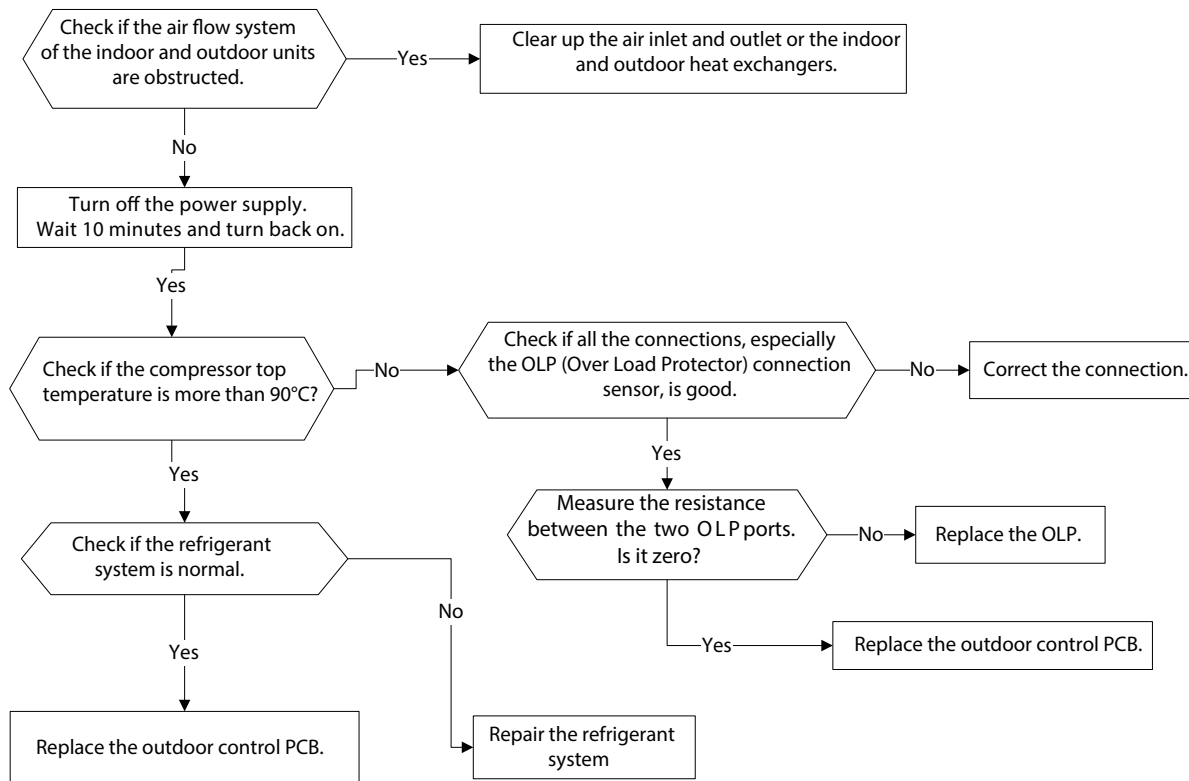

NOTE: For certain models, the outdoor PCB can not be removed separately. In this case, the outdoor electric control box should be replaced as a whole.

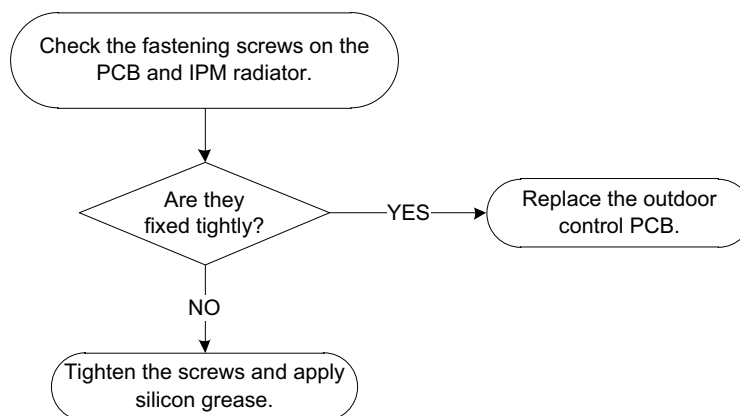

DIAGNOSIS AND SOLUTION (CONT)

Top temperature protection for compressor or High temperature or High pressure protection of IPM module (PC02) (Cont)

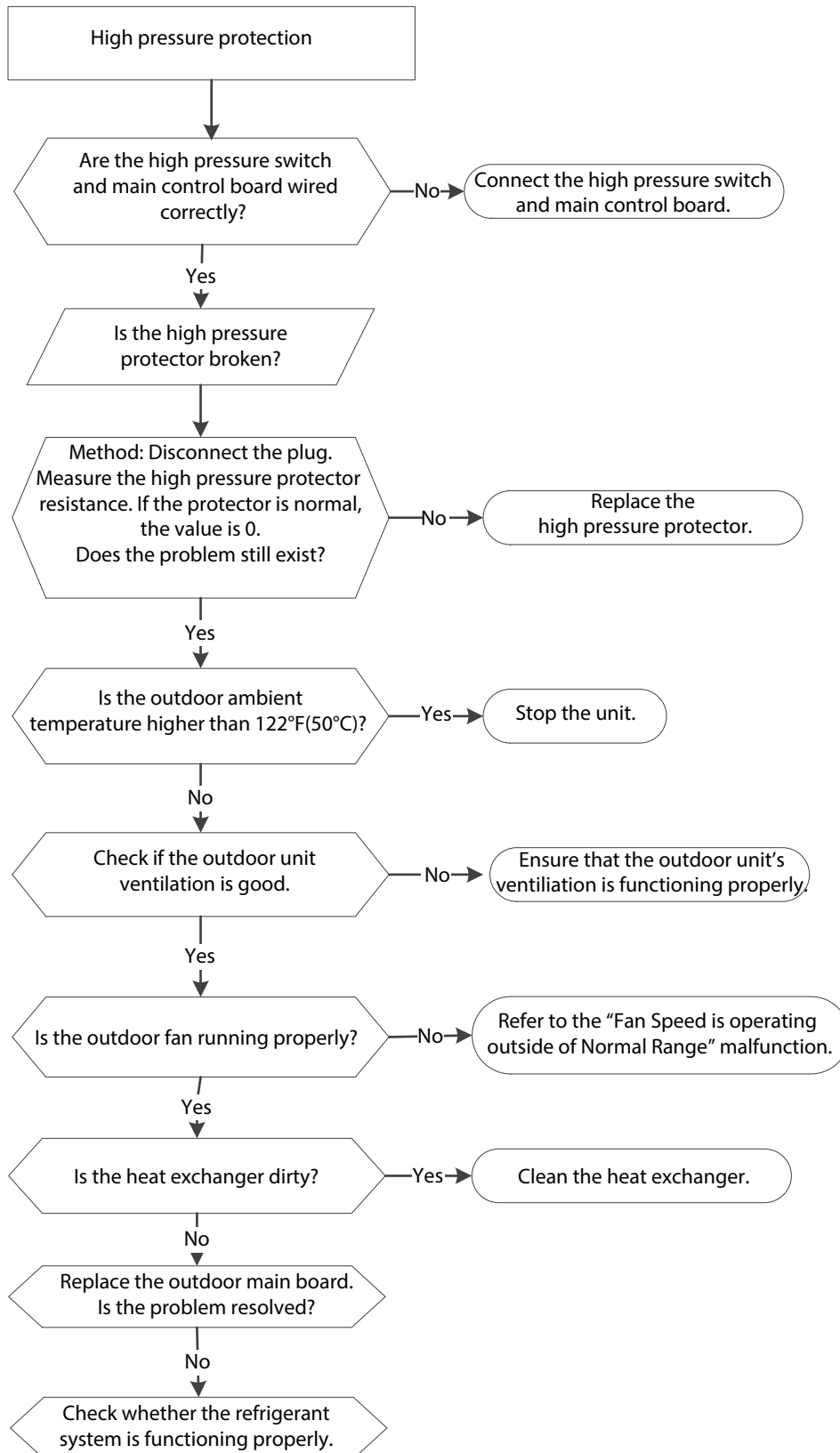

DIAGNOSIS AND SOLUTION (CONT)

Inverter compressor Drive Error (PC04)

Description: An abnormal inverter compressor drive is detected by a special detection circuit, including communication signal detection, voltage detection, compressor rotation and speed signal detection.

Recommended parts to repair:

- Connection wires
- IPM module board
- Outdoor fan assembly
- Compressor
- Outdoor PCB

Troubleshooting

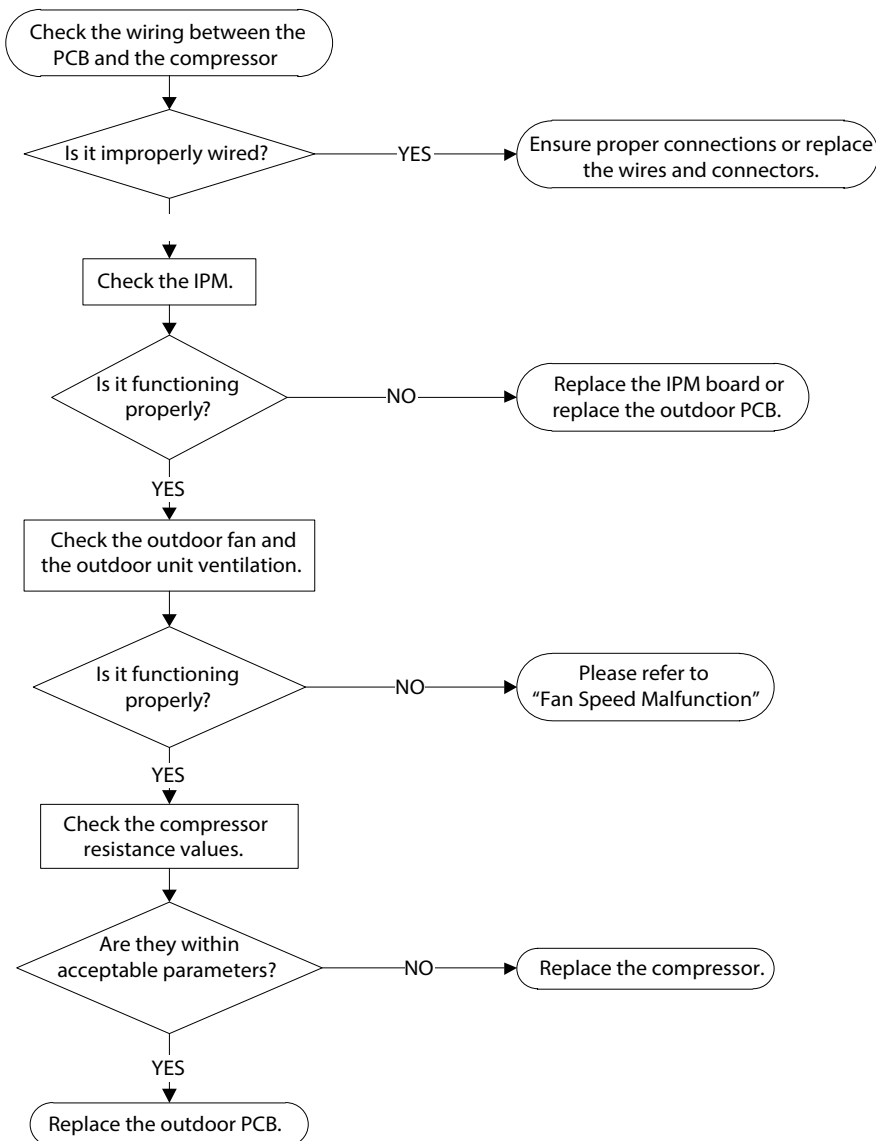

DIAGNOSIS AND SOLUTION (CONT)

Low Pressure Protection (PC03)

Description: The outdoor pressure switch shuts the unit down because the low pressure is lower than 0.13 MPa and the LED displays the failure code.

Recommended parts to repair:

- Connection wires
- Outdoor PCB
- Low pressure protector
- Refrigerant

Troubleshooting

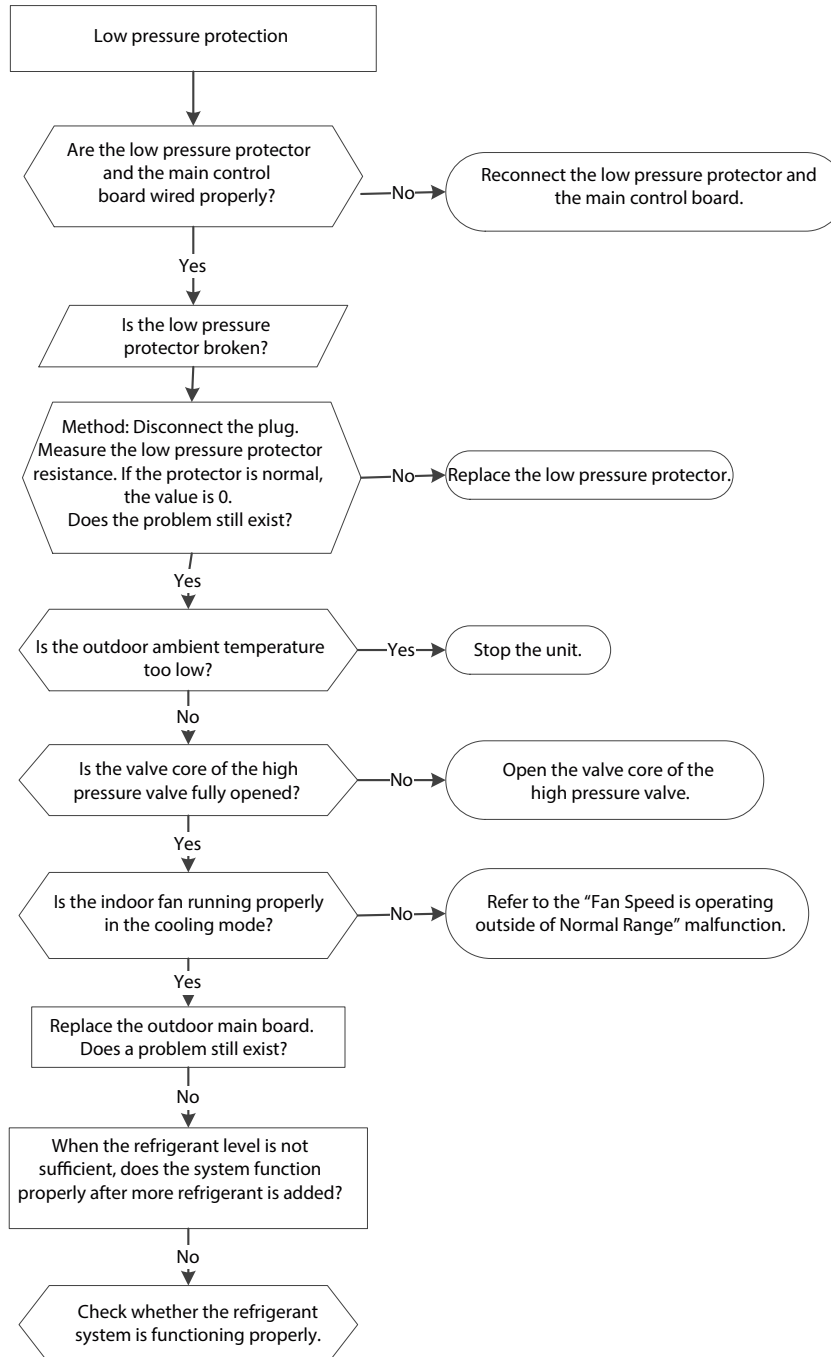

DIAGNOSIS AND SOLUTION (CONT)

Indoor Units Mode Conflict (match with multi outdoor unit)

Description: The indoor units cannot operate in the **COOLING** mode and **HEATING** mode simultaneously. The **HEATING** mode is the priority.

Examples:

- If indoor unit A is operating in the **COOLING** mode or the **FAN** mode, and indoor unit B is set to the **HEATING** mode, unit A will power off and unit B will continue to operate in the **HEATING** mode.
- If indoor unit A is operating in the **HEATING** mode and indoor unit B is set to the **COOLING** mode or fan mode, unit B will change to **STANDBY** mode and unit A will not change modes.

	Cooling Mode	Heating Mode	Fan	Off
Cooling Mode	No	Yes	No	No
Heating Mode	Yes	No	Yes	No
Fan	No	Yes	No	No
Off	No	No	No	No

NOTE:

No: No mode conflict

Yes: Mode conflict

DIAGNOSIS AND SOLUTION (CONT)

Communication Error Between Outdoor Main Chip and Compressor Driven Chip (PC40)

Description: The main chip cannot detect the compressor driven chip.

Recommended parts to repair:

- Outdoor PCB
- Electric control box

Troubleshooting

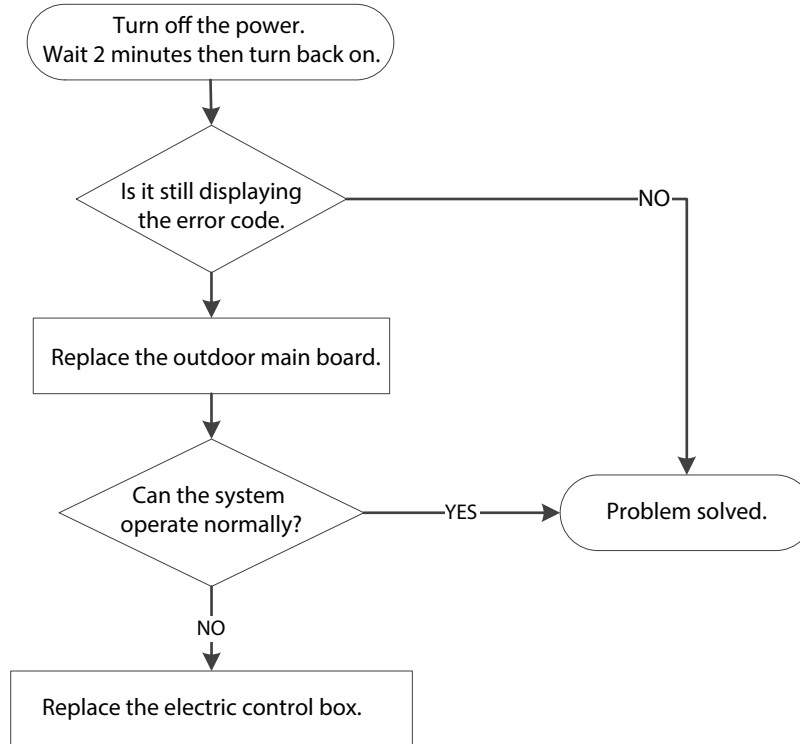

Check Procedures

Temperature Sensor Check



WARNING

Be sure to turn off all power supplies or disconnect all wires to avoid shock.

Operate after the compressor and coil have returned to a normal temperature in case of injury.

1. Disconnect the temperature sensor from PCB.
2. Measure the sensor's resistance value using a multi-meter.
3. Check the corresponding temperature sensor's resistance value table.

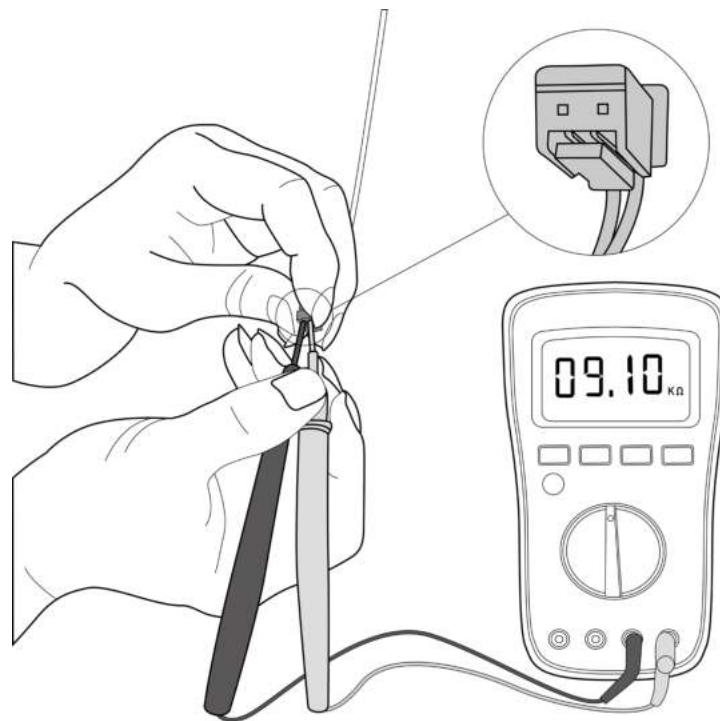

Fig. 41 — Test

Compressor Check

1. Disconnect the compressor power cord from the outdoor PCB.
2. Measure the resistance value of each winding using a multi-meter.
3. Check the resistance value of each winding in Tables 21 - 21.

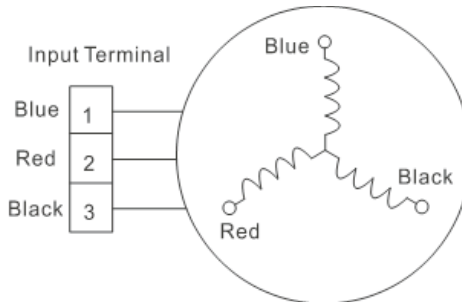

Table 21 — Resistance Value

Resistance Value	KSK103D33UEZ3(YJ)	KTM240D43UKT	KTN110D42UFZ	KTF250D22UMT
Blue-Red	2.13Ω	1.03Ω	1.82Ω	0.75Ω
Blue-Black				
Red-Black				

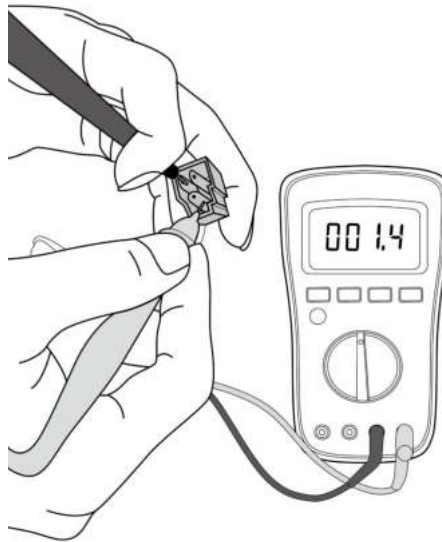

Fig. 42 — Testing

IPM Continuity Check



WARNING

ELECTRICAL SHOCK HAZARD

Electricity remains in the capacitors even when the power is off.

Ensure the capacitors are fully discharged before troubleshooting.

1. Turn off the outdoor unit and disconnect the power supply.
2. Discharge the electrolytic capacitors and ensure all energy has been discharged.
3. Disassemble the outdoor PCB or disassemble the IPM board.
4. Measure the resistance valve between P and U(V,W,N); U(V,W) and N.

Digital Tester		Resistance Valve	Digital Tester		Resistance Valve
(+) Red	(-) Black		(+) Red	(-) Black	
P	N	∞ (Several M Ω)	U	N	∞ (Several M Ω)
	U		V		
	V		W		
	W		-		

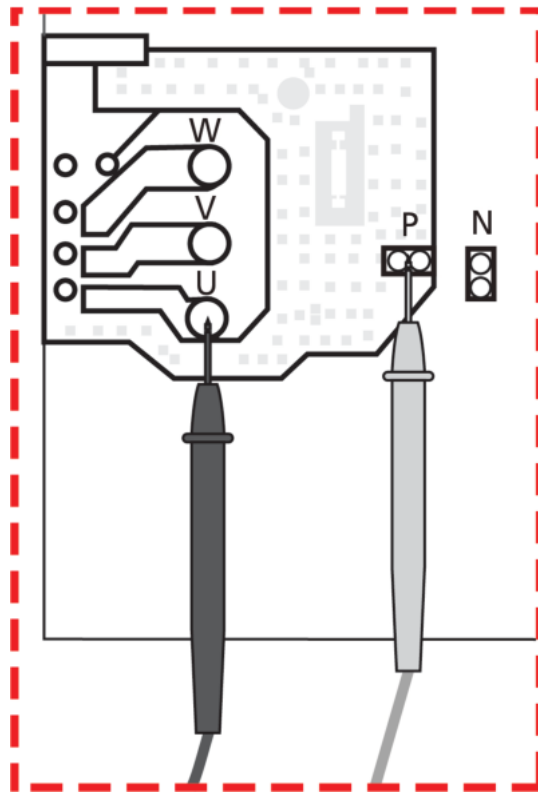

Fig. 43 — Testing

4 - Way Valve Check

1. Power on, use a digital tester to measure the voltage; when the unit operates in the **COOLING** mode, the voltage is 0V. If the voltage value is not in range, the PCB is faulty and needs to be replaced.

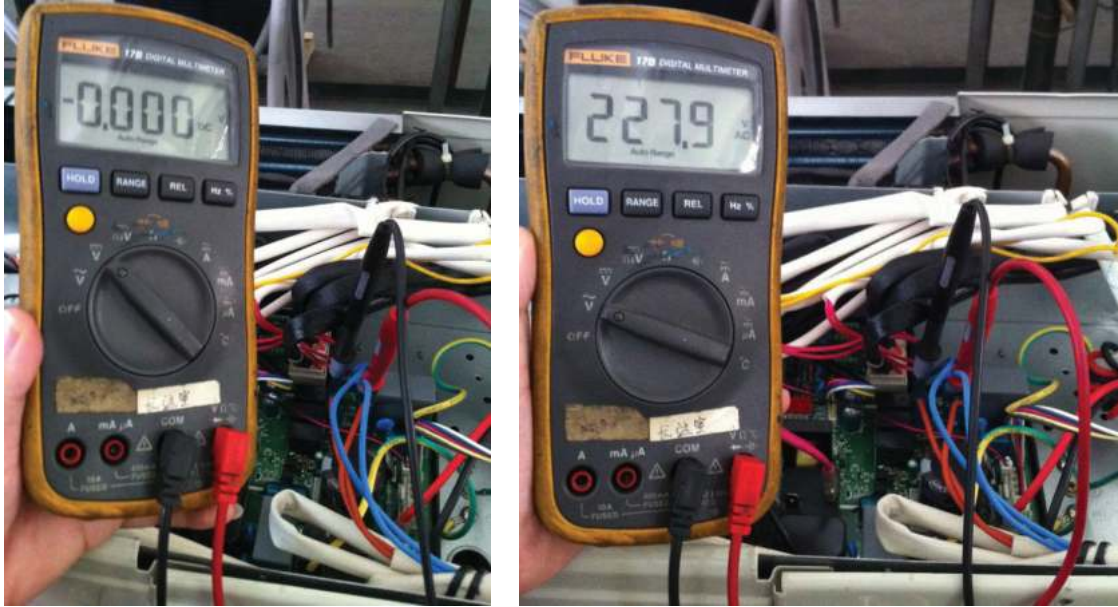

Fig. 44 — Measure the voltage

2. Turn off the power, use a digital tester to measure the resistance. The value should be 1.8~2.5 K Ω .

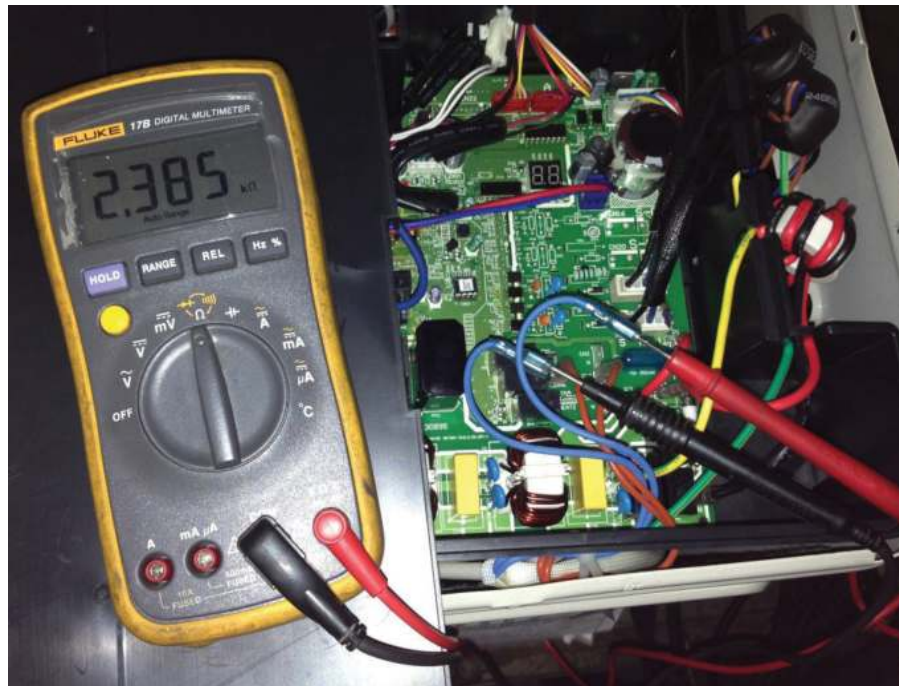

Fig. 45 — Use a digital tester to measure resistance

EXV Check

⚠

WARNING

ELECTRICAL SHOCK HAZARD
Electricity remains in the capacitors even when the power is off.
Ensure the capacitors are fully discharged before troubleshooting.

1. Disconnect the connector from the outdoor PCB.
2. Measure the resistance value of each winding using a multi-meter.
3. Check the resistance value of each winding in Table 22.

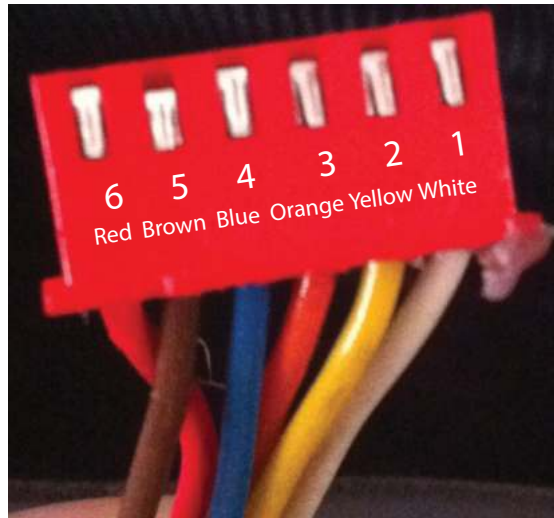

Fig. 46 — EXV Check

Table 22 — Winding Colors

LEAD WINDING COLOR	NORMAL VALUE
Red-Blue	About 50Ω
Red-Yellow	
Brown-Orange	
Brown-White	

Main Parts Check

1. Temperature sensor checking

Disconnect the temperature sensor from PCB, measure the resistance value with a tester.

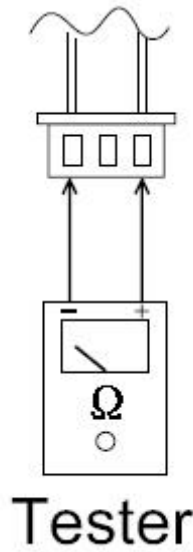

Fig. 47 —Tester

Temperature sensors

- Room temp. (T1) sensor,
 - Indoor coil temp. (T2) sensor,
 - Outdoor coil temp. (T3) sensor,
 - Outdoor ambient temp. (T4) sensor,
 - Compressor discharge temp. (T5) sensor.
- Measure the resistance value of each winding by using the multi-meter.

Pressure on Service Port

Table 23 — Cooling Chart (R410A)

°F(°C)	ODU(DB)		IDU(DB/WB)								
	0 (-17)	5 (-15)	15 (-9.44)	45 (7.22)	75 (23.89)	85 (29.44)	95 (35)	105 (40.56)	115 (46.11)	120 (48.89)	
BAR	70/59 (21.11/15)	6.4	6.5	7.3	8.0	8.2	7.8	8.1	8.6	10.1	10.6
	75/63 (23.89/17.22)	6.7	6.8	7.9	8.6	8.6	8.3	8.7	9.1	10.7	11.2
	80/67 (26.67/19.44)	7.1	7.2	8.5	9.5	9.3	8.9	9.1	9.6	11.2	11.9
	90/73 (32.22/22.78)	7.7	7.8	9.6	10.5	10.3	9.5	10.0	10.6	12.4	13.0
PSI	70/59 (21.11/15)	93	94	106	116	119	113	117	125	147	154
	75/63 (23.89/17.22)	97	99	115	125	124	120	126	132	155	162
	80/67 (26.67/19.44)	103	104	123	138	135	129	132	140	162	173
	90/73 (32.22/22.78)	112	113	139	152	149	138	145	154	180	189
MPa	70/59 (21.11/15)	0.64	0.65	0.73	0.8	0.82	0.78	0.81	0.86	1.01	1.06
	75/63 (23.89/17.22)	0.67	0.68	0.79	0.86	0.86	0.83	0.87	0.91	1.07	1.12
	80/67 (26.67/19.44)	0.71	0.72	0.85	0.95	0.93	0.89	0.91	0.96	1.12	1.19
	90/73 (32.22/22.78)	0.77	0.78	0.96	1.05	1.03	0.95	1	1.06	1.24	1.3

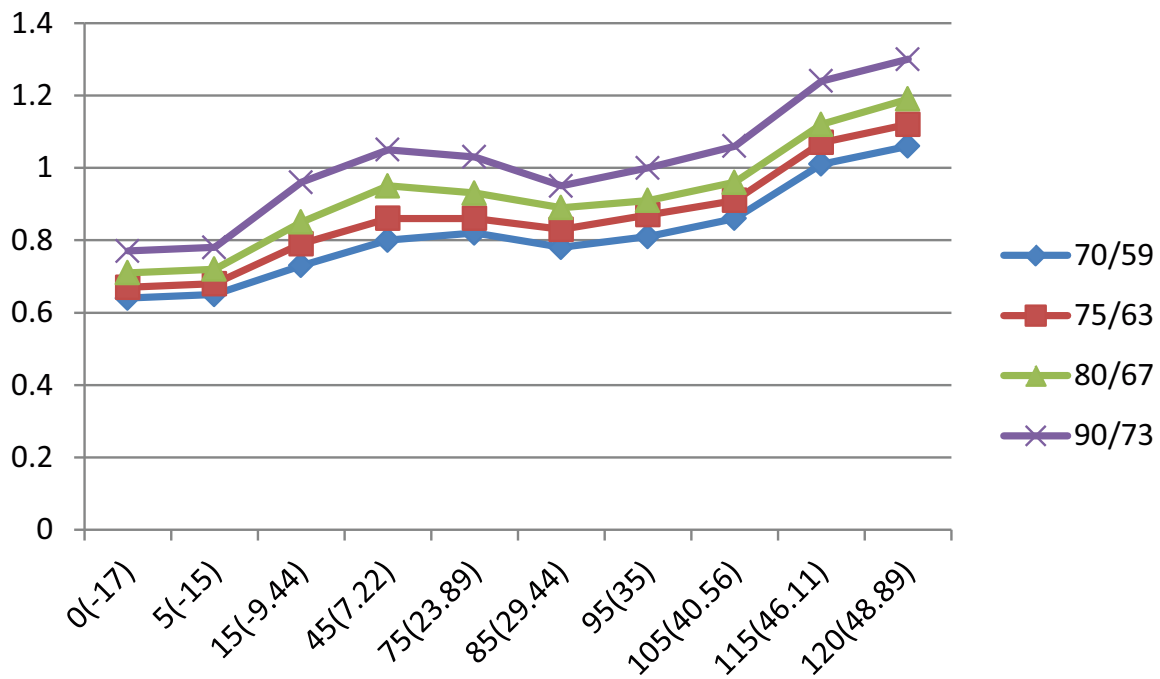

Fig. 48 — Cooling Chart

Pressure on Service Port (Cont)

Table 24 — Heating Chart (R410A)

°F(°C)	ODU(DB/WB)	57/53 (13.89/11.67)	47/43 (8.33/6.11)	37/33 (2.78/0.56)	27/23 (-2.78/-5)	17/13 (-8.33/-10.56)	0/-2 (-17/-19)	-17/-18 (-27/-28)
	IDU(DB)							
BAR	55(12.78)	30.3	28.5	25.3	22.8	20.8	18.5	16.5
	65(18.33)	32.5	30.0	26.6	25.4	23.3	20.5	19.0
	75(23.89)	33.8	31.5	27.8	26.3	24.9	21.5	20.0
PSI	55(12.78)	439	413	367	330	302	268	239
	65(18.33)	471	435	386	368	339	297	276
	75(23.89)	489	457	403	381	362	312	290
MPa	55(12.78)	3.03	2.85	2.53	2.28	2.08	1.85	1.65
	65(18.33)	3.25	3.00	2.66	2.54	2.33	2.05	1.90
	75(23.89)	3.38	3.15	2.78	2.63	2.49	2.15	2.00

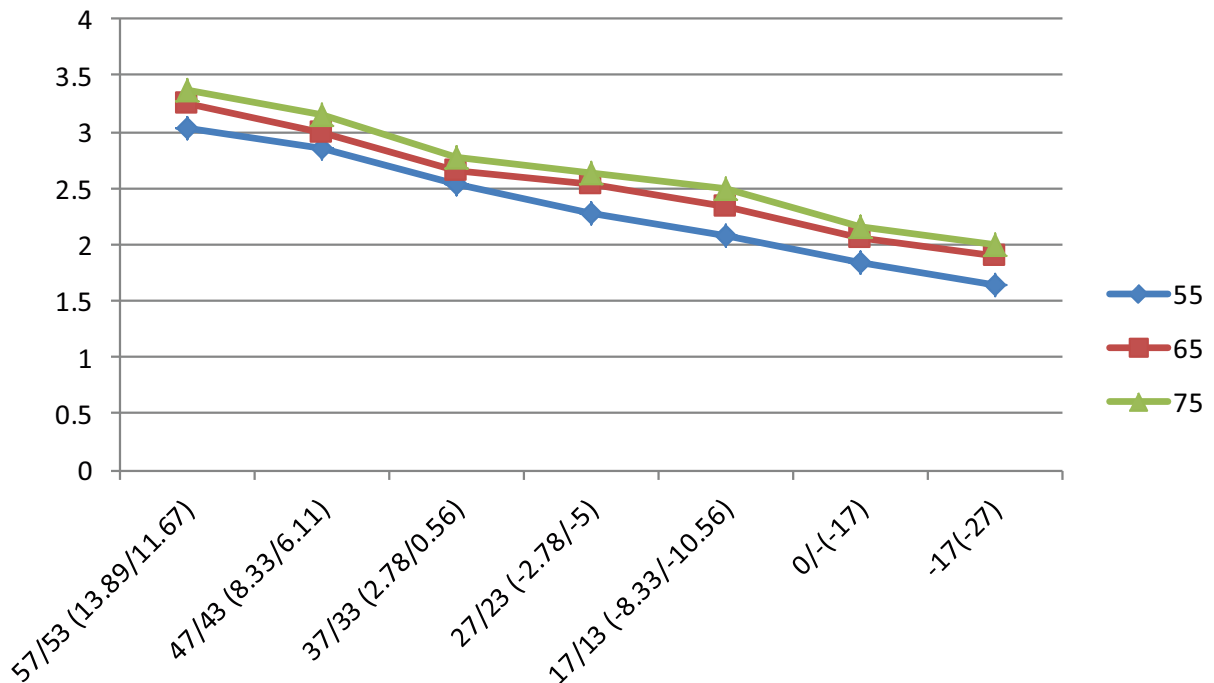

Fig. 49 — Heating Chart

System Pressure

Table 25 — System Pressure Table-R410A

PRESSURE			TEMPERATURE		PRESSURE			TEMPERATURE	
Kpa	bar	PSI	°C	°F	Kpa	bar	PSI	°C	°F
100	1	14.5	-51.623	-60.921	2350	23.5	340.75	38.817	101.871
150	1.5	21.75	-43.327	-45.989	2400	24	348	39.68	103.424
200	2	29	-36.992	-34.586	2450	24.5	355.25	40.531	104.956
250	2.5	36.25	-31.795	-25.231	2500	25	362.5	41.368	106.462
300	3	43.5	-27.351	-17.232	2550	25.5	369.75	42.192	107.946
350	3.5	50.75	-23.448	-10.206	2600	26	377	43.004	109.407
400	4	58	-19.953	-3.915	2650	26.5	384.25	43.804	110.847
450	4.5	65.25	-16.779	1.798	2700	27	391.5	44.592	112.266
500	5	72.5	-13.863	7.047	2750	27.5	398.75	45.37	113.666
550	5.5	79.75	-11.162	11.908	2800	28	406	46.136	115.045
600	6	87	-8.643	16.444	2850	28.5	413.25	46.892	116.406
650	6.5	94.25	-6.277	20.701	2900	29	420.5	47.638	117.748
700	7	101.5	-4.046	24.716	2950	29.5	427.75	48.374	119.073
750	7.5	108.75	-1.933	28.521	3000	30	435	49.101	120.382
800	8	116	0.076	32.137	3050	30.5	442.25	49.818	121.672
850	8.5	123.25	1.993	35.587	3100	31	449.5	50.525	122.945
900	9	130.5	3.826	38.888	3150	31.5	456.75	51.224	124.203
950	9.5	137.75	5.584	42.052	3200	32	464	51.914	125.445
1000	10	145	7.274	45.093	3250	32.5	471.25	52.596	126.673
1050	10.5	152.25	8.901	48.022	3300	33	478.5	53.27	127.886
1100	11	159.5	10.471	50.848	3350	33.5	485.75	53.935	129.083
1150	11.5	166.75	11.988	53.578	3400	34	493	54.593	130.267
1200	12	174	13.457	56.223	3450	34.5	500.25	55.243	131.437
1250	12.5	181.25	14.879	58.782	3500	35	507.5	55.885	132.593
1300	13	188.5	16.26	61.268	3550	35.5	514.75	56.52	133.736
1350	13.5	195.75	17.602	63.684	3600	36	522	57.148	134.866
1400	14	203	18.906	66.031	3650	36.5	529.25	57.769	135.984
1450	14.5	210.25	20.176	68.317	3700	37	536.5	58.383	137.089
1500	15	217.5	21.414	70.545	3750	37.5	543.75	58.99	138.182
1550	15.5	224.75	22.621	72.718	3800	38	551	59.591	139.264
1600	16	232	23.799	74.838	3850	38.5	558.25	60.185	140.333
1650	16.5	239.25	24.949	76.908	3900	39	565.5	60.773	141.391
1700	17	246.5	26.074	78.933	3950	39.5	572.75	61.355	142.439
1750	17.5	253.75	27.174	80.913	4000	40	580	61.93	143.474
1800	18	261	28.251	82.852	4050	40.5	587.25	62.499	144.498
1850	18.5	268.25	29.305	84.749	4100	41	594.5	63.063	145.513
1900	19	275.5	30.338	86.608	4150	41.5	601.75	63.62	146.516
1950	19.5	282.75	31.351	88.432	4200	42	609	64.172	147.510
2000	20	290	32.344	90.219	4250	42.5	616.25	64.719	148.494
2050	20.5	297.25	33.319	91.974	4300	43	623.5	65.259	149.466
2100	21	304.5	34.276	93.697	4350	43.5	630.75	65.795	150.431
2150	21.5	311.75	35.215	95.387	4400	44	638	66.324	151.383
2200	22	319	36.139	97.050	4450	44.5	645.25	66.849	152.328
2250	22.5	326.25	37.047	98.685	4500	45	652.5	67.368	153.262
2300	23	333.5	37.939	100.290					

DISASSEMBLY INSTRUCTIONS

Outdoor Unit Sizes 9-12K (115V) Panel Plate

NOTE: This part is for reference only and the photos may differ from your actual unit.

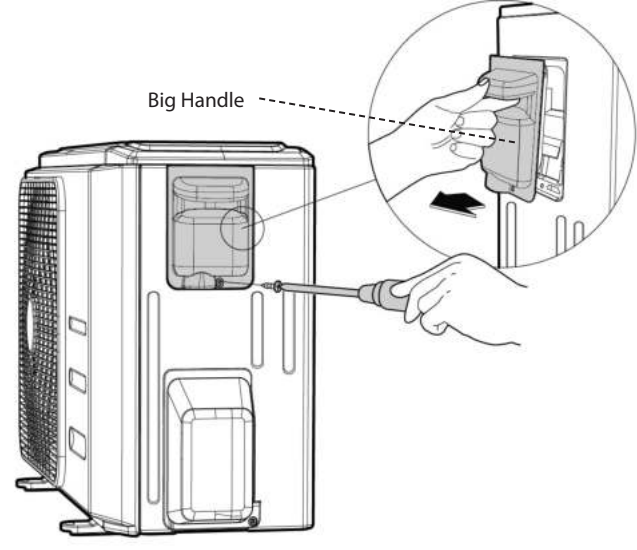
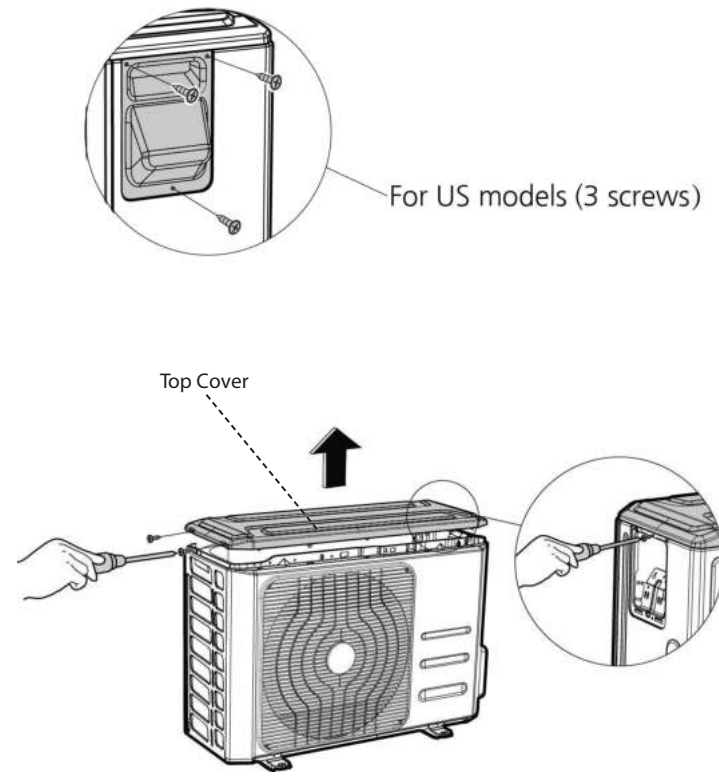
Procedure	Illustration
<p>1) Turn off the air conditioner and the power breaker.</p> <p>2) Remove the big handle screw (1) and then remove the big handle.</p>	 <p>Big Handle</p>
<p>3) Remove the top cover screws (3) and then remove the top cover. One of the screws is located under the big handle.</p>	 <p>Top Cover</p> <p>For US models (3 screws)</p>

Procedure

Illustration

- 4) Remove the front panel screws (6) and then remove the front panel.

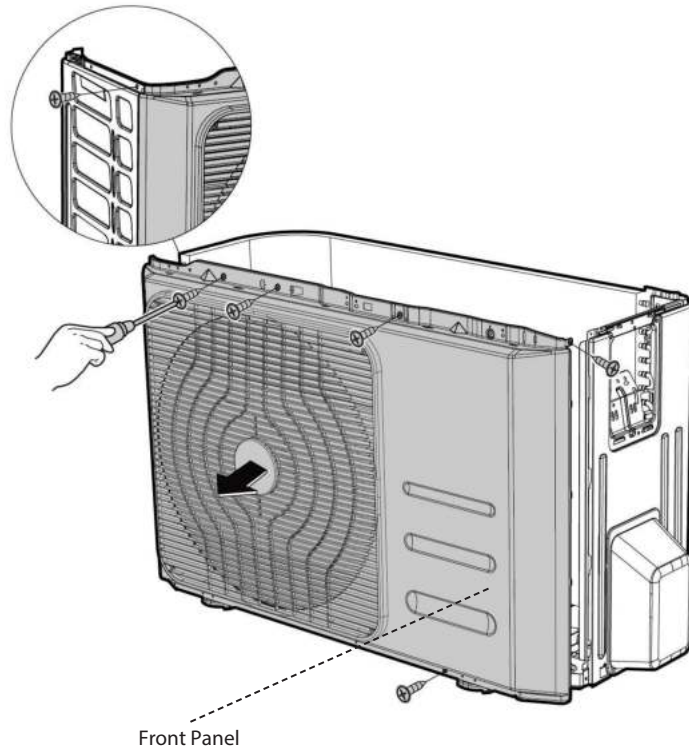

- 5) Remove the water collecting cover screws (2) and remove the water collecting cover.

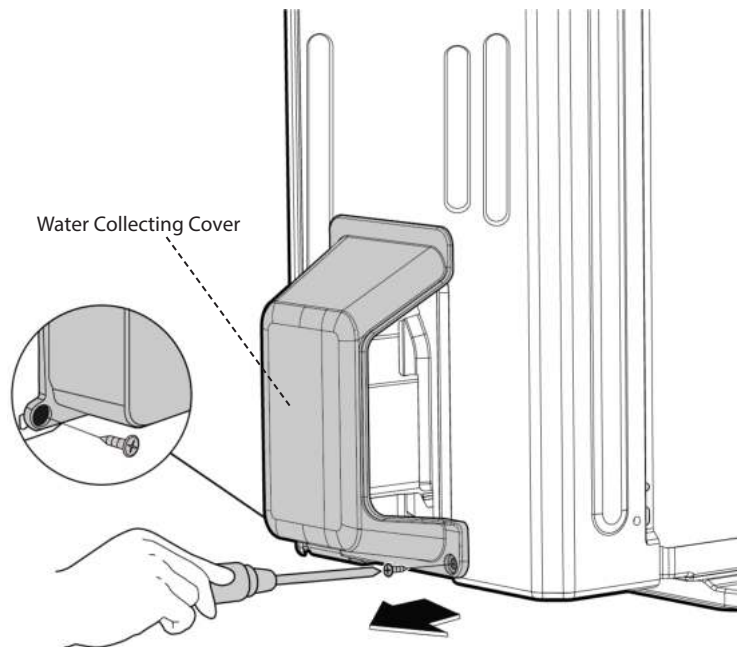

Procedure

Illustration

6) Remove the rear net screws (2) and then remove the rear net (for some models).

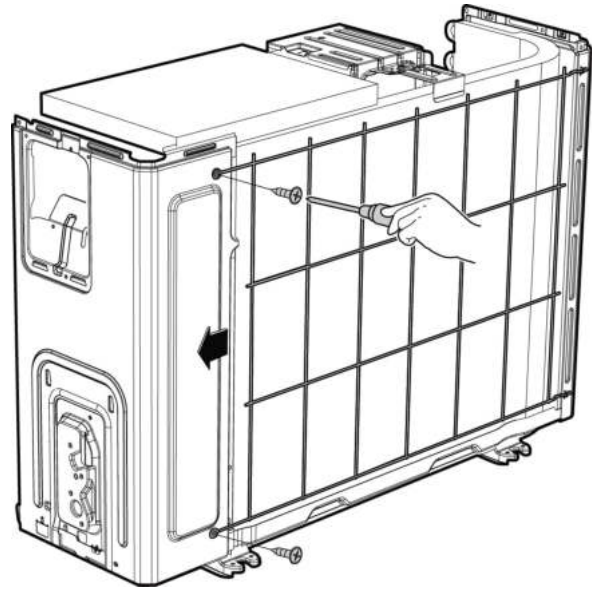

7) Remove the right panel screws (6) and then remove the right panel.

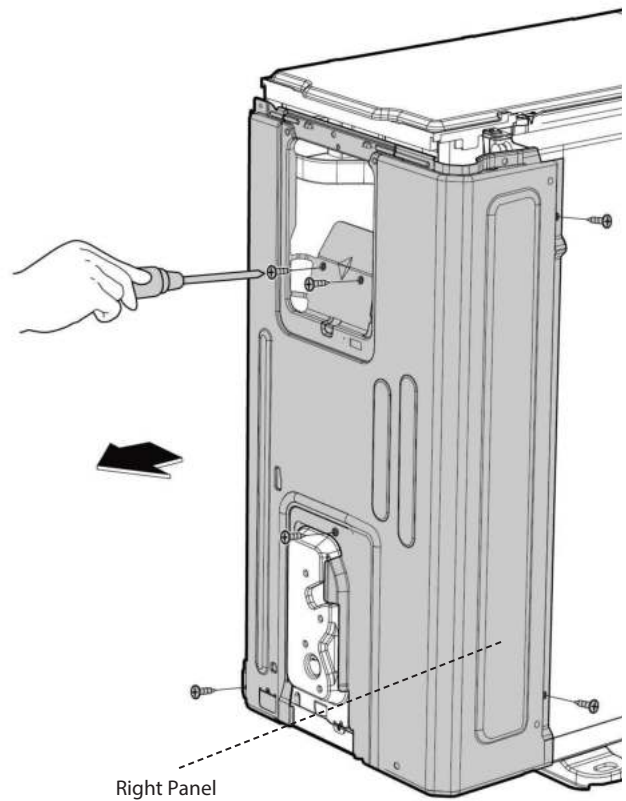

Procedure

- 1) Turn off the air conditioner and the power breaker.
- 2) Remove the big handle screw (1) and then remove the big handle.

Illustration

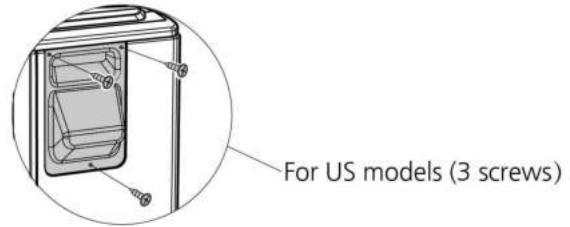
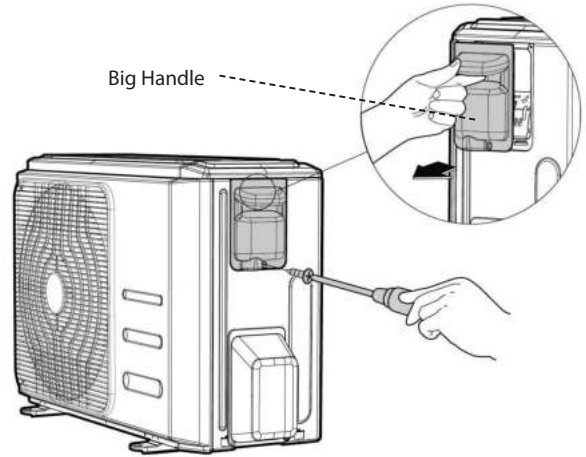

- 3) Remove the top cover screws (3) and then remove the top cover. One of the screws is located underneath the big handle.

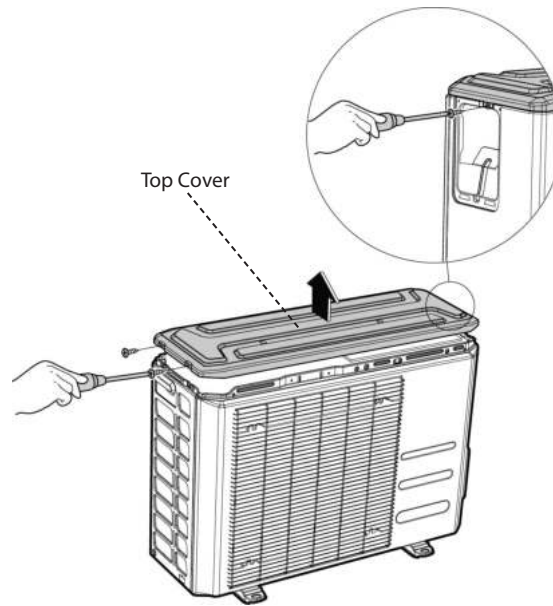

Procedure

Illustration

- 4) Remove the front panel screws (7) and then remove the front panel.

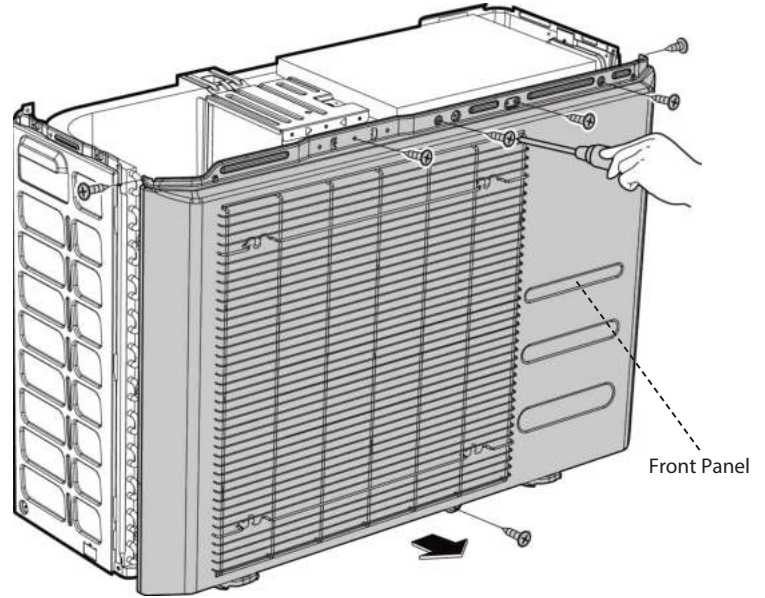

- 5) Remove the water collecting cover screws (2) then remove the water collecting cover.

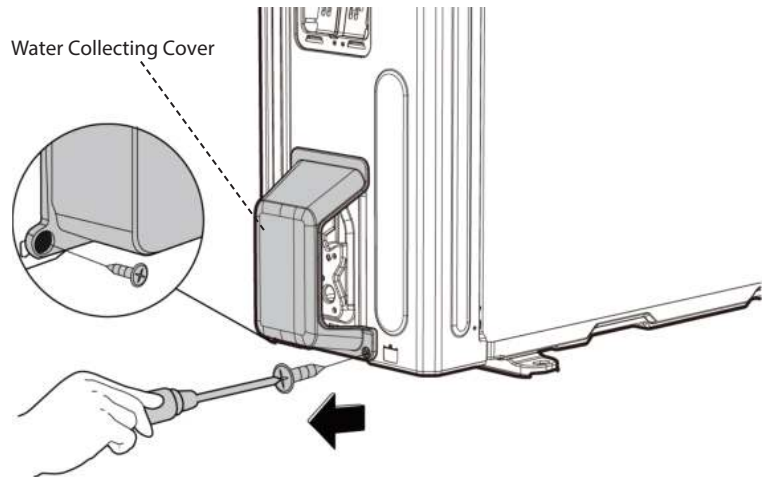

Procedure

Illustration

- 6) Remove the rear net screws and then remove the rear net (2 screws) (for some models).

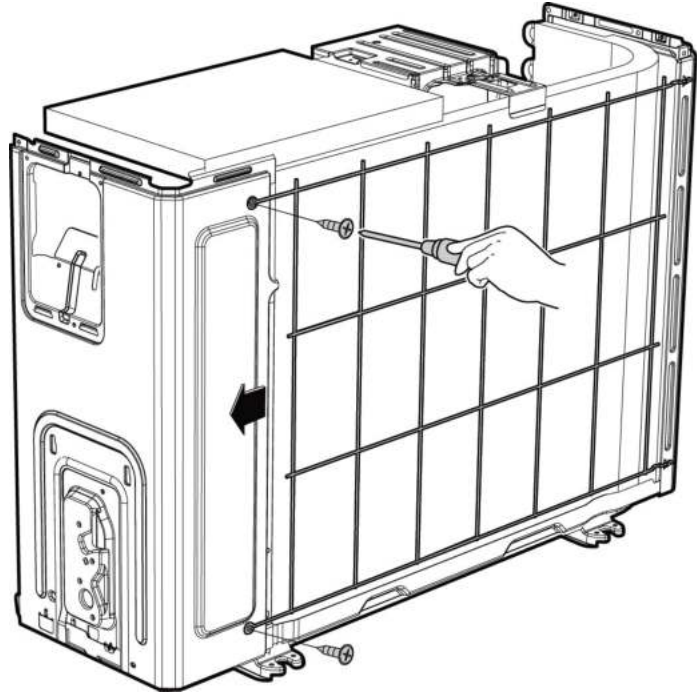

- 7) Remove the right panel screws (2) and then remove the right panel.

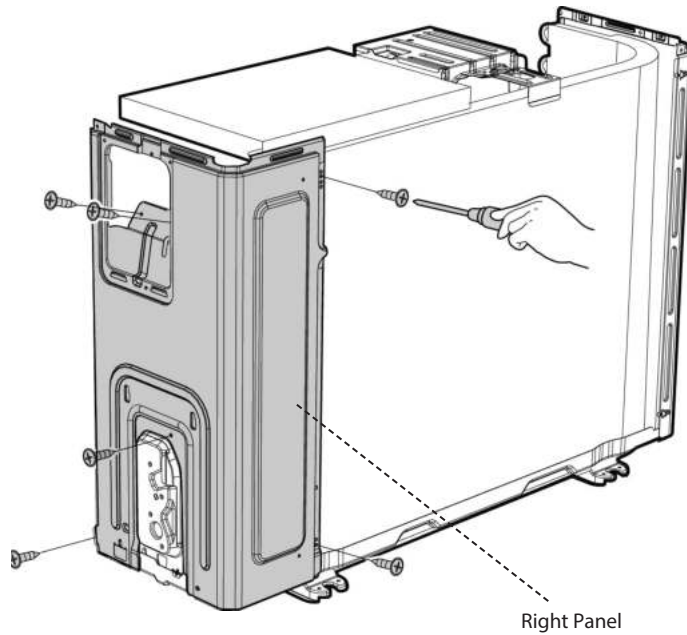

Procedure

- 1) Turn off the air conditioner and the power breaker.
- 2) Remove the big handle screw (1) and then remove the big handle.

Illustration

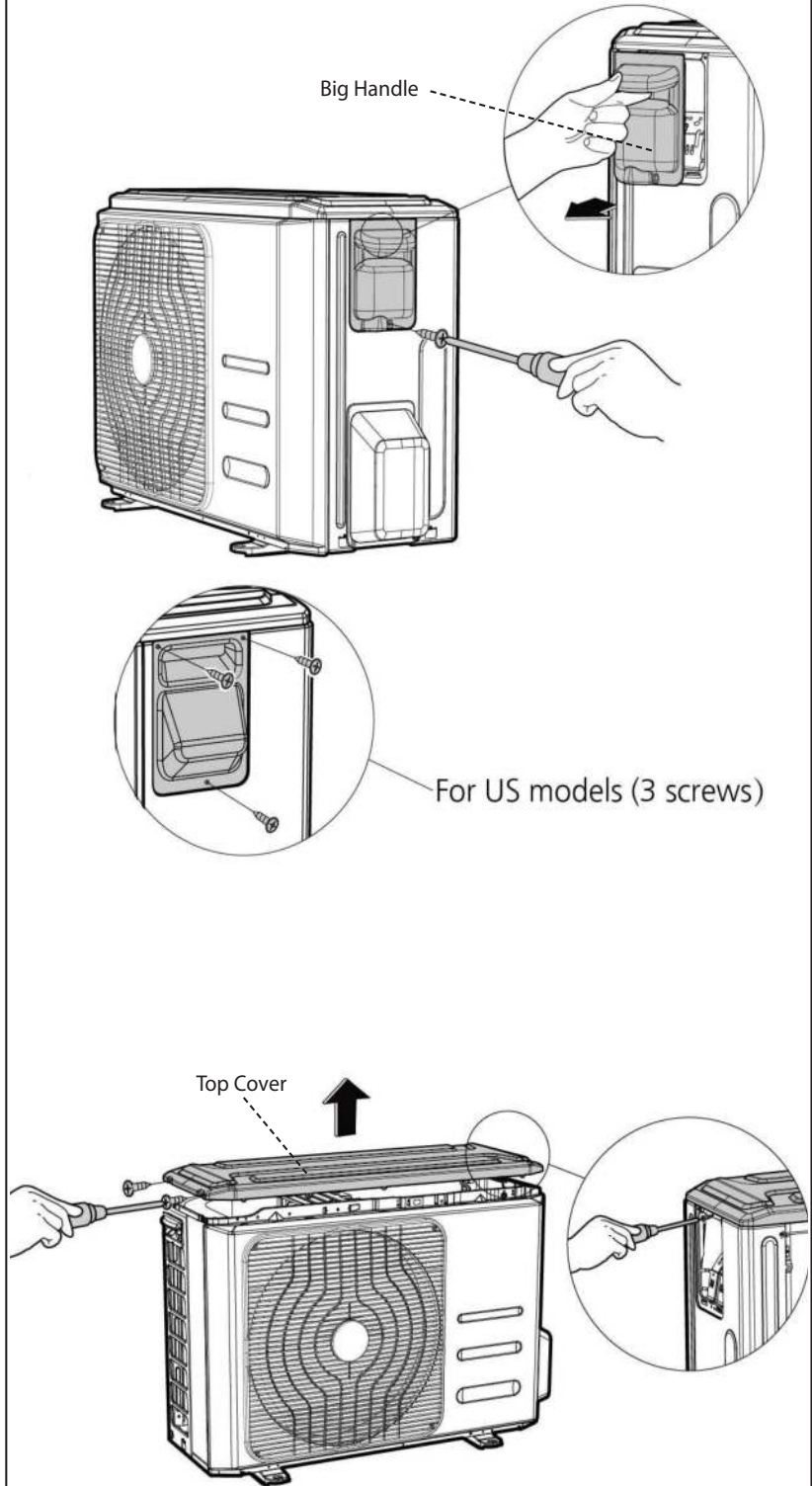

- 3) Remove the top cover screws (3) and then remove the top cover. One of the screws is located underneath the big handle.

Procedure

Illustration

- 4) Remove the front panel screws (8) and then remove the front panel.

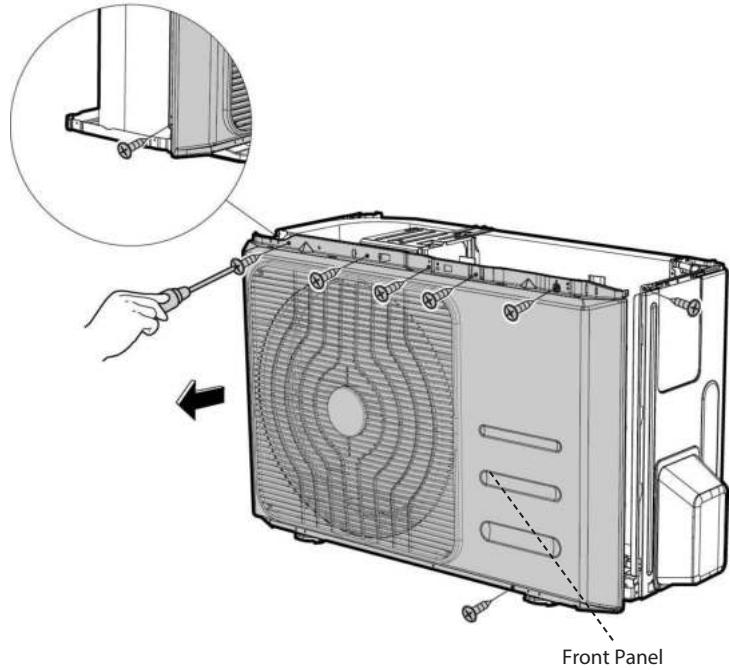

- 5) Remove the water collecting cover screws and then remove the water collecting cover.

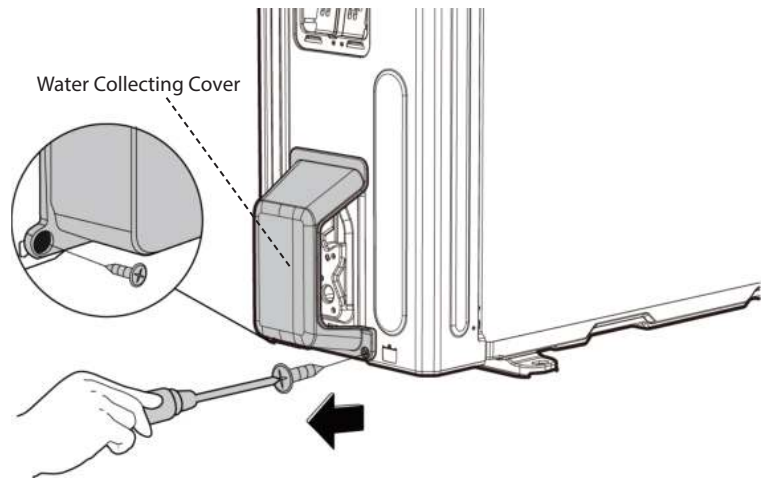

Procedure

Illustration

6) Remove the rear net screws (2) and then remove the rear net.

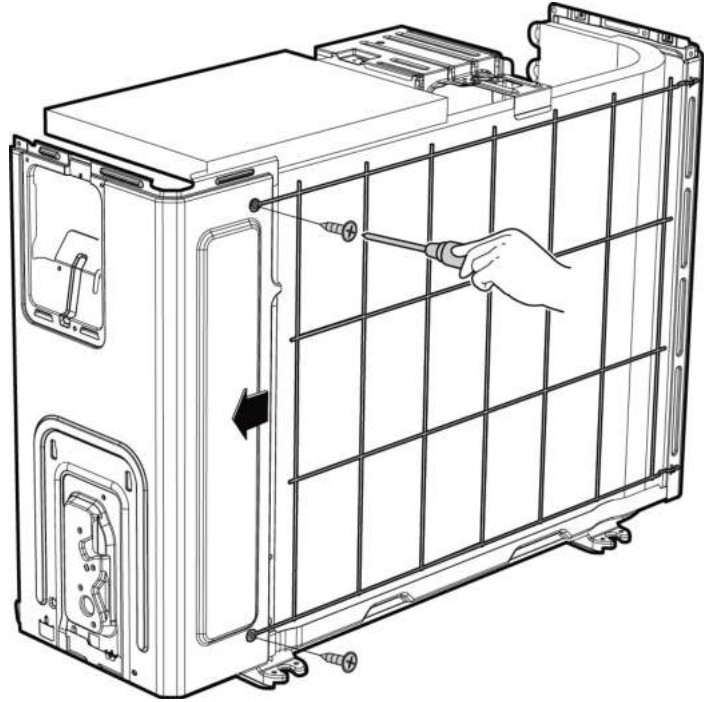

7) Remove the right panel screws (5) and then remove the right panel.

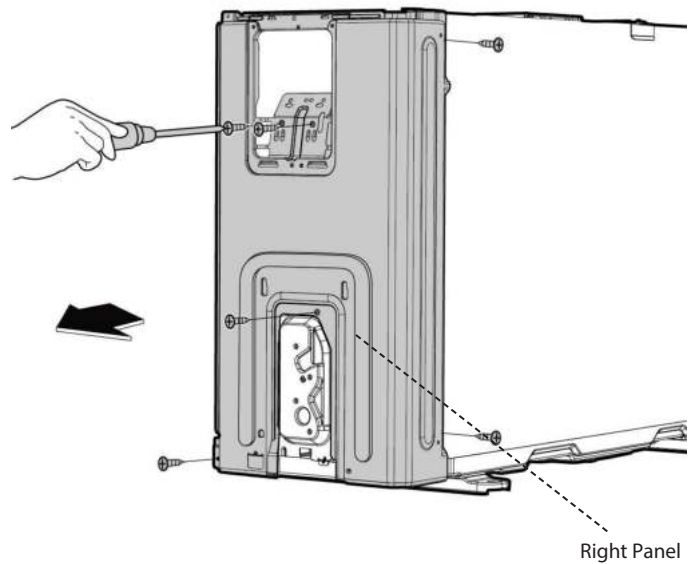

Outdoor Unit Size 24K (208-230V)

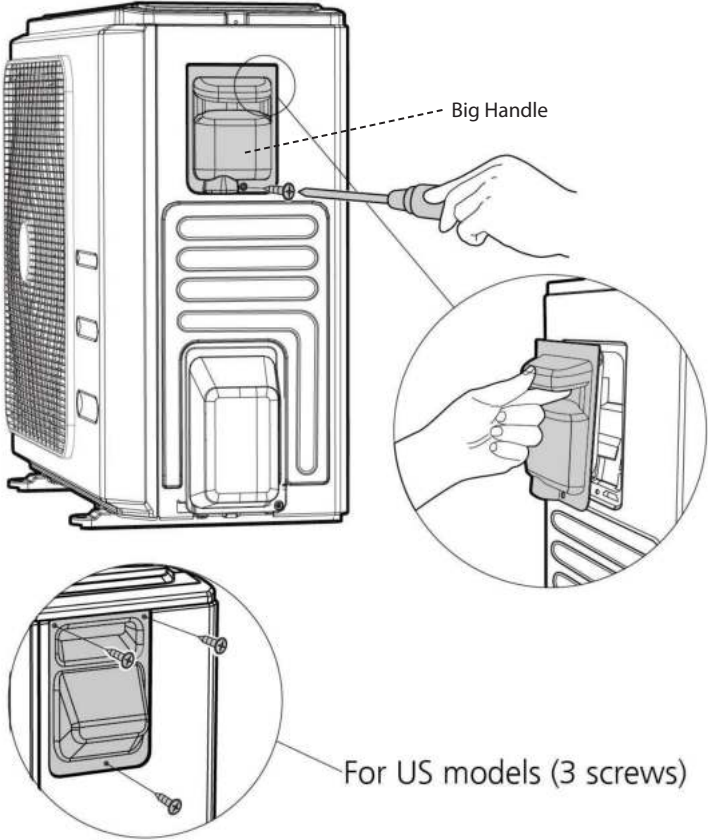
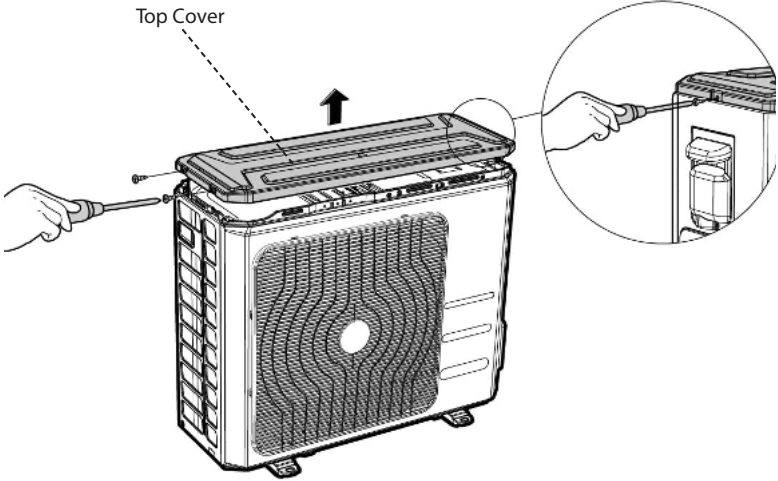
Procedure	Illustration
<p>1) Turn off the air conditioner and the power breaker.</p> <p>2) Remove the big handle screw (1) and then remove the big handle.</p>	 <p>The illustration shows a hand using a screwdriver to remove a screw from the top of the outdoor unit. A callout labeled "Big Handle" points to the handle being removed. A circular inset shows a hand pulling the handle away from the unit. Another circular inset shows the handle being removed from the unit, with the text "For US models (3 screws)" pointing to the handle's attachment points.</p>
<p>3) Remove the top cover screws(3) and then remove the top cover. One of the screws is located under the big handle.</p>	 <p>The illustration shows a hand using a screwdriver to remove a screw from the top cover of the outdoor unit. A callout labeled "Top Cover" points to the top cover. An upward arrow indicates the direction to lift the top cover. A circular inset shows a hand using a screwdriver to remove a screw from the top cover.</p>

Procedure

- 4) Remove the front panel screws (7) and then remove the front panel.

Illustration

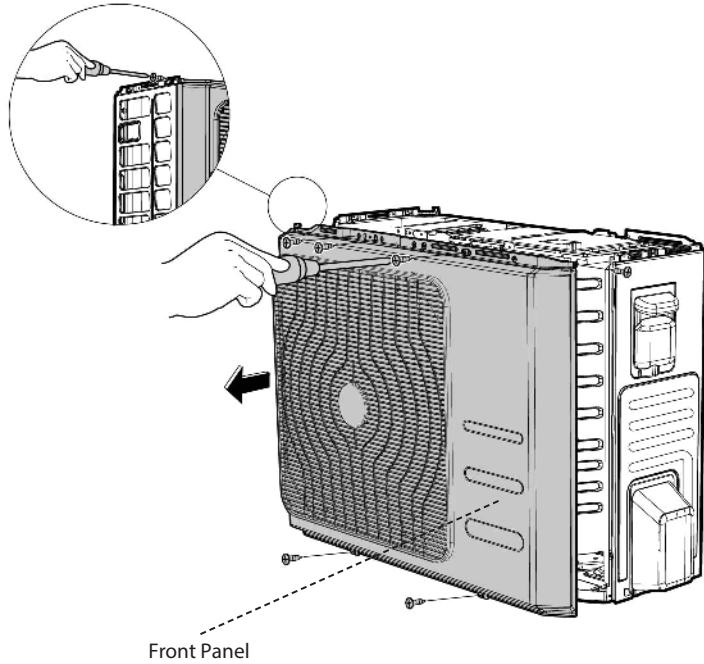

- 5) Remove the water collecting cover screws (2) and then remove the water collecting cover.

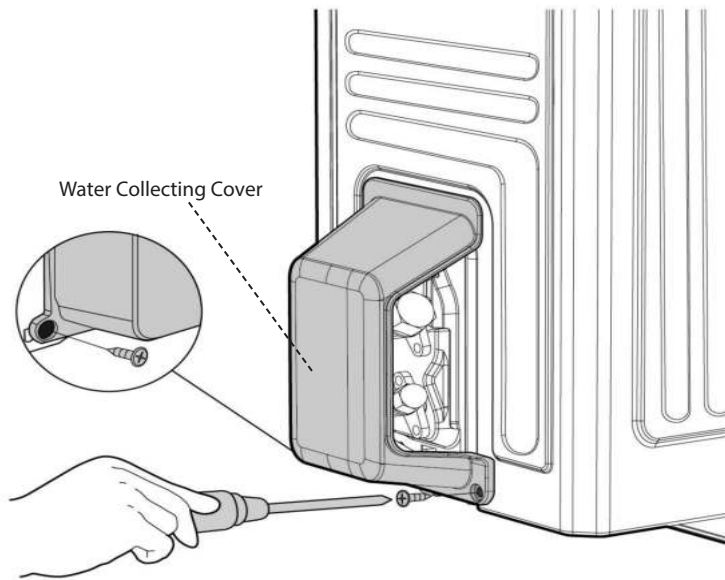

Procedure

Illustration

6) Remove the rear net screws and then remove the rear net (2 screws) (for some models).

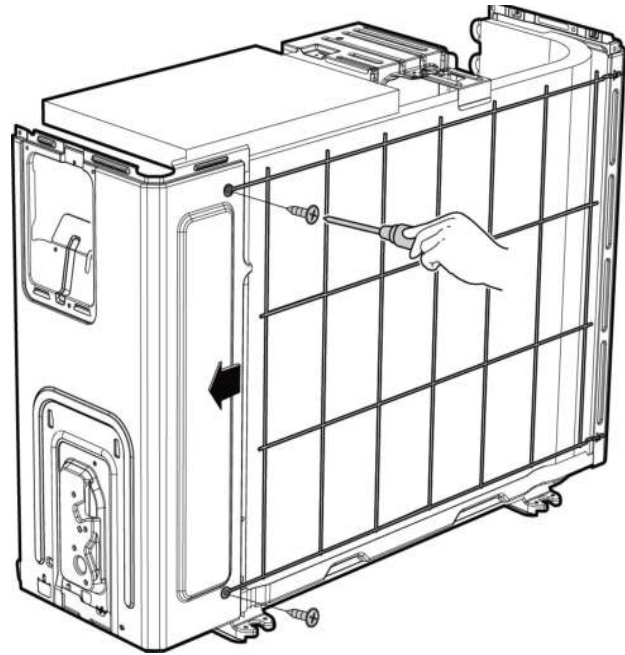

7) Remove the right panel screws (7) and then remove the right panel.

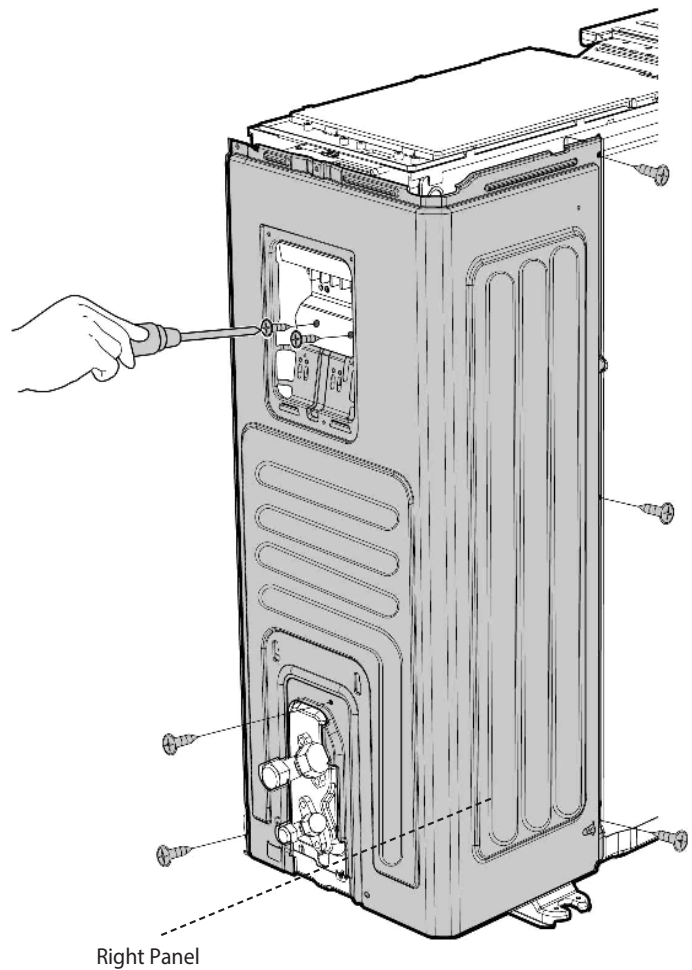

Procedure

- 1) Turn off the air conditioner and the power breaker.
- 2) Remove the big handle screws (2) and then remove the big handle.

Illustration

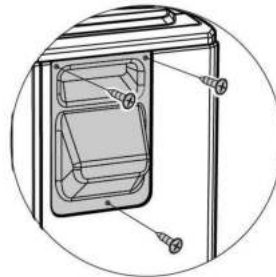
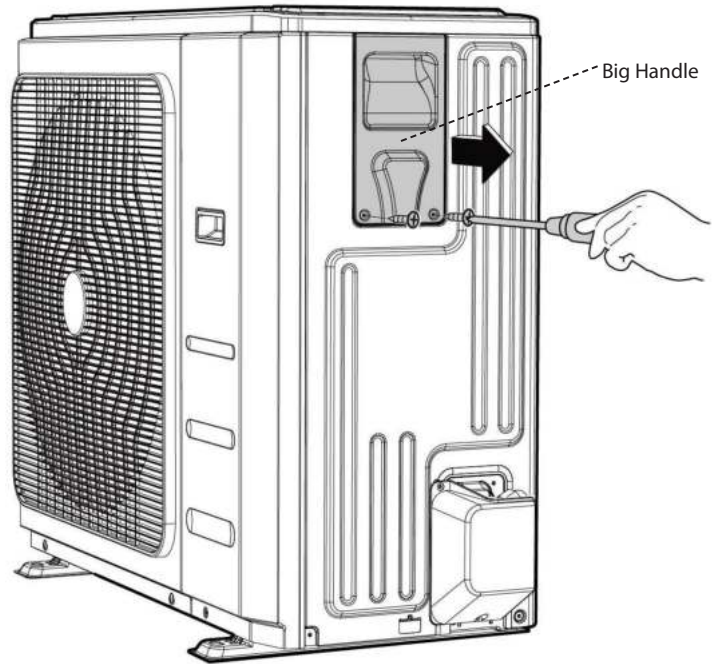

- 3) Remove the top cover screws (4) and then remove the top cover. Two of the screws are located under the big handle.

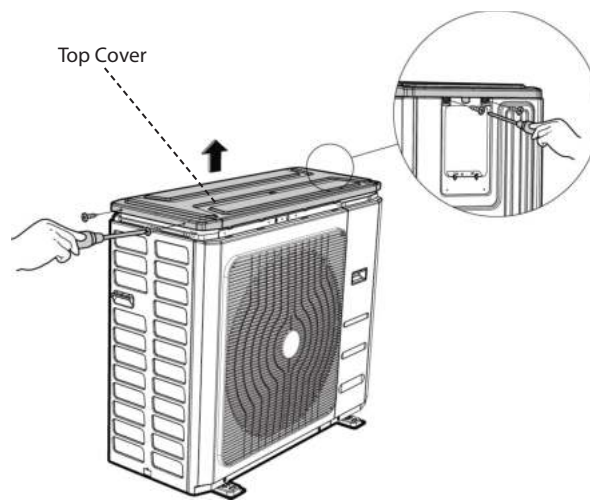

Procedure

Illustration

- 4) Remove the front right panel screws and then remove the front right panel (2 screws) .

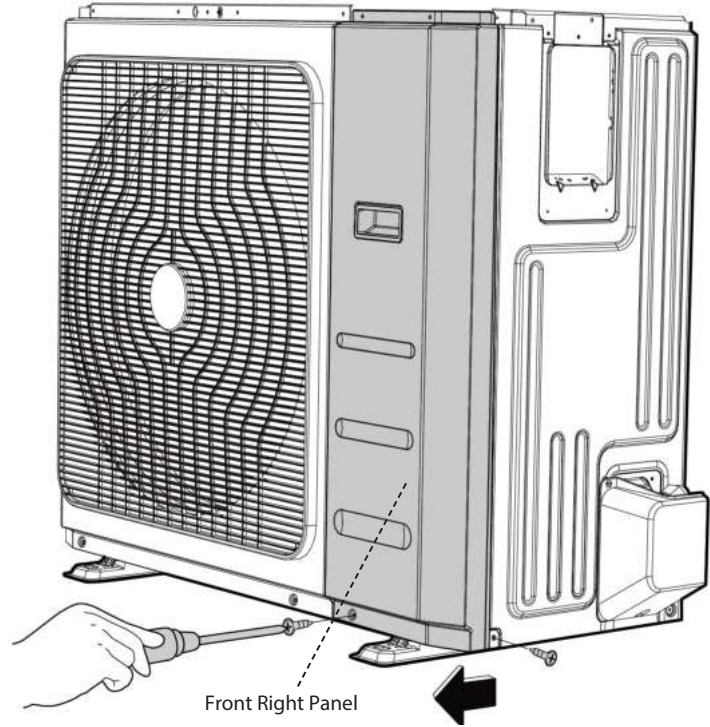

- 5) Remove the front panel screws (9) and then remove the front panel.

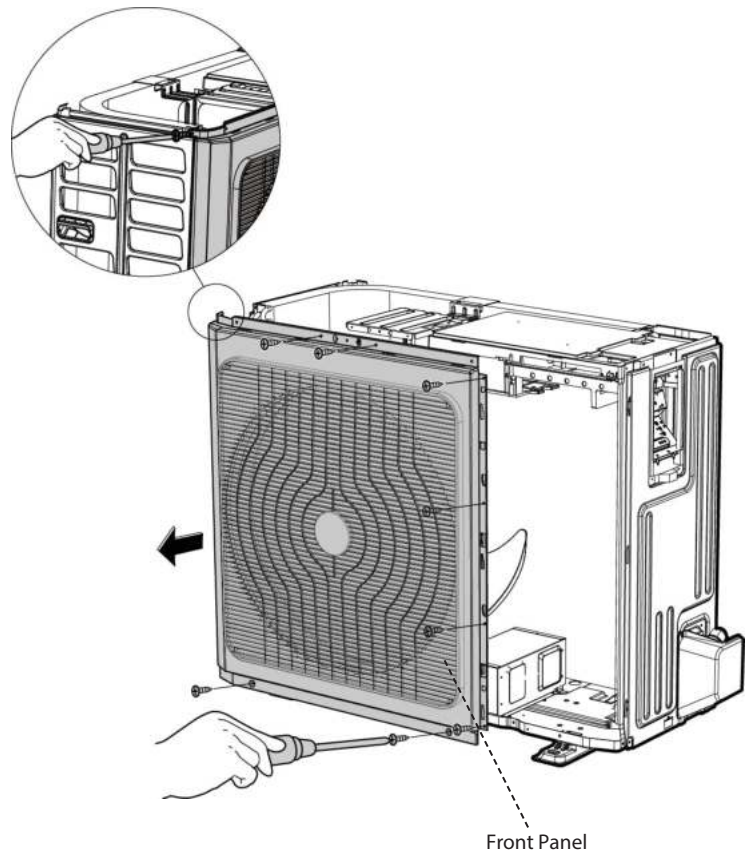

Procedure

Illustration

- 6) Remove the water collecting cover screws (2) and then remove the water collecting cover.

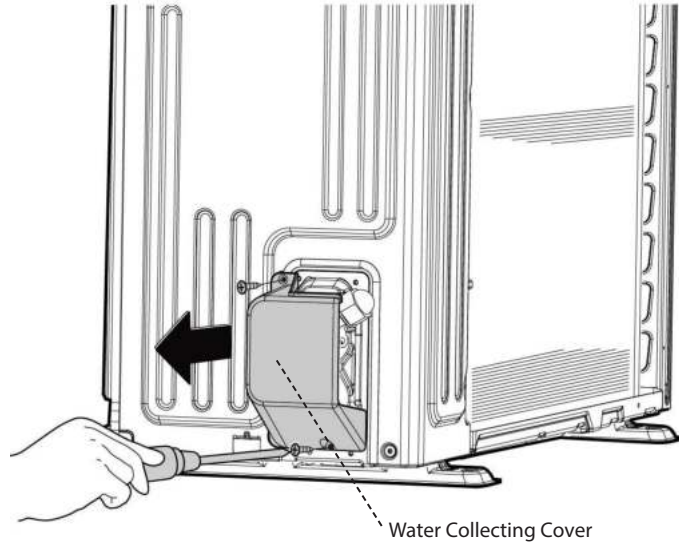

- 7) Remove the rear net screws (2) and then remove the rear net.

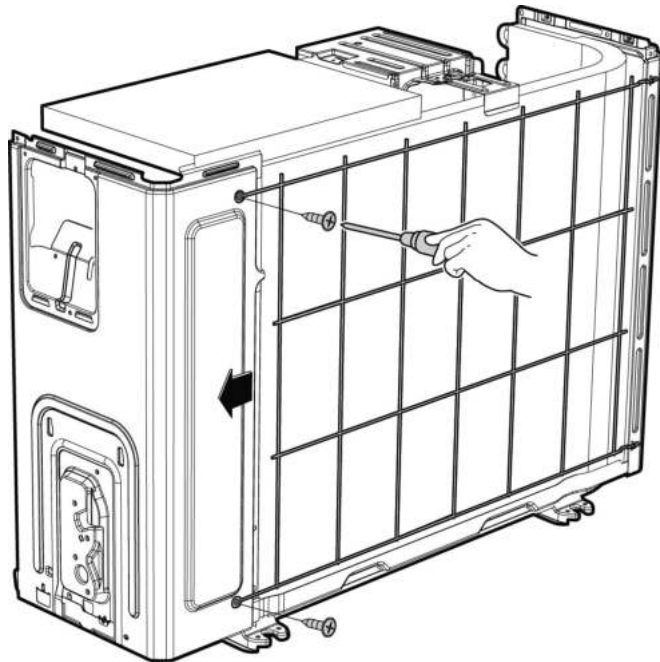

Procedure

Illustration

8) Remove the right panel screws (8) and then remove the right panel.

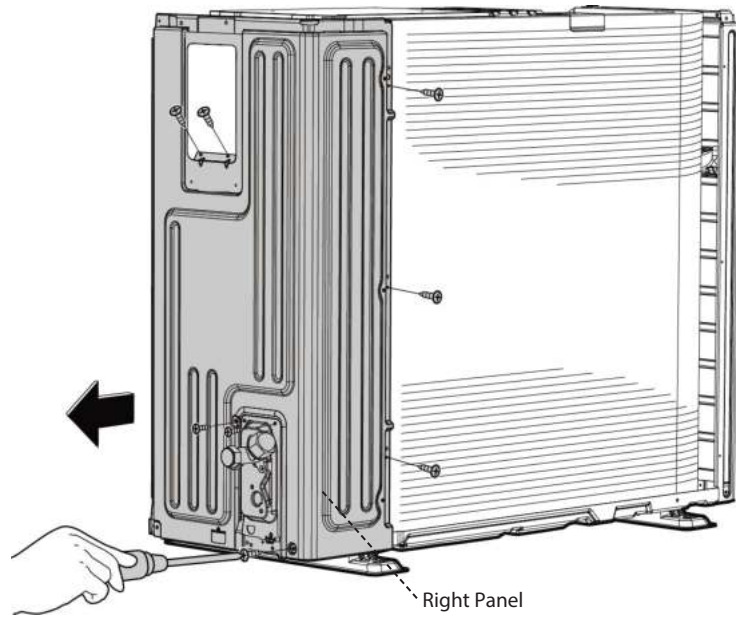

Procedure

- 1) Turn off the air conditioner and the power breaker.
- 2) Remove the big handle screw (1) and then remove the big handle.

Illustration

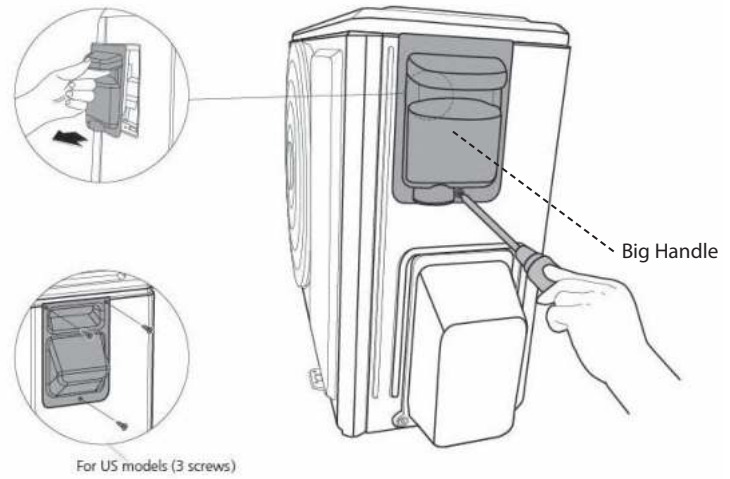

- 3) Remove the top cover screws (3) and then remove the top cover. One of the screws is located under the big handle.

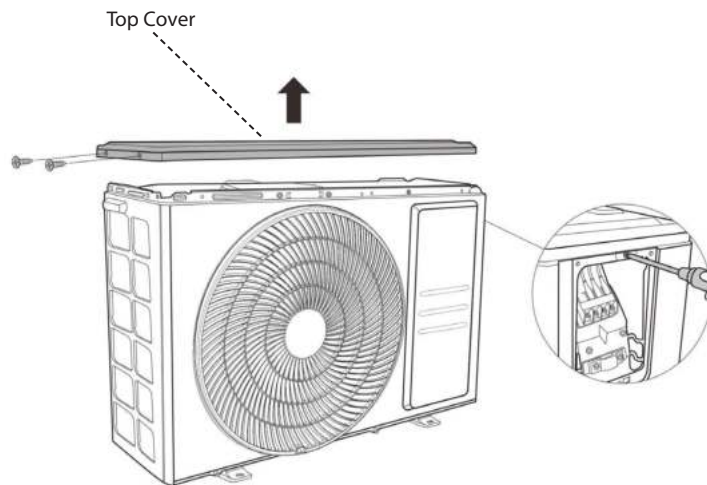

Procedure

Illustration

- 4) Remove the water collecting cover screws (2) and then remove the water collecting cover.

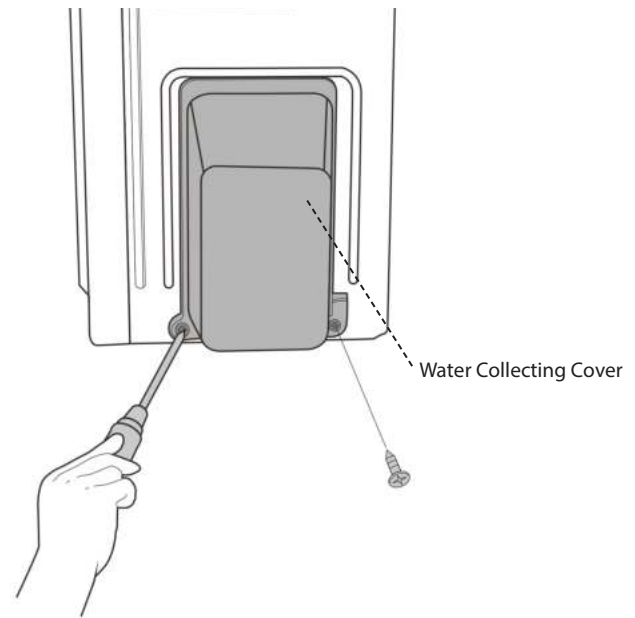

- 5) Remove the front panel screws (6 or 8) (inverter models) and then remove the front panel.

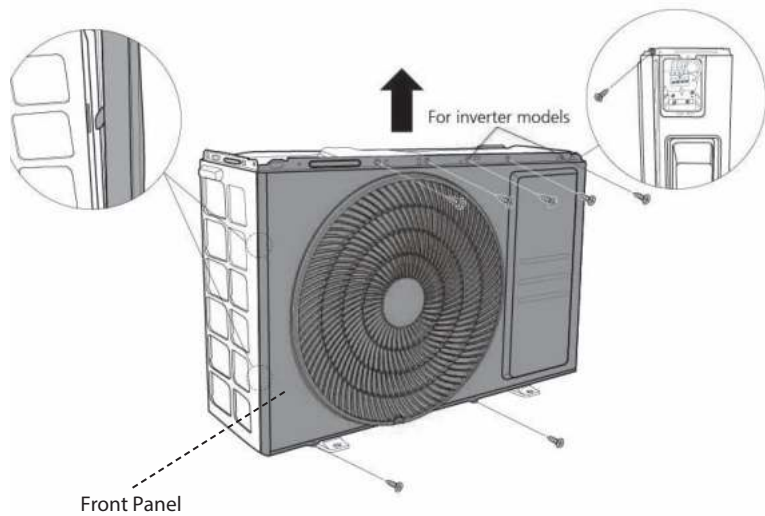

Procedure

Illustration

- 6) Remove the right panel screws (5) and then remove the right panel.

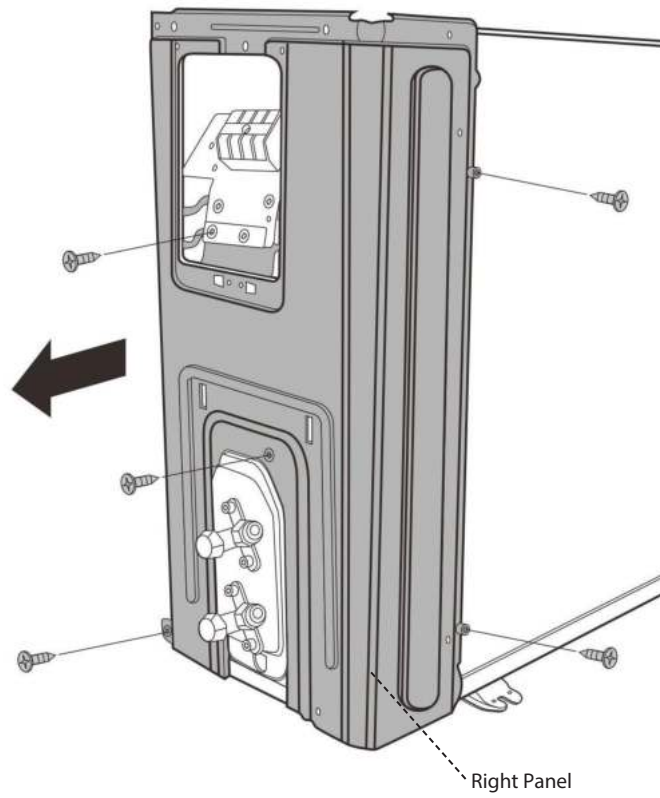

Procedure

- 1) Turn off the air conditioner and the power breaker.
- 2) Remove the big handle screw (1) and then remove the big handle.

Illustration

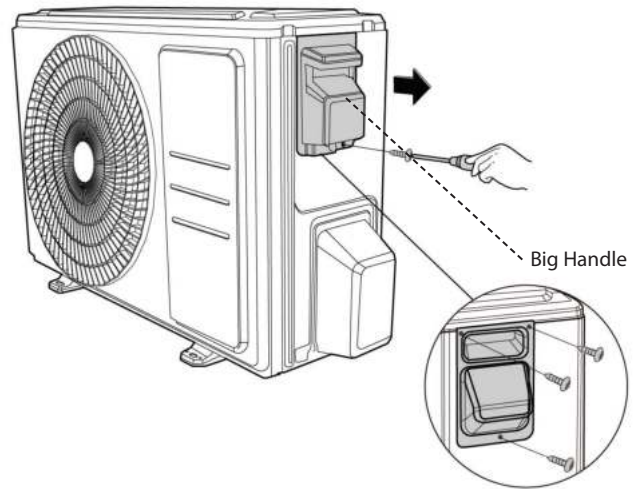

- 3) Remove the top cover screws (4) and then remove the top cover. One of the screws is located under the big handle.

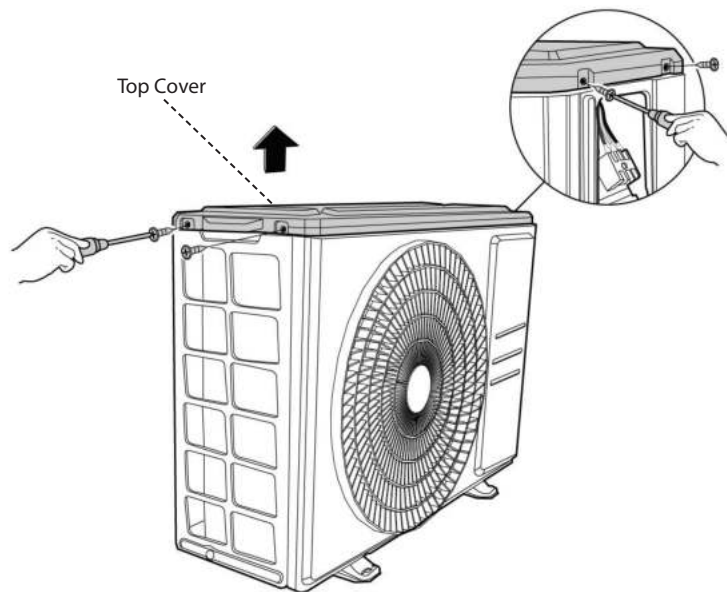

Procedure

Illustration

- 4) Remove the water collecting cover screws (2) and then remove the water collecting cover.

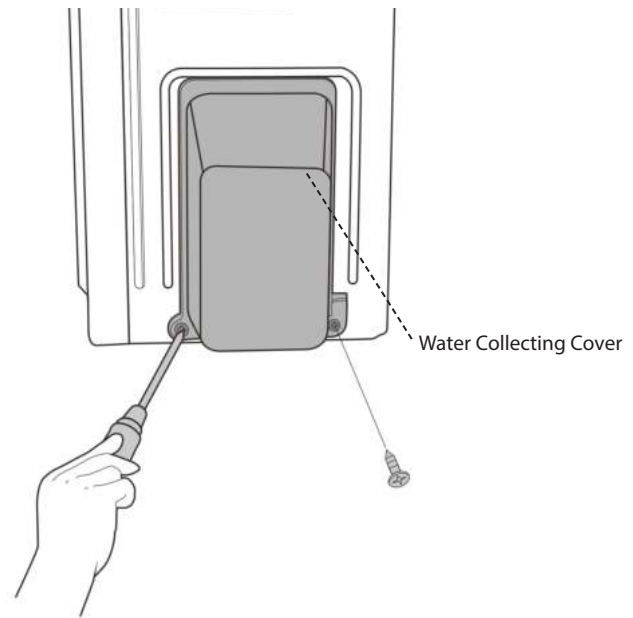

- 5) Remove the front panel screws (7 screws - on off models or 9 screws - inverter models) and then remove the front panel.

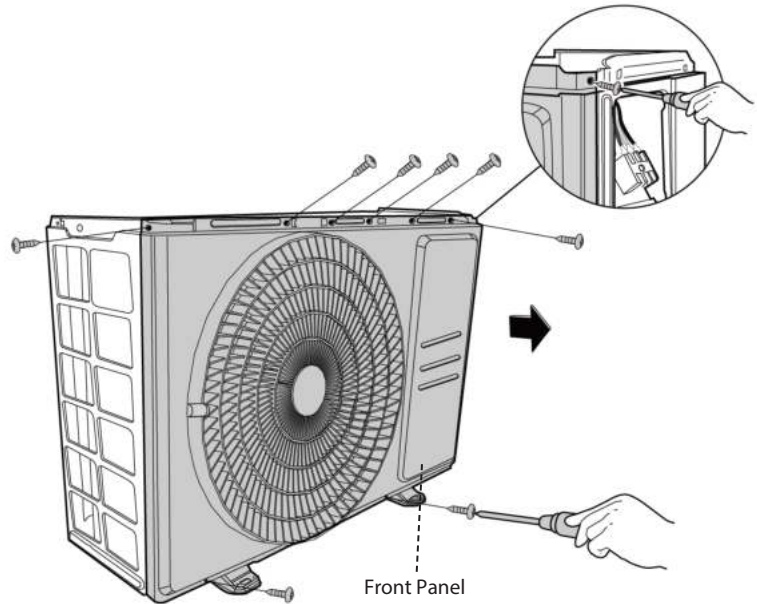

Procedure

Illustration

- 6) Remove the right panel screws (5) and then remove the right panel.

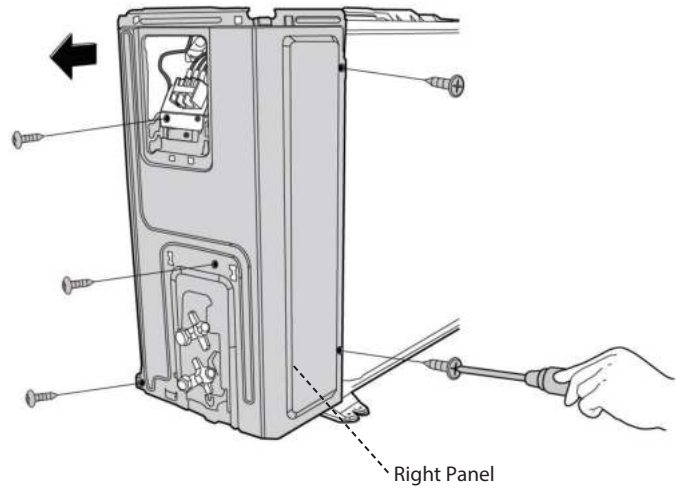

Procedure

- 1) Turn off the air conditioner and the power breaker.
- 2) Remove the big handle screw (1) and then remove the big handle.

Illustration

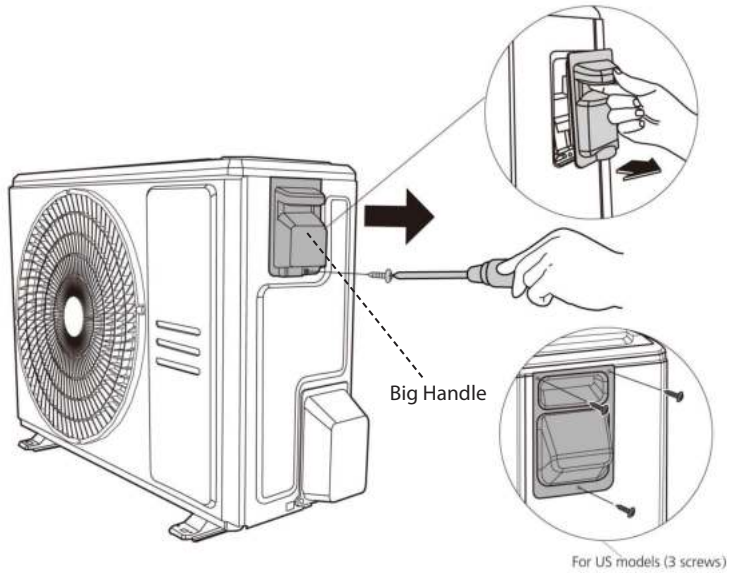

- 3) Remove the top cover screws (3) and then remove the top cover. One of the screws is located under the big handle.

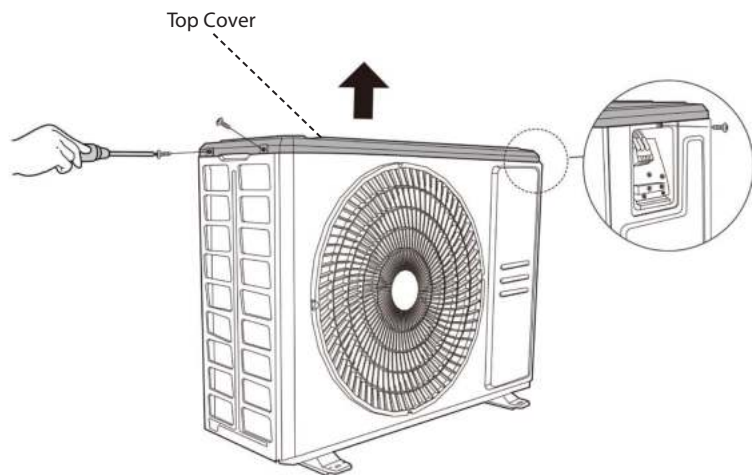

Procedure

Illustration

- 4) Remove the water collecting cover screws (2) and then remove the water collecting cover.

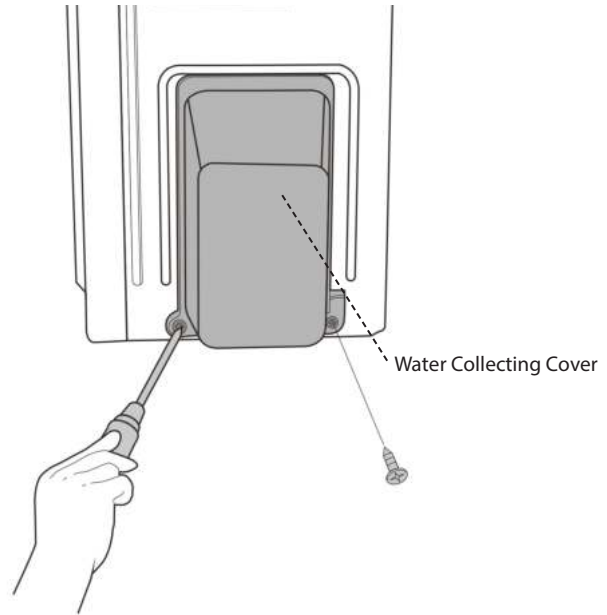

- 5) Remove the front panel screws (7 screws - onoff models or 9 screws - inverter models) and then remove the front panel.

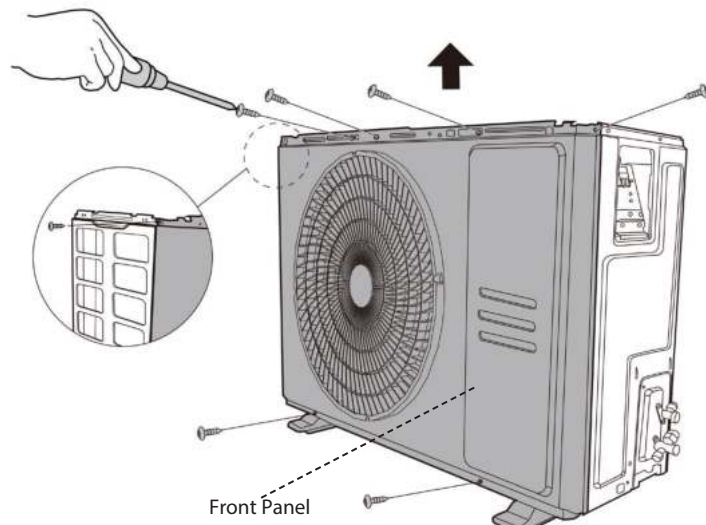

Procedure

Illustration

- 6) Remove the right panel screws (6) and then remove the right panel.

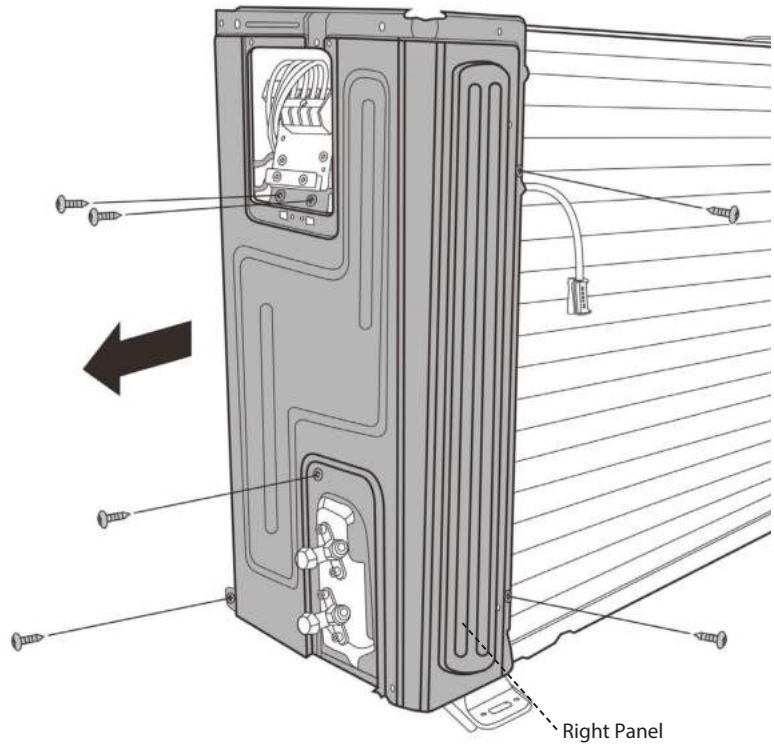

ELECTRICAL PARTS

Procedure	Illustration
<ol style="list-style-type: none">1) Remove the two screws secured to the electronic control board.2) Disconnect the fan motor connectors (blue wire, yellow wire, red wire, brown wire and black wire). The blue wire and red wire are on the capacitor. The black wire connects with terminal 4.3) Disconnect the wires connected to the compressor (black wire connects with terminal 1, blue and red wires connect with the compressor capacitor).4) Disconnect the wires connected to 4-way valve (blue wires on terminal 2 and 3).5) Remove the compressor capacitor securing screw then pull it out.6) Remove the electrical parts.7) For models with an AC conductor, remove the 2 screws.	<p>The illustration consists of two line drawings. The top drawing shows a hand using a screwdriver to remove two screws from the electronic control board. Labels include 'Two Screws', 'Compressor Wires', 'Connectors for fan motor', and 'Terminals 1 to 4'. The bottom drawing shows the removal of a compressor capacitor, with a label 'Compressor Wires' and an arrow indicating the removal of a screw.</p>

PCB Board 2

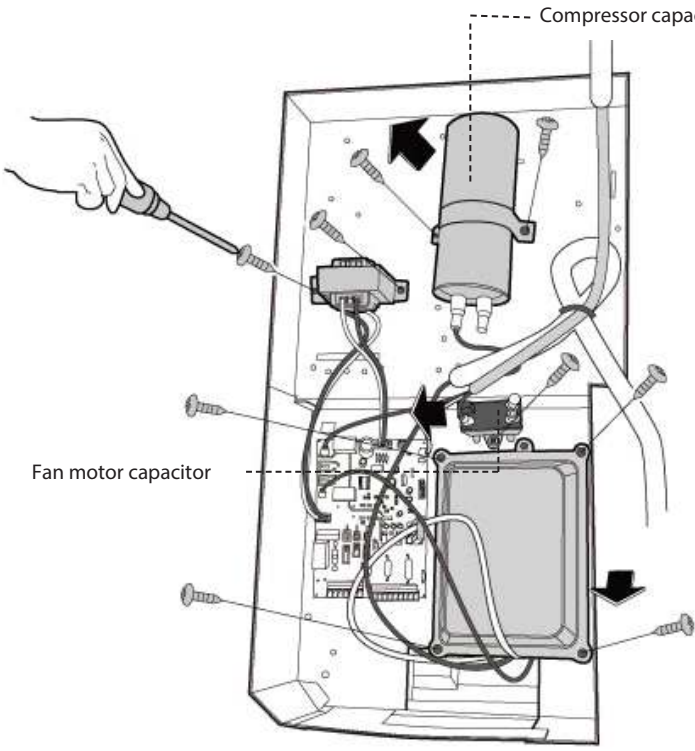
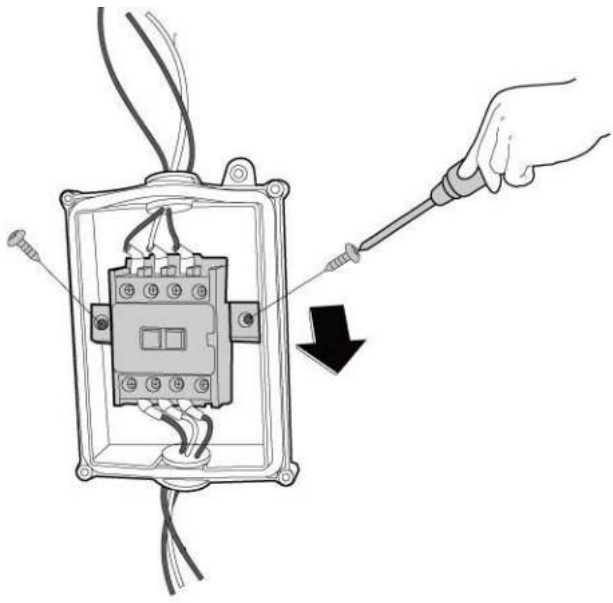
Procedure	Illustration
<ol style="list-style-type: none">1) Remove the compressor capacitor securing screw then pull it out.2) Remove the transformer's screws (2) and then remove it.3) Remove the fan motor capacitor screws , then remove it.4) Remove the electronic installing box screws (4) and then remove it.	 <p>The illustration shows a control panel with several components. A hand is using a screwdriver to remove a screw from the top of the panel. A dashed line points to a cylindrical component labeled 'Compressor capacitor'. Another dashed line points to a rectangular component labeled 'Fan motor capacitor'. Arrows indicate the removal of these components. The panel also shows a transformer and an electronic installing box.</p>
<ol style="list-style-type: none">5) Remove the AC contactor screws (2) and then remove it.	 <p>The illustration shows an AC contactor being removed from its housing. A hand is using a screwdriver to remove a screw from the top of the contactor. An arrow indicates the removal of the contactor. The contactor has several terminals and wires connected to it.</p>

Procedure	Illustration
<p>6) Disconnect the wires connected to the compressor (red wire connects with the PCB board, others connect with the terminals) (for some models).</p> <p>7) Disconnect the fan motor connectors (blue wire, red wire, brown wire and black wire. The blue wire and brown wire are on the capacitor. The black wire connects with a terminal and the red wire is on the board (for some models).</p> <p>8) Disconnect the wires connected to the 4-way valve (for some models).</p> <p>9) Disconnect the wires connected to the transformer (for some models).</p> <p>10) Disconnect the other wires connected to terminals (for some models).</p> <p>11) Remove the PCB board.</p>	

PCB Board 3

Procedure	Illustration
<p>1) Disconnect the connectors for the fan motor.</p> <p>2) Disconnect the wires connected to the compressor.</p> <p>3) Disconnect the wires connected to the pipe temperature sensor.</p> <p>4) Disconnect the ground wire.</p> <p>5) Remove the PCB board.</p>	

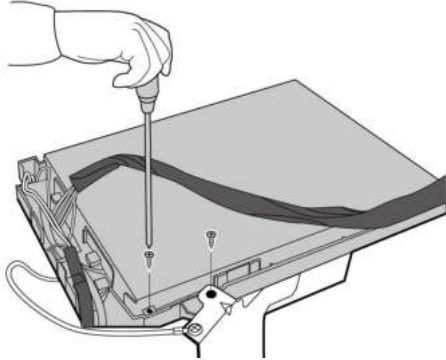
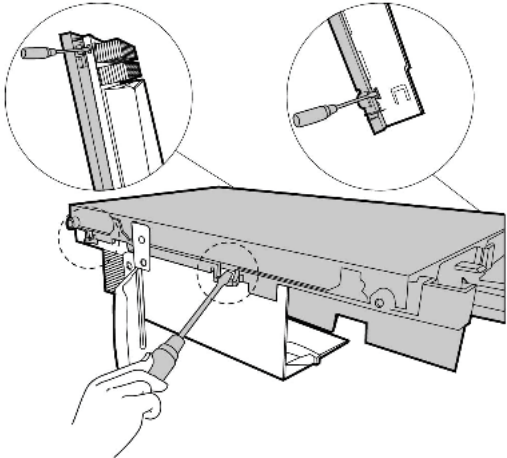
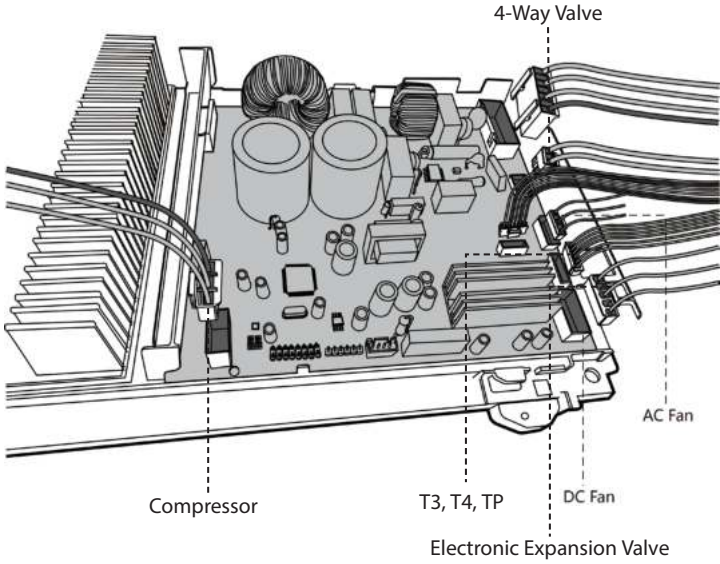
Procedure	Illustration
<p>1) Remove the top cover screws (2).</p>	
<p>2) Loosen the hooks (4) and open the electronic control box cover.</p>	
<p>3) Disconnect the fan motor connector from the electronic control board.</p>	
<p>4) Remove the compressor connector.</p>	
<p>5) Pull out the two blue wires connected to the 4-way valve.</p>	
<p>6) Pull out condenser connectors coil temp. sensor(T3), outdoor ambient temp. sensor(T4) and the discharge temp. sensor.</p>	
<p>7) Disconnect the electronic expansion valve wire.</p>	
<p>8) Remove the electronic control board.</p>	

PCB Board 5

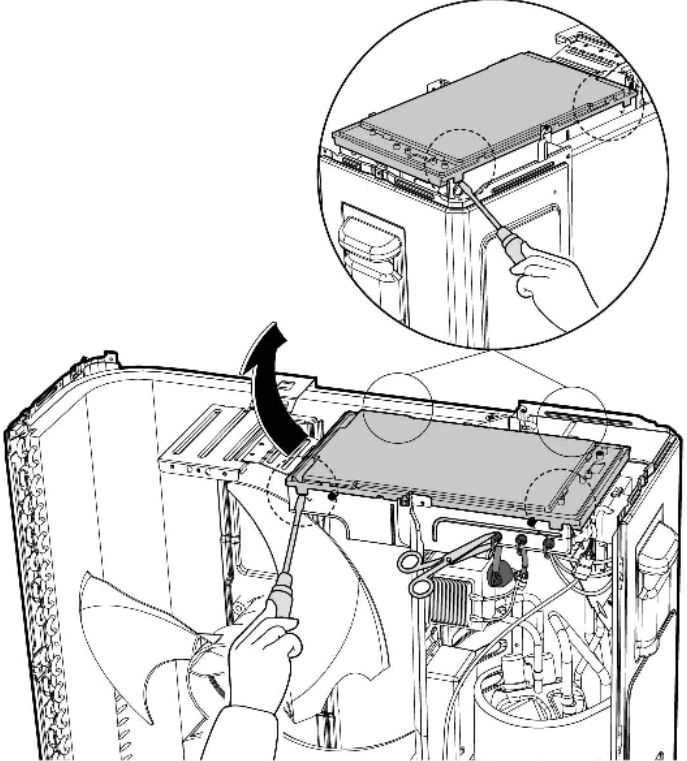
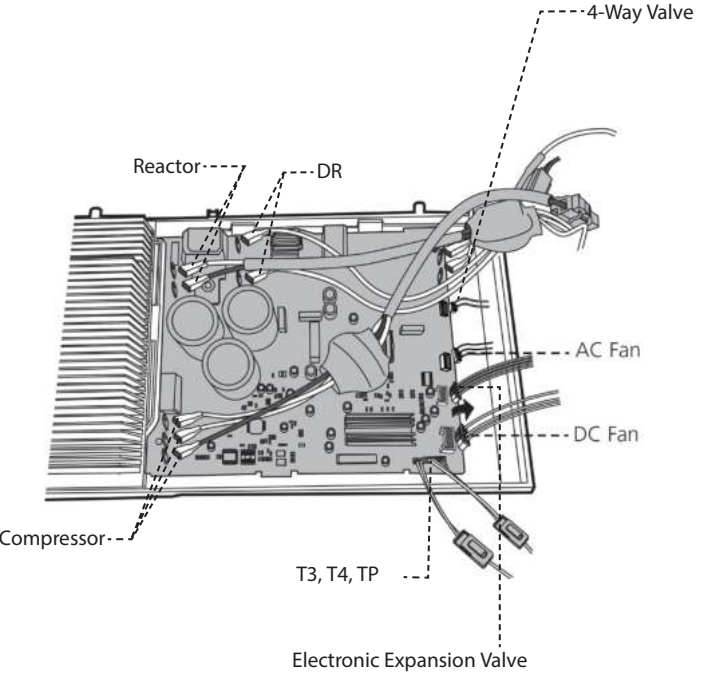
Procedure	Illustration
<p>1) Loosen the hooks (4) then open the electronic control box cover.</p>	
<p>2) Disconnect the fan motor connector from the electronic control board.</p> <p>3) Remove the compressor connector.</p> <p>4) Pull out the two blue wires connected to the 4-way valve.</p> <p>5) Pull out the condenser connectors coil temp. sensor(T3), outdoor ambient temp. sensor(T4) and discharge temp. sensor(TP).</p> <p>6) Disconnect the electronic expansion valve wire.</p> <p>7) Remove the electronic control board.</p>	

PCB Board 6

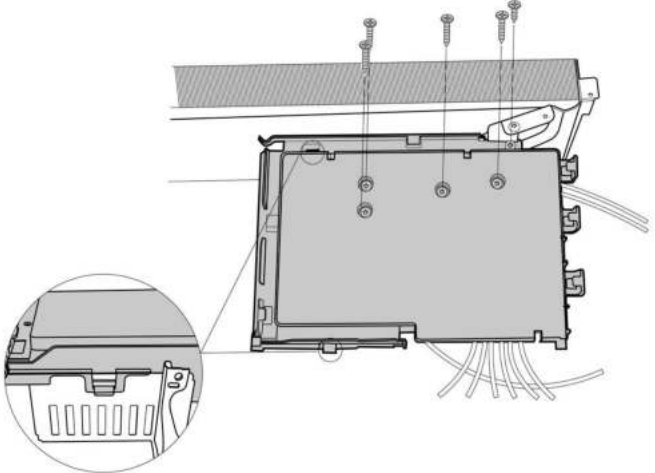
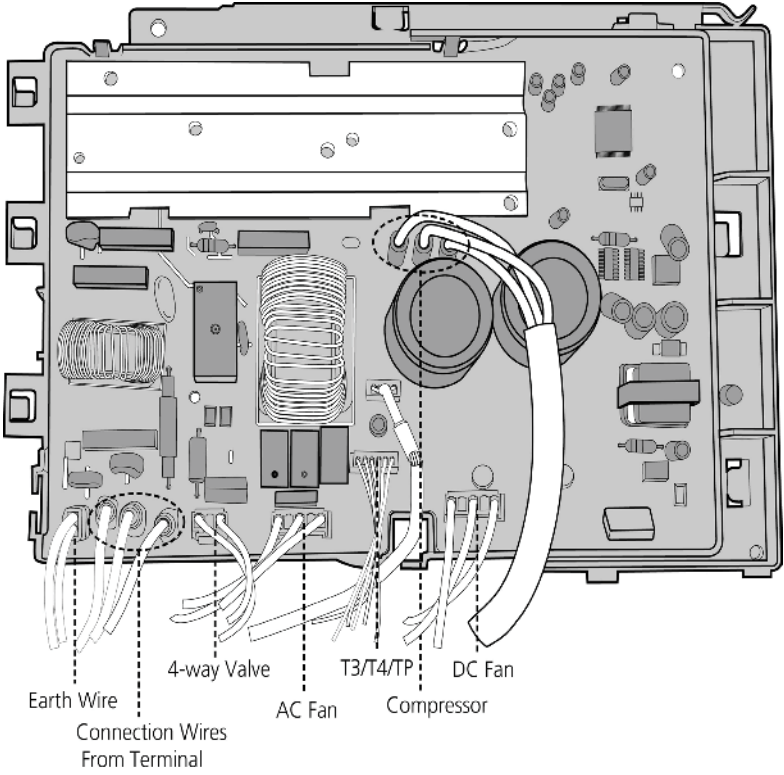
Procedure	Illustration
<p>1) Remove the screws (5) and loosen the hooks (2), then open the electronic control box cover.</p>	
<p>2) Disconnect the fan motor connector from the electronic control board.</p> <p>3) Remove the compressor connector.</p> <p>4) Pull out the two blue wires connected to the four way valve.</p> <p>5) Pull out condenser connectors coil temp. sensor(T3), outdoor ambient temp. sensor(T4) and discharge temp. sensor(TP).</p> <p>6) Disconnect the electronic expansion valve wire.</p> <p>7) Remove the DR connector and reactor.</p> <p>8) Remove the electronic control board.</p>	

PCB Board 7

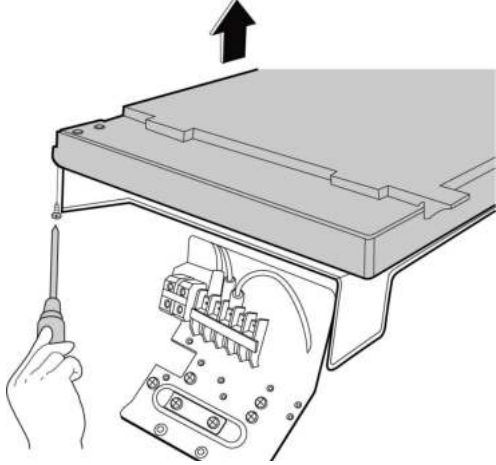
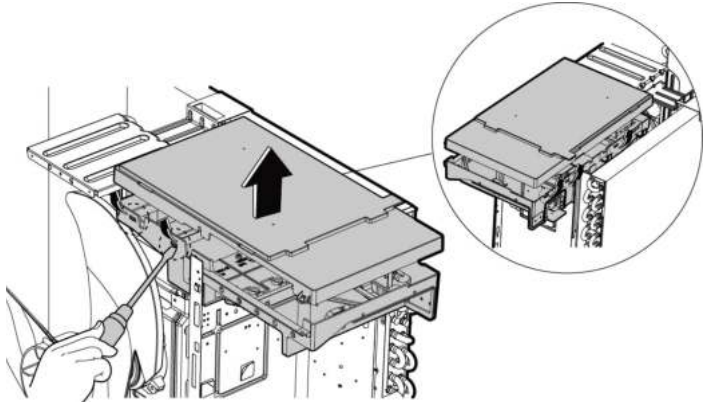
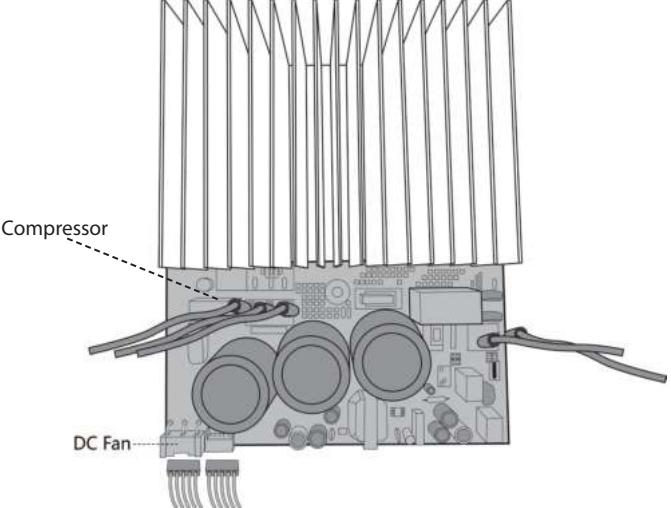
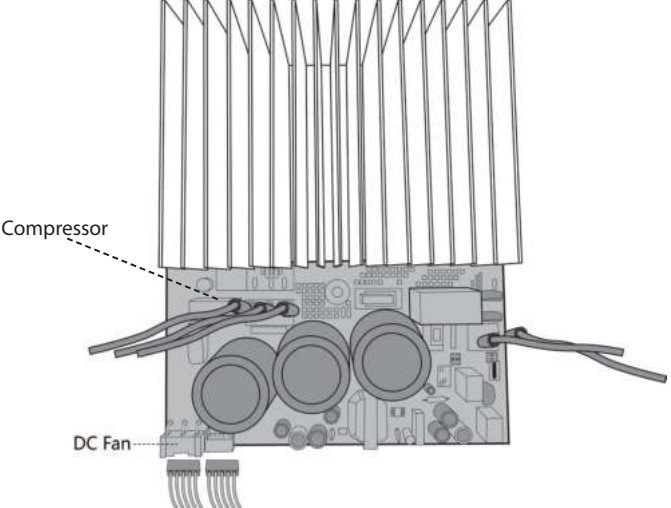
Procedure	Illustration
<p>1) Remove the top cover screw (1).</p>	 A hand is shown using a screwdriver to remove a screw from the top cover of the PCB board. An upward-pointing arrow indicates the direction to lift the cover.
<p>2) Loosen the hooks (5 hooks) then open the electronic control box cover.</p>	 A hand is shown using a screwdriver to loosen hooks on the electronic control box cover. An upward-pointing arrow indicates the direction to lift the cover. A circular inset shows a close-up of the hooks being loosened.
<p>3) Disconnect the fan motor connector from the IPM board.</p>	 A hand is shown disconnecting the fan motor connector from the IPM board. The fan motor is labeled 'DC Fan'.
<p>4) Remove the compressor connector.</p>	 A hand is shown removing the compressor connector from the IPM board. The compressor is labeled 'Compressor'.

Procedure	Illustration
<ol style="list-style-type: none"> 5) Pull out the wire connected to the terminal. 6) Remove the condenser connectors coil temp. sensor(T3),outdoor ambient temp. sensor(T4) and discharge temp. sensor(TP). 7) Disconnect the electronic expansion valve wire. 8) Remove the connector for the 4-way valve. 9) Remove the connector for the reactor. 10) Remove the electronic control box. 	

PCB Board 8

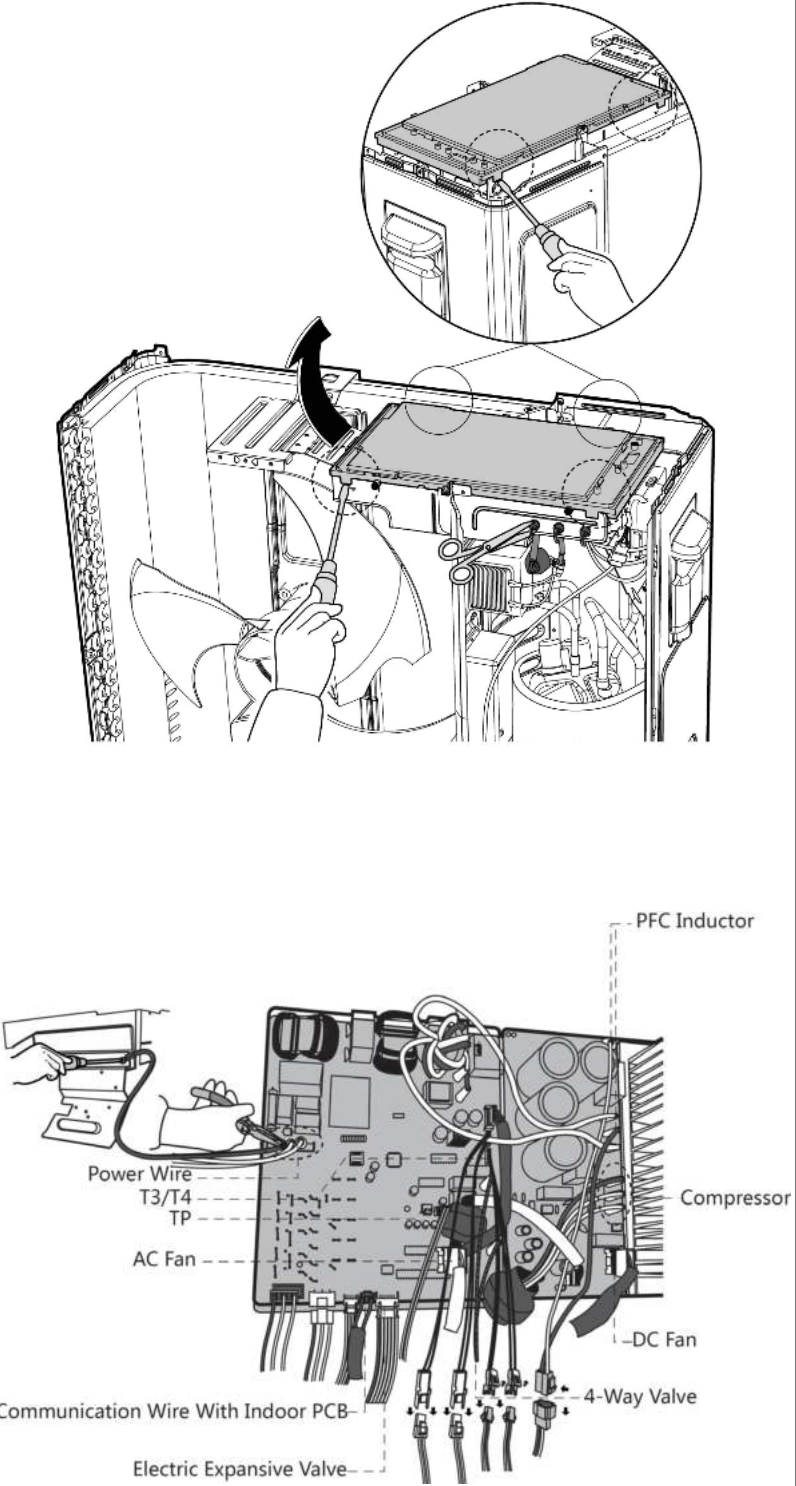
Procedure	Illustration
<ol style="list-style-type: none"> 1) Loosen the hooks (4) then open the electronic control box cover. 2) Disconnect the outdoor DC fan connector from the electronic control board. 3) Remove the compressor connector. 4) Pull out the two blue wires connected to the 4-way valve. 5) Remove the condenser connectors coil temp. sensor(T3), outdoor ambient temp. sensor(T4) and discharge temp. sensor(TP). 6) Disconnect the electronic expansion valve wire. 7) Disconnect the communication wire indoor PCB. 8) Disconnect the PFC inductor. 9) Remove the electronic control box. 	 <p>The illustration is divided into two parts. The upper part shows a hand using a screwdriver to lift the electronic control board cover, with a circular inset providing a magnified view of the cover being detached. The lower part shows the control board with various components labeled for disconnection: Power Wire, T3/T4, TP, AC Fan, PFC Inductor, Compressor, DC Fan, 4-Way Valve, Communication Wire With Indoor PCB, and Electric Expansive Valve. A hand is shown disconnecting the power wire from the board.</p>

PCB Board 9

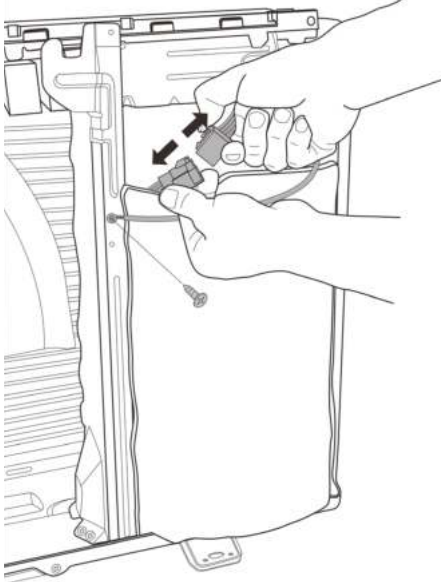
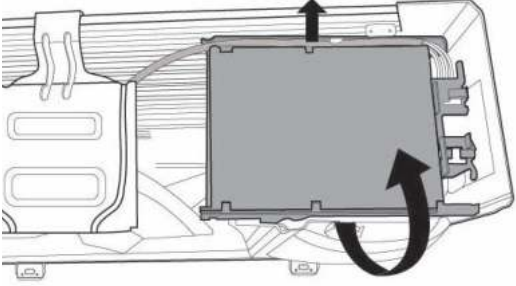
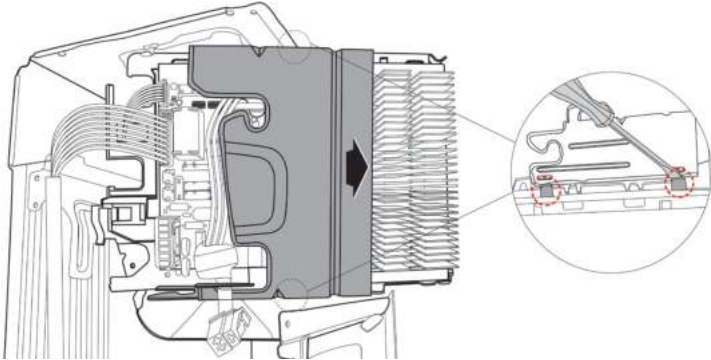
Procedure	Illustration
<p>1) Disconnect the compressor connector and release the ground wire (1 screw).</p>	 <p>The illustration shows a hand using a screwdriver to remove a screw from a ground wire terminal. Another hand is shown pulling a connector away from a terminal. Arrows indicate the direction of movement for both actions.</p>
<p>2) Pull out the wires from the electrical supporting plate and turn over the electronic control assembly.</p>	 <p>The illustration shows a top-down view of the electronic control assembly. A hand is shown pulling wires from a supporting plate. A curved arrow indicates the assembly being turned over.</p>
<p>3) Remove the electronic installing box subassembly (4 hooks).</p>	 <p>The illustration shows the electronic installing box subassembly being removed from the main unit. A circular inset provides a magnified view of the four hooks used for installation, with red circles highlighting the hook locations.</p>

Procedure

Illustration

4) Remove the fixing board (2 hooks).

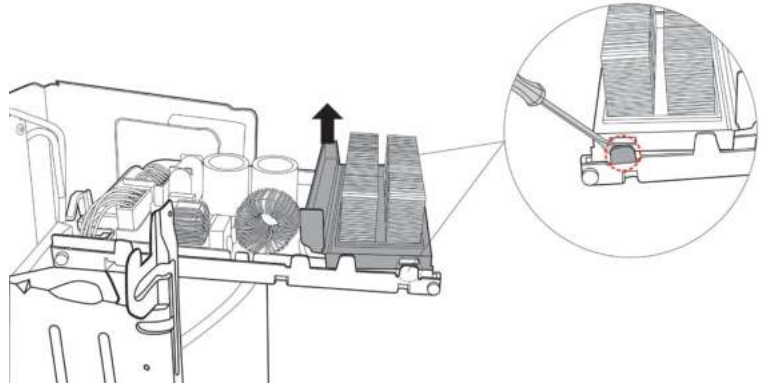

5) Disconnect the connectors from the electronic control board.

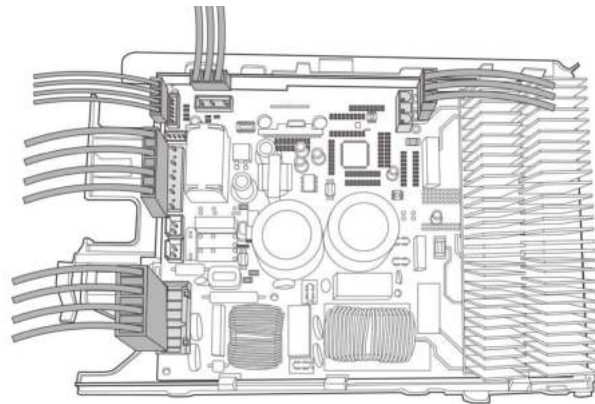

6) Remove the electronic control board (4 hooks).

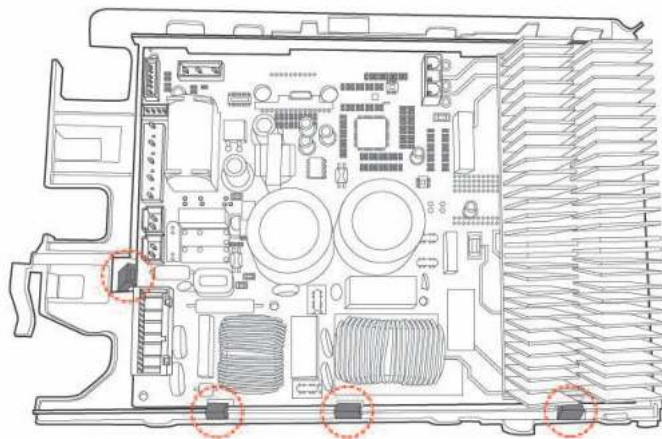

PCB Board 10

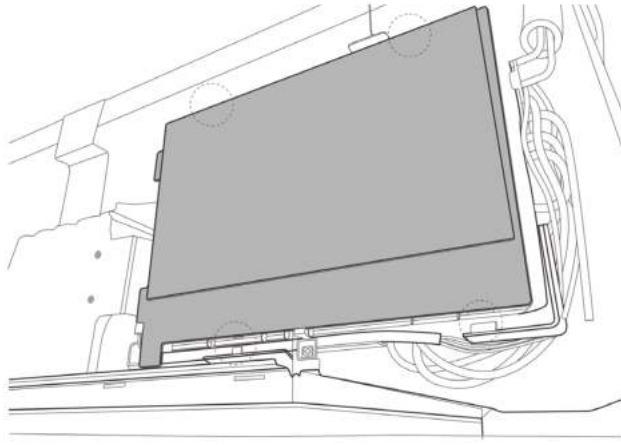
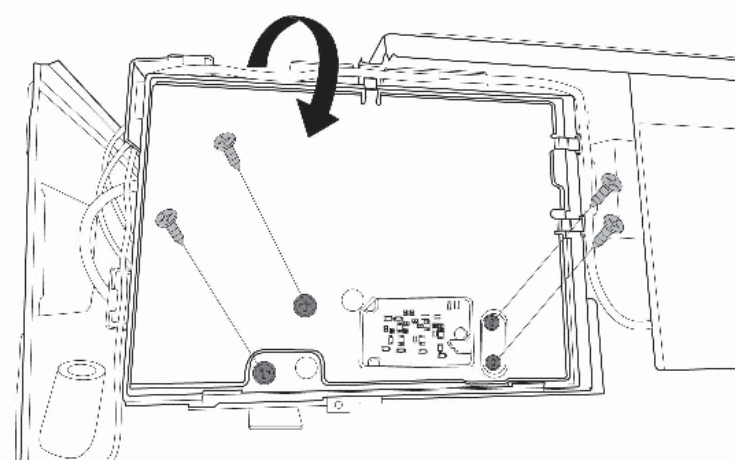
Procedure	Illustration
<p>1) Loosen the hooks (4) then open the electronic control box cover.</p>	 A line drawing showing the electronic control box cover being detached from the main unit. The cover is shown in a slightly open position, with four hooks (indicated by dashed circles) being loosened. Wires are visible on the right side of the unit.
<p>2) Remove the screws (4) on the electronic control board then turn over the electronic control board.</p>	 A line drawing showing the electronic control board being turned over. The board is shown in a horizontal position, with four screws (indicated by dashed circles) being removed. A curved arrow indicates the direction of rotation. The board is mounted on a metal frame, and various components and wires are visible.

Procedure

Illustration

- 3) Pull out the connectors.
- 4) Remove the screws (9), loosen the hooks (3) then remove the electronic control board.

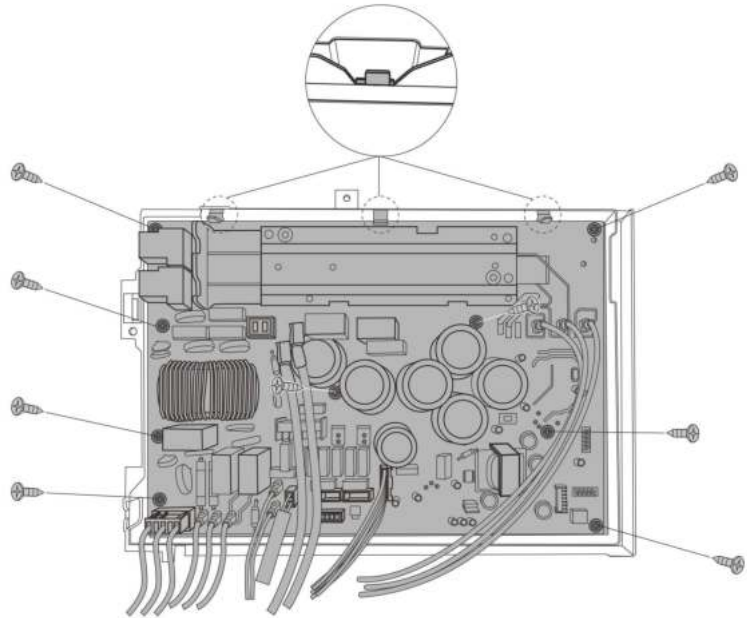

- 5) Remove the screws (2) then remove the electronic control box subassembly on the partition board assembly.

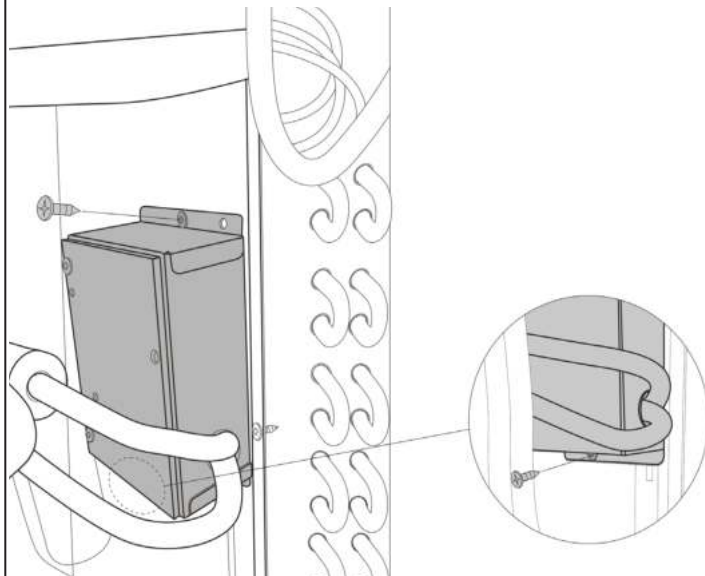

Procedure

- 6) Remove the screws (2) and the two connectors then remove the inverter control board.

Illustration

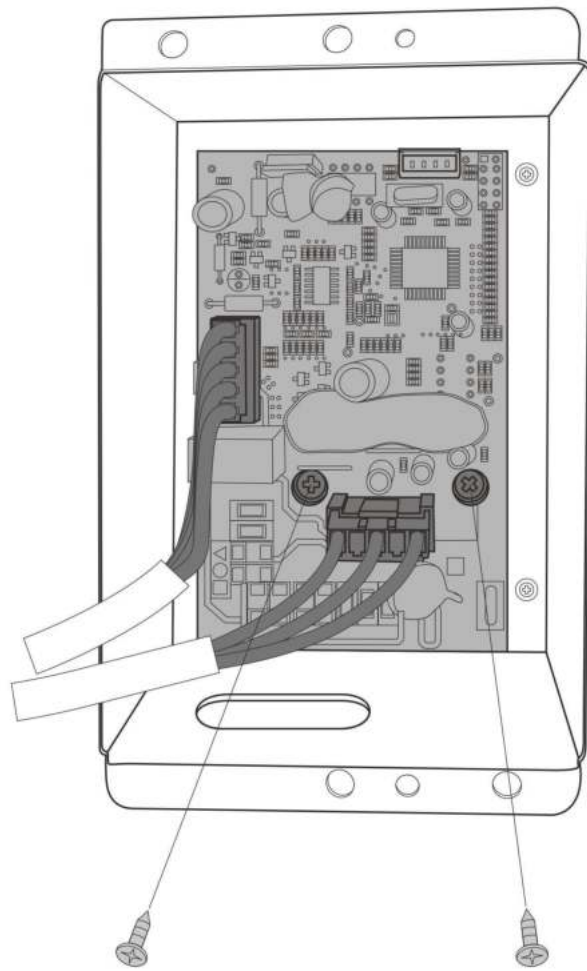

PCB Board 11

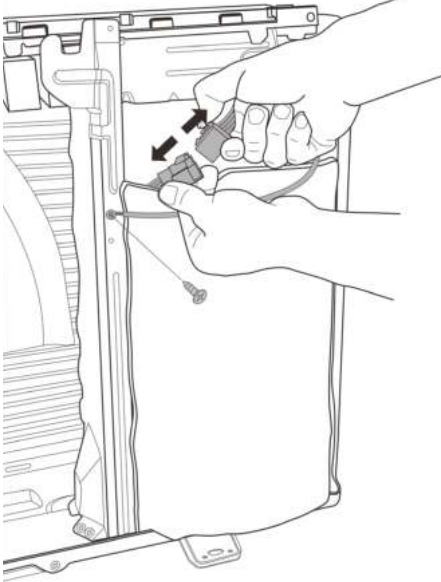
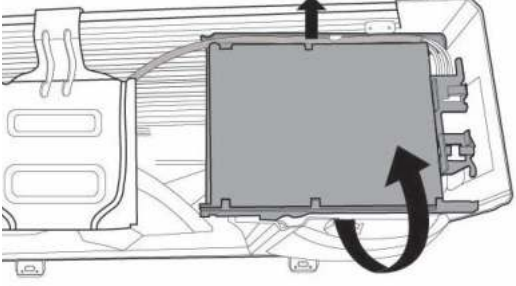
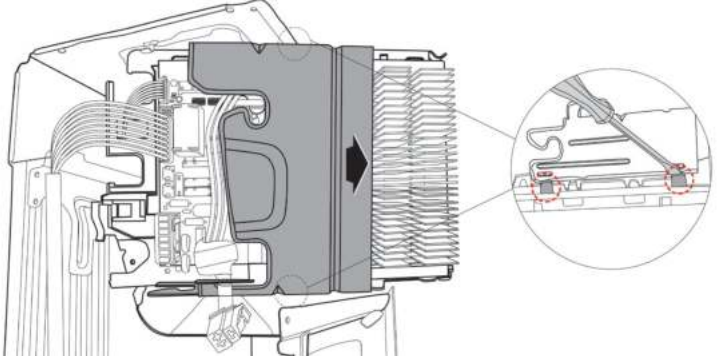
Procedure	Illustration
<p>1) Disconnect the compressor connector and release the ground wire (1 screw).</p>	
<p>2) Remove the wires from the electrical supporting plate and turn over the electronic control assembly.</p>	
<p>3) Remove the electronic installing box subassembly (4 hooks).</p>	

Procedure

Illustration

4) Remove the fixing board (2 hooks).

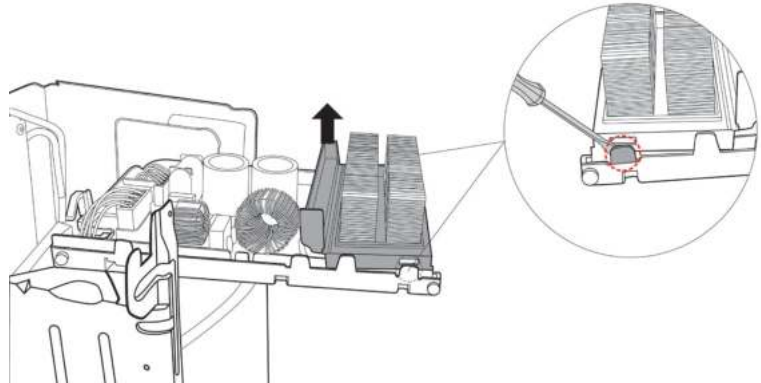

5) Disconnect the connectors from the electronic control board.

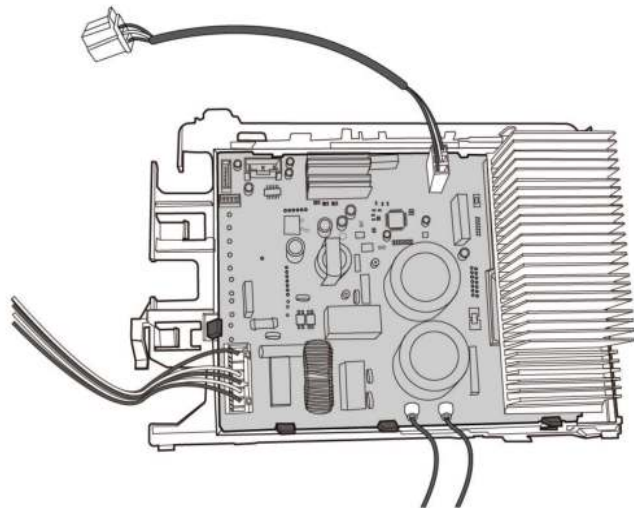

6) Remove the electronic control board (4 hooks).

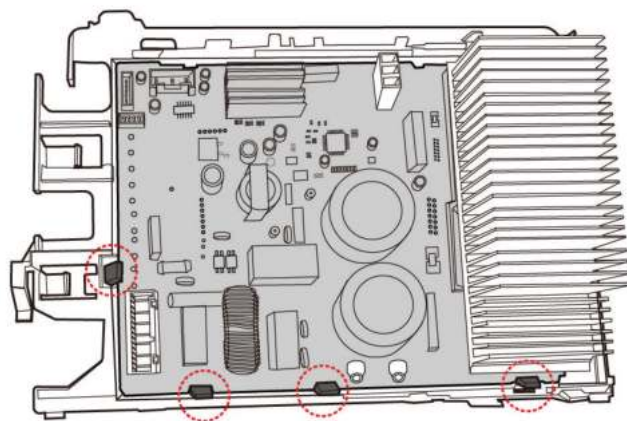

PCB Board 12

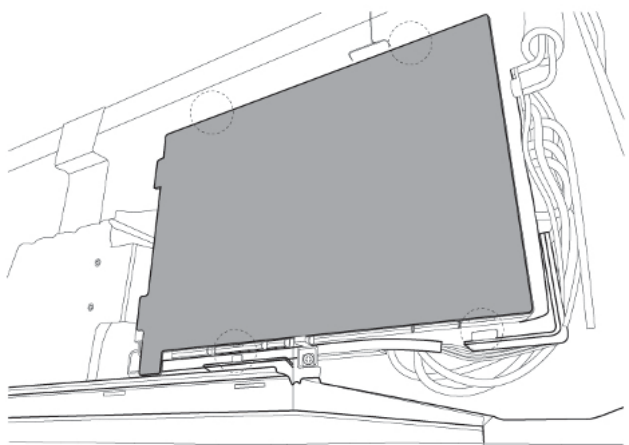
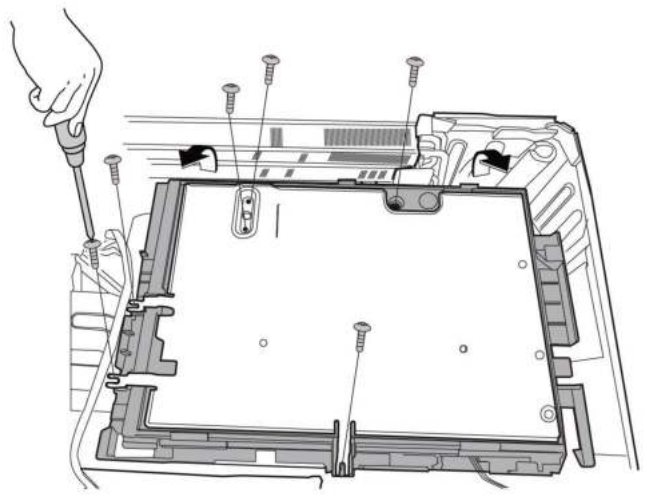
Procedure	Illustration
<p>1) Loosen the hooks (4), then open the electronic control box cover.</p>	 A line drawing showing the electronic control box cover being lifted away from the main unit. The cover is a dark grey rectangular panel. Four dashed circles indicate the locations of hooks (4) that are being loosened. The main unit is shown in profile, and the cover is being moved upwards and to the right.
<p>2) Remove the screws (6) on the electronic control board, then turn over the electronic control board.</p>	 A line drawing showing the electronic control board being removed from the main unit. A hand is using a screwdriver to remove screws (6) from the board. The board is shown being turned over, revealing its underside. The main unit is shown in profile, and the board is being moved downwards and to the left.

Procedure

Illustration

- 3) Pull out the connectors.
- 4) Remove the screws (4) then remove the electronic control board.

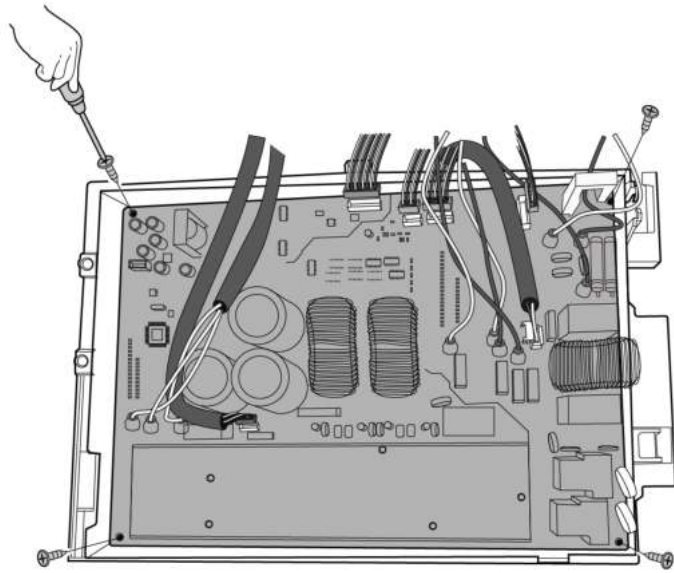

Fan Assembly

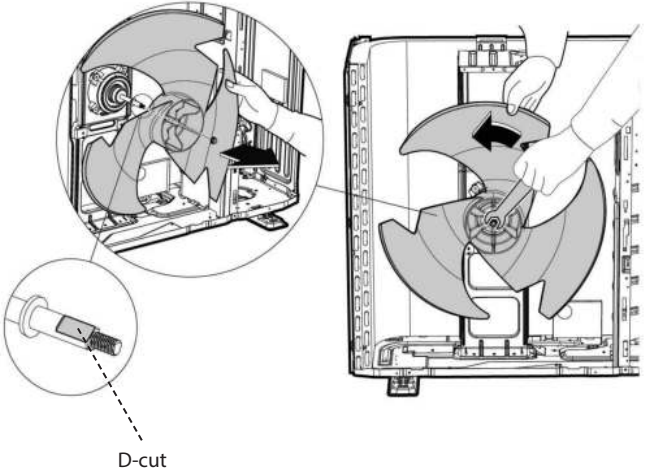
Procedure	Illustration
<ol style="list-style-type: none">1) Remove the nut securing the fan with a spanner.2) Remove the fan.	 <p>The illustration shows a person using a spanner to remove a nut from the fan assembly. A circular inset provides a magnified view of the fan blades and the nut. A label 'D-cut' points to a specific part of the fan assembly.</p>

Fan Motor

NOTE: Remove the panel plate and the connection of fan motor on PCB before disassembling fan motor.

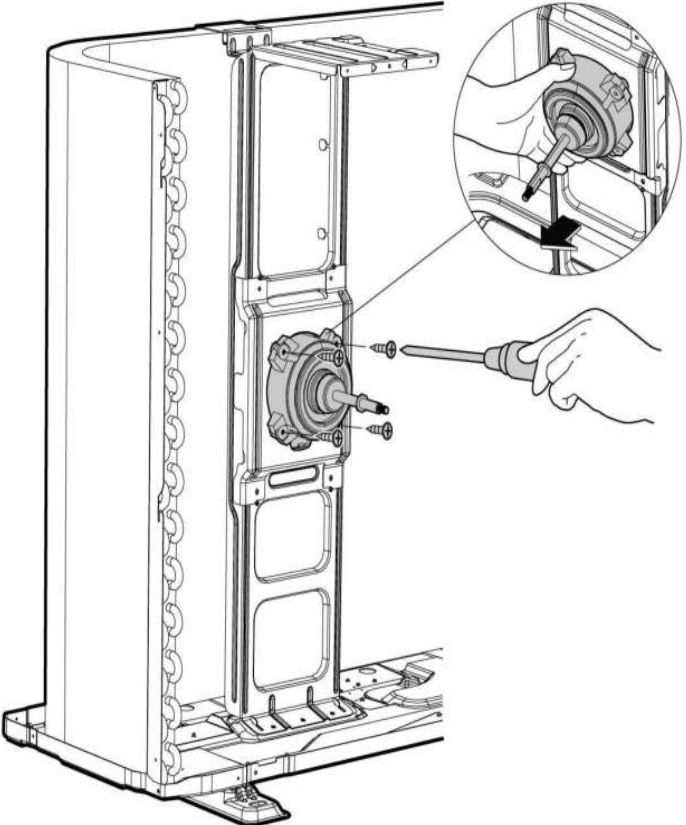
Procedure	Illustration
<ol style="list-style-type: none">3) Remove the fan motor screws (4).4) Remove the fan motor.	 <p>The illustration shows a person using a screwdriver to remove screws from the fan motor. A circular inset provides a magnified view of the fan motor and the screws.</p>

Sound Blanket

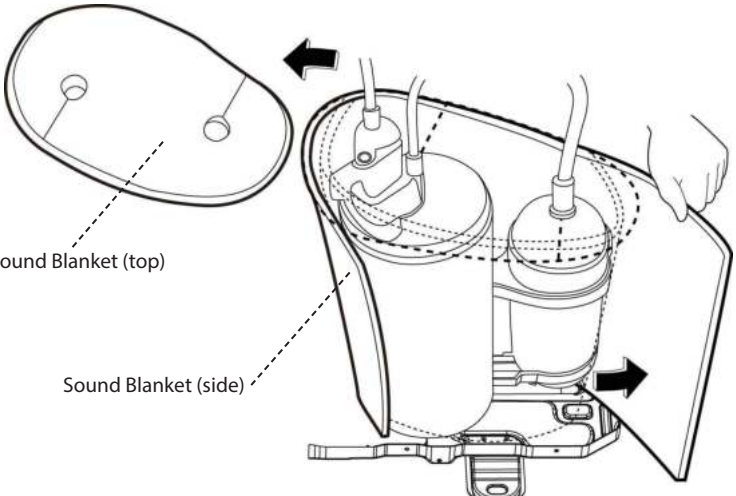
Procedure	Illustration
1) Remove the sound blanket (side and top).	 <p>The illustration shows a medical device with two cylindrical components. A hand is shown peeling back a sound blanket from the side of the device. A separate view of the top of the blanket is shown to the left, with two circular openings. Dotted lines indicate the original position of the blanket. Arrows indicate the direction of removal: one arrow points left from the top of the blanket, and another points right from the side of the blanket.</p> <p>Sound Blanket (top)</p> <p>Sound Blanket (side)</p>

Four Way Valve (for heat pump models)



WARNING

Evacuate the system and confirm that there is no refrigerant left in the system before removing the four-way valve and the compressor. (For R32 & R290, evacuate the system with the vacuum pump; flush the system with nitrogen; then repeat the two steps before heating up the brazed parts. This operation should be implemented by an authorized technician.

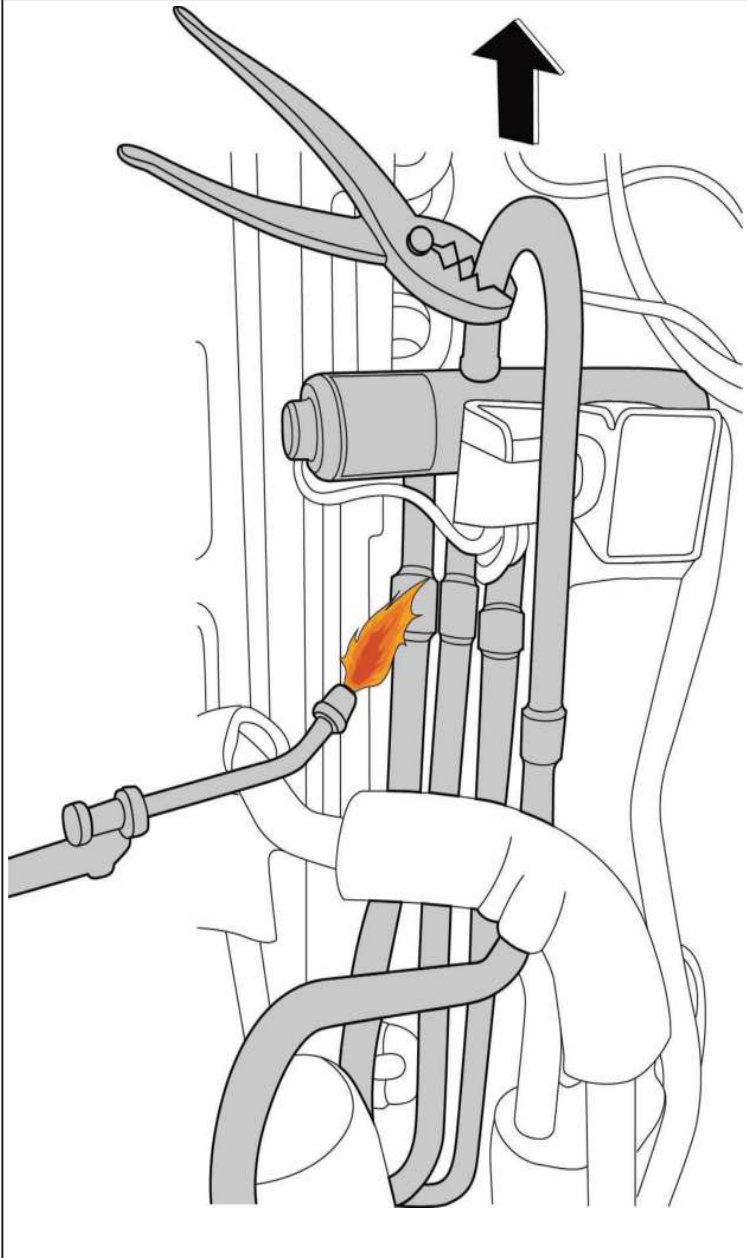
Procedure	Illustration
<ol style="list-style-type: none">1) Heat up the brazed parts and then detach the 4-way valve and the pipe.2) Remove the 4-way valve assembly with pliers.	

Compressor



WARNING

Evacuate the system and confirm that there is no refrigerant left in the system before removing the four-way valve and the compressor. (For R32 & R290, you should evacuate the system with the vacuum pump; flush the system with nitrogen; then repeat the two steps before heating up the brazed parts. The operation should be performed by an authorized technician.

NOTE: Remove the panel plate and PCB compressor connection before disassembling sound blanket.

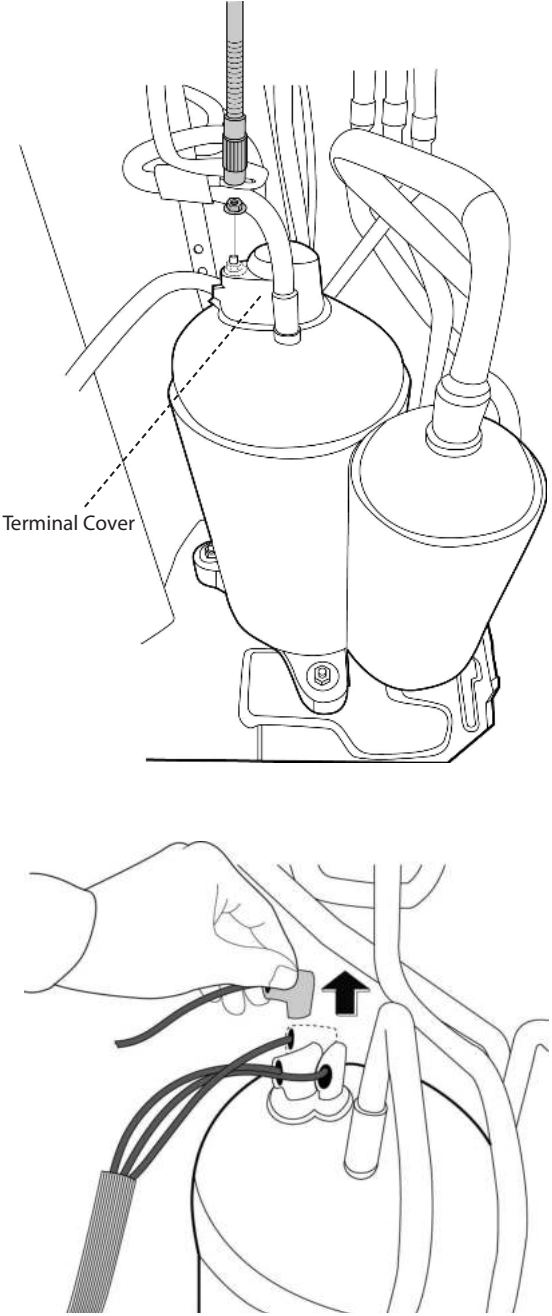
Procedure	Illustration
<p>1) Remove the terminal cover's flange nut and remove the terminal cover.</p> <p>2) Disconnect the connectors.</p>	

Procedure

Illustration

3) Remove the hex nuts and washers securing the compressor, located on the bottom plate.

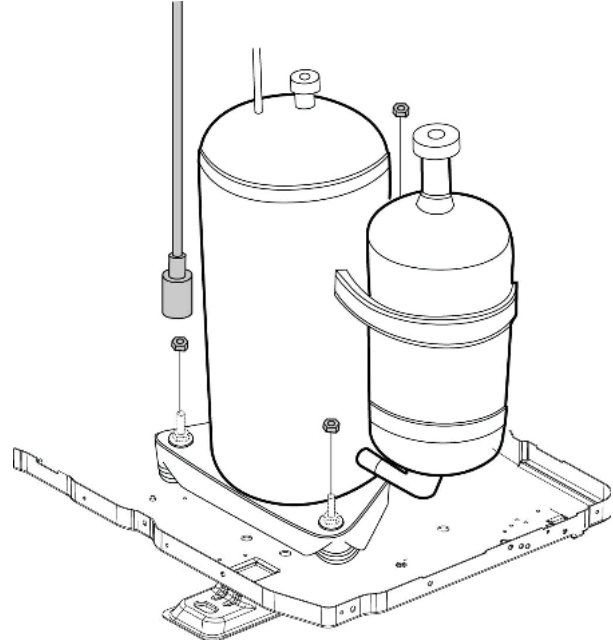

4) Heat up the brazed parts and then remove the discharge pipe and the suction pipe.

5) Lift the compressor from the base pan assembly with pliers.

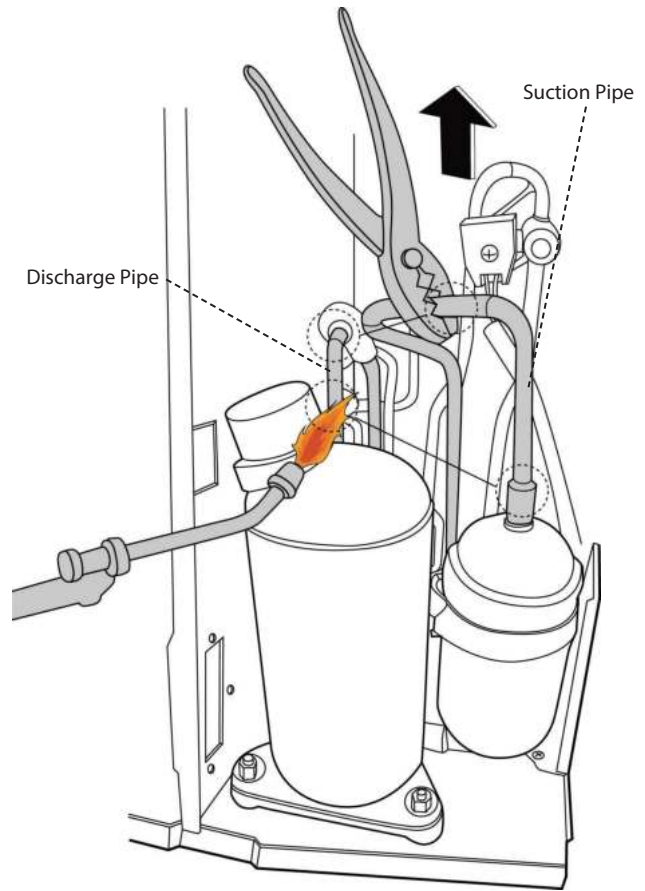

SAFETY CAUTION



WARNING

Be sure to turn off all the power supplies or disconnect all wires to avoid electric shock.

While checking the indoor or outdoor PCB, equip yourself with anti-static gloves or a wrist strap to avoid damage to the board.



WARNING

Electricity remains in the capacitors even when the power supply is off.

Ensure the capacitors are fully discharged before troubleshooting.

Test the voltage between P and N on the back of the main PCB with a multimeter. If the voltage is lower than 36V, the capacitors are fully discharged.

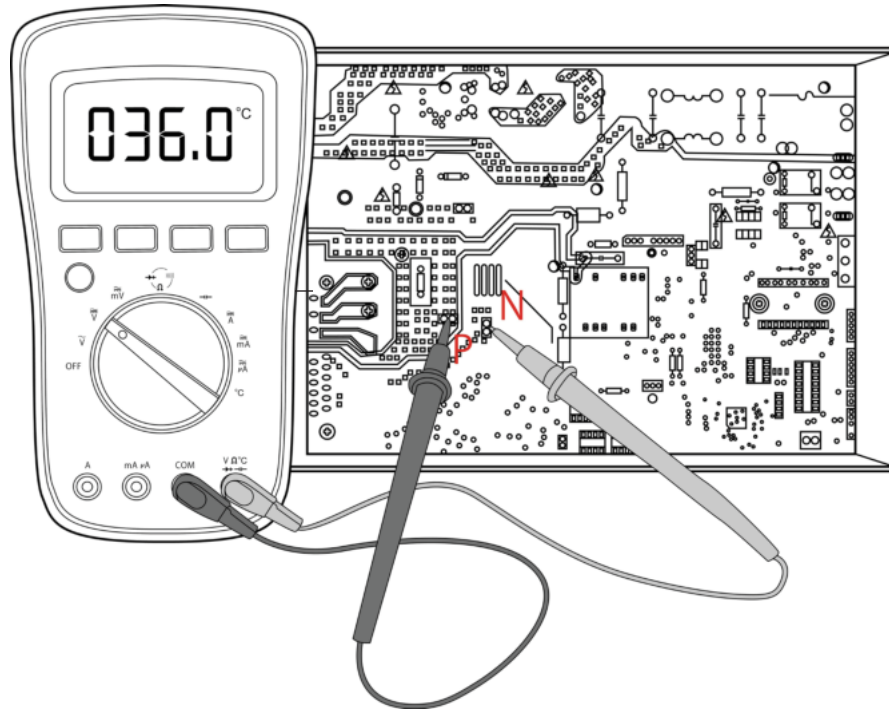

Fig. 50 —Testing

Appendix 1

Table 26 — Temperature Sensor Resistance Value Table for T1, T2, T3, T4 (°C--K)

°C	°F	K Ohm	°C	°F	K Ohm	°C	°F	K Ohm	°C	°F	K Ohm
-20	-4	115.266	20	68	12.6431	60	140	2.35774	100	212	0.62973
-19	-2	108.146	21	70	12.0561	61	142	2.27249	101	214	0.61148
-18	0	101.517	22	72	11.5	62	144	2.19073	102	216	0.59386
-17	1	96.3423	23	73	10.9731	63	145	2.11241	103	217	0.57683
-16	3	89.5865	24	75	10.4736	64	147	2.03732	104	219	0.56038
-15	5	84.219	25	77	10	65	149	1.96532	105	221	0.54448
-14	7	79.311	26	79	9.55074	66	151	1.89627	106	223	0.52912
-13	9	74.536	27	81	9.12445	67	153	1.83003	107	225	0.51426
-12	10	70.1698	28	82	8.71983	68	154	1.76647	108	226	0.49989
-11	12	66.0898	29	84	8.33566	69	156	1.70547	109	228	0.486
-10	14	62.2756	30	86	7.97078	70	158	1.64691	110	230	0.47256
-9	16	58.7079	31	88	7.62411	71	160	1.59068	111	232	0.45957
-8	18	56.3694	32	90	7.29464	72	162	1.53668	112	234	0.44699
-7	19	52.2438	33	91	6.98142	73	163	1.48481	113	235	0.43482
-6	21	49.3161	34	93	6.68355	74	165	1.43498	114	237	0.42304
-5	23	46.5725	35	95	6.40021	75	167	1.38703	115	239	0.41164
-4	25	44	36	97	6.13059	76	169	1.34105	116	241	0.4006
-3	27	41.5878	37	99	5.87359	77	171	1.29078	117	243	0.38991
-2	28	39.8239	38	100	5.62961	78	172	1.25423	118	244	0.37956
-1	30	37.1988	39	102	5.39689	79	174	1.2133	119	246	0.36954
0	32	35.2024	40	104	5.17519	80	176	1.17393	120	248	0.35982
1	34	33.3269	41	106	4.96392	81	178	1.13604	121	250	0.35042
2	36	31.5635	42	108	4.76253	82	180	1.09958	122	252	0.3413
3	37	29.9058	43	109	4.5705	83	181	1.06448	123	253	0.33246
4	39	28.3459	44	111	4.38736	84	183	1.03069	124	255	0.3239
5	41	26.8778	45	113	4.21263	85	185	0.99815	125	257	0.31559
6	43	25.4954	46	115	4.04589	86	187	0.96681	126	259	0.30754
7	45	24.1932	47	117	3.88673	87	189	0.93662	127	261	0.29974
8	46	22.5662	48	118	3.73476	88	190	0.90753	128	262	0.29216
9	48	21.8094	49	120	3.58962	89	192	0.8795	129	264	0.28482
10	50	20.7184	50	122	3.45097	90	194	0.85248	130	266	0.2777
11	52	19.6891	51	124	3.31847	91	196	0.82643	131	268	0.27078
12	54	18.7177	52	126	3.19183	92	198	0.80132	132	270	0.26408
13	55	17.8005	53	127	3.07075	93	199	0.77709	133	271	0.25757
14	57	16.9341	54	129	2.95896	94	201	0.75373	134	273	0.25125
15	59	16.1156	55	131	2.84421	95	203	0.73119	135	275	0.24512
16	61	15.3418	56	133	2.73823	96	205	0.70944	136	277	0.23916
17	63	14.6181	57	135	2.63682	97	207	0.68844	137	279	0.23338
18	64	13.918	58	136	2.53973	98	208	0.66818	138	280	0.22776
19	66	13.2631	59	138	2.44677	99	210	0.64862	139	282	0.22231

Appendix 2

Table 27 — Temperature Sensor Resistance Value Table for T5 (° C- -K)

°C	°F	K Ohm	°C	°F	K Ohm	°C	°F	K Ohm	°C	°F	K Ohm
-20	-4	542.7	20	68	68.66	60	140	13.59	100	212	3.702
-19	-2	511.9	21	70	65.62	61	142	13.11	101	214	3.595
-18	0	483	22	72	62.73	62	144	12.65	102	216	3.492
-17	1	455.9	23	73	59.98	63	145	12.21	103	217	3.392
-16	3	430.5	24	75	57.37	64	147	11.79	104	219	3.296
-15	5	406.7	25	77	54.89	65	149	11.38	105	221	3.203
-14	7	384.3	26	79	52.53	66	151	10.99	106	223	3.113
-13	9	363.3	27	81	50.28	67	153	10.61	107	225	3.025
-12	10	343.6	28	82	48.14	68	154	10.25	108	226	2.941
-11	12	325.1	29	84	46.11	69	156	9.902	109	228	2.86
-10	14	307.7	30	86	44.17	70	158	9.569	110	230	2.781
-9	16	291.3	31	88	42.33	71	160	9.248	111	232	2.704
-8	18	275.9	32	90	40.57	72	162	8.94	112	234	2.63
-7	19	261.4	33	91	38.89	73	163	8.643	113	235	2.559
-6	21	247.8	34	93	37.3	74	165	8.358	114	237	2.489
-5	23	234.9	35	95	35.78	75	167	8.084	115	239	2.422
-4	25	222.8	36	97	34.32	76	169	7.82	116	241	2.357
-3	27	211.4	37	99	32.94	77	171	7.566	117	243	2.294
-2	28	200.7	38	100	31.62	78	172	7.321	118	244	2.233
-1	30	190.5	39	102	30.36	79	174	7.086	119	246	2.174
0	32	180.9	40	104	29.15	80	176	6.859	120	248	2.117
1	34	171.9	41	106	28	81	178	6.641	121	250	2.061
2	36	163.3	42	108	26.9	82	180	6.43	122	252	2.007
3	37	155.2	43	109	25.86	83	181	6.228	123	253	1.955
4	39	147.6	44	111	24.85	84	183	6.033	124	255	1.905
5	41	140.4	45	113	23.89	85	185	5.844	125	257	1.856
6	43	133.5	46	115	22.89	86	187	5.663	126	259	1.808
7	45	127.1	47	117	22.1	87	189	5.488	127	261	1.762
8	46	121	48	118	21.26	88	190	5.32	128	262	1.717
9	48	115.2	49	120	20.46	89	192	5.157	129	264	1.674
10	50	109.8	50	122	19.69	90	194	5	130	266	1.632
11	52	104.6	51	124	18.96	91	196	4.849			
12	54	99.69	52	126	18.26	92	198	4.703			
13	55	95.05	53	127	17.58	93	199	4.562			
14	57	90.66	54	129	16.94	94	201	4.426			
15	59	86.49	55	131	16.32	95	203	4.294			
16	61	82.54	56	133	15.73	96	205	4.167			
17	63	78.79	57	135	15.16	97	207	4.045			
18	64	75.24	58	136	14.62	98	208	3.927			
19	66	71.86	59	138	14.09	99	210	3.812			

Appendix 3

Table 28 — Appendix 3

°C	°F	°C	°F	°C	°F	°C	°F	°C	°F
-5	23	21	69.8	51	123.8	82	179.6	113	235.4
-4	24.8	22	71.6	52	125.6	83	181.4	114	237.2
-3	26.6	23	73.4	53	127.4	84	183.2	115	239
-2	28.4	24	75.2	54	129.2	85	185	116	240.8
-1	30.2	25	77	55	131	86	186.8	117	242.6
0	32	25.5	77.9	56	132.8	87	188.6	118	244.4
0.5	32.9	26	78.8	57	134.6	88	190.4	119	246.2
1	33.8	27	80.6	58	136.4	89	192.2	120	248
1.5	34.7	28	82.4	59	138.2	90	194	121	249.8
2	35.6	29	84.2	60	140	91	195.8	122	251.6
2.5	36.5	30	86	61	141.8	92	197.6	123	253.4
3	37.4	31	87.8	62	143.6	93	199.4	124	255.2
3.5	38.3	32	89.6	63	145.4	94	201.2	125	257
4	39.2	33	91.4	64	147.2	95	203	126	258.8
4.5	40.1	34	93.2	65	149	96	204.8	127	260.6
5	41	35	95	66	150.8	97	206.6	128	262.4
6	42.8	36	96.8	67	152.6	98	208.4	129	264.2
7	44.6	37	98.6	68	154.4	99	210.2	130	266
8	46.4	38	100.4	69	156.2	100	212	131	267.8
9	48.2	39	102.2	70	158	101	213.8	132	269.6
10	50	40	104	71	159.8	102	215.6	133	271.4
11	51.8	41	105.8	72	161.6	103	217.4	134	273.2
12	53.6	42	107.6	73	163.4	104	219.2	135	275
13	55.4	43	109.4	74	165.2	105	221	136	276.8
14	57.2	44	111.2	75	167	106	222.8	137	278.6
15	59	45	113	76	168.8	107	224.6	138	280.4
16	60.8	46	114.8	77	170.6	108	226.4	139	282.2
17	62.6	47	116.6	78	172.4	109	228.2	140	284
18	64.4	48	118.4	79	174.2	110	230	141	285.8
19	66.2	49	120.2	80	176	111	231.8	142	287.6
20	68	50	122	81	177.8	112	233.6	143	289.4