

SUBMITTAL DATA SHEET	OS-EL12ALP115VI	OS-EL12ALP115VO
----------------------	-----------------	-----------------

Job Name: Date:
 Location: Approval:
 Engineer: Construction:
 Submitted to: Unit #:
 Submitted by: Drawing #:
 Reference:



OUTDOOR SPECIFICATION

Air flow	1059 CFM
Noise Level	55 dB(A)
Dimension (WxDxH)	30.31x11.81x21.85 in
Net/Gross weight	55.11/58.86 lb
Refrigerant type/Quantity	R410A/25.75 oz
Refrigerant precharge	25 ft
Additional charge for each ft	0.16 oz

PERFORMANCE AND EFFICIENCY

Cooling		Heating	
12,000 Btu/h		12,000 Btu/h	
SEER	16.5	HSPF4/ HSPF5	9.4/7.7
EER	8.8	COP	2.9

OPERATION TEMPERATURE RANGE

Indoor		Outdoor	
cooling	heating	cooling	heating
62~90°F	32~86°F	5~122°F	5~86°F

ELECTRICAL

Power supply	208-230V/60Hz, 1Ph
MCA	17 A
MFA	20 A

MCA: Minimum Circuit Ampacity

MFA: Max. fuse A

PIPING

Refrigerant piping Liquid side/Gas side	1/4 - 3/8 in
Max. refrigerant pipe length	82 ft
Max. difference in level	33 ft

The warranty is valid only in case it is registered within 60 days after purchase date on our website www.olmo-comfort.com. The warranty is only valid when installed by a Licensed HVAC Technician. A warranty period of Five (5) years on compressor to the original registered end-user. A warranty period of Two (2) years on all parts to the original registered end user. A warranty period of One (1) year on the remote control provided with the original unit.



GENERAL FEATURES

- Auto Swing
- Intelligent Pre-heating
- Comfortable Sleep Mode
- Inverter Technology
- Auto Restart Function
- LED Display
- Timer
- Automatic Operation
- Dry Anti-mildew Design
- Self-diagnosis
- Fan Delay Function
- Multiple Fan Speeds

INDOOR SPECIFICATION

Air Flow (Hi/Mi/Lo)	318/241/177 CFM
Noise Level (Hi/Mi/Lo)	41/34.5/27.5 dB(A)
Unit Dimension (WxDxH)	31.69x7.64x11.22 in
Net/Gross Weight	17.20/22.27 lb

SUBMITTAL DATA SHEET

OS-EL12ALP115VI

OS-EL12ALP115VO

INDOOR UNIT

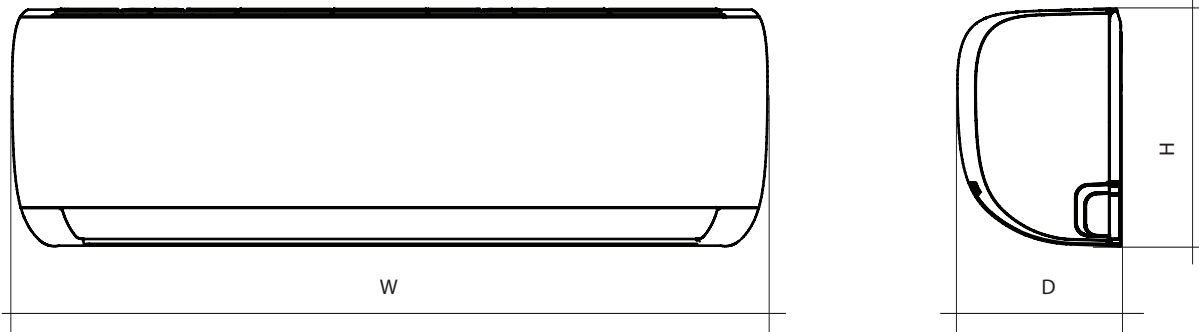

Indoor Unit Dimensions, in		
W	D	H
31.69	7.64	11.22

OUTDOOR UNIT

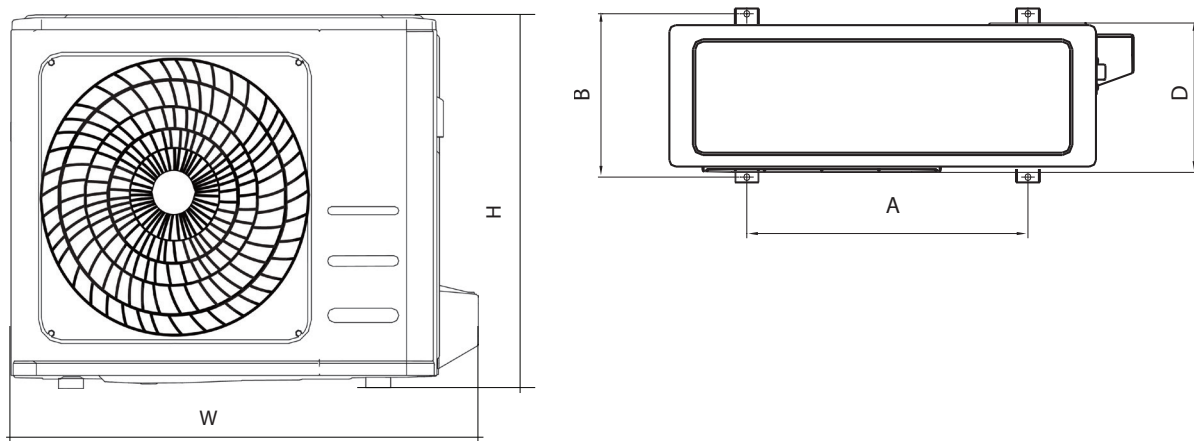

Outdoor Unit Dimensions WxDxH	Mounting Dimensions	
	Distance A	Distance B
30.31x11.81x21.85	17.8	10.08